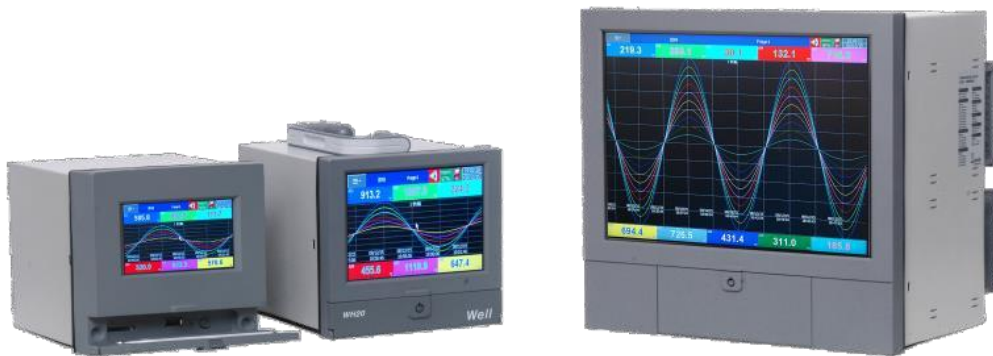


**Well**<sup>®</sup>

# WH10-20-30 Series

## Touch Paperless Recorder



## User Manual

# TABLE OF CONTENTS

<b>1. GENERAL DESCRIPTION .....</b>	<b>8</b>
1.1 UNIQUE FEATURES OF RECORDER.....	8
1.2 COMPARISON OF WH SERIES RECORDERS.....	11
1.3 EXPANDABLE INPUT AND OUTPUT CARDS.....	12
1.4 COMMUNICATION .....	14
1.5 EXTERNAL STORAGE MEDIA .....	14
1.6 SMART MECHANISM .....	15
1.7 ORDERING CODES AND ACCESSORIES.....	16
1.7.1 WH10 Ordering code .....	16
1.7.2 WH 20 Ordering code .....	18
1.7.3 WH 30 Ordering code .....	20
1.7.4 Accessories.....	22
1.8 SPECIFICATIONS.....	23
<b>2. INSTALLATION AND WIRING.....</b>	<b>28</b>
2.1 UNPACKING.....	28
2.2 INSTALLATION.....	28
2.3 PANEL MOUNTING STYLE .....	29
2.4 SETUP INPUT AND OUTPUT .....	35
2.5 WIRING OF THE CARDS .....	40
2.6 RS-232, RS-422, RS-485 WIRING.....	47
2.7 EXTERNAL MEMORY CARD .....	48
<b>3. BASIC FUNCTIONS OF RECORDERS.....</b>	<b>50</b>
3.1 CONFIGURATION .....	50
3.2 STANDARD AND PLUS VERSION OF FIRMWARE.....	50
3.3 COMMUNICATION WITH THIRD PARTY INTERFACES.....	52
3.4 INFORMATION ACCESEBILITY THROUGH WEB .....	52
3.5 HANDWRITING MESSAGES ON TREND SCREENS.....	53
3.6 CUSTOM EDITTED DISPLAY SCREENS.....	57
3.7 ANALOG INPUT LOG SPEED FLEXIBILITY .....	58
3.8 HIGH SPEED INPUT .....	58
3.9 SYSTEM CLOCK SYNCHRONIZATION VIA INTERNET.....	58
3.10 INCREASED SECURITY IN PASSWORD CONFIGURATION .....	58
3.11 AUTO OUTPUT TO WHINTER.....	58
3.12 EXTERNAL CHANNELS .....	58

3.13	BATCH .....	58
3.14	FDA 21 CFR PART 11 .....	58
<b>4.</b>	<b>CONFIGURATION .....</b>	<b>59</b>
4.1	CHANNEL.....	60
4.1.1	Analog Input .....	60
4.1.2	Digital Input .....	67
4.1.3	Math Channel.....	69
4.1.4	Analog Output .....	83
4.1.5	Digital Output .....	84
4.1.6	External .....	84
4.1.7	Jobs.....	85
4.2	DISPLAY.....	88
4.2.1	Status Bar .....	90
4.3	TIMER .....	91
4.4	CLOCK .....	94
4.5	COMMUNICATION .....	95
4.5.1	Connections .....	98
4.5.2	Commands.....	99
4.5.3	Modbus RTU Master , Example1 .....	100
4.5.4	Modbus RTU Master , Example2.....	103
4.5.5	Modbus RTU Slave , Example .....	105
4.6	INSTRUMENT .....	107
4.7	SECURITY .....	108
4.7.1	Normal.....	108
4.7.2	CFR-21.....	109
4.8	DEMO .....	110
4.9	AUTO-OUTPUT .....	110
4.9.1	USB WHinter.....	111
4.9.2	Network WHinter (LPT1).....	113
4.9.3	WHint Historical data .....	115
4.9.4	WHint Reports.....	116
4.9.5	WHint Snapshot .....	117
4.10	SYSTEM INFO.....	118
4.11	BATCH CONTROL.....	122
4.12	CALIBRATE .....	130
<b>5.</b>	<b>PC BASED SOFTWARE.....</b>	<b>134</b>
5.1	FREE BASIC SOFTWARE.....	134
5.1.1	Requirements.....	134

5.1.2	Operating system .....	134
5.1.3	Software .....	134
5.1.4	Ethernet Configuration .....	138
<b>5.2</b>	<b>DATA ACQUISITION STUDIO SOFTWARE.....</b>	<b>141</b>
5.2.1	Requirements.....	142
5.2.2	Operating system .....	142
5.2.3	Software .....	142
5.2.4	How to configure Communication Bank.....	142
5.2.5	How to configure Recorder .....	146
5.2.6	Touch Screen.....	146
5.2.7	Ethernet.....	146
5.2.8	Removable Media .....	150
5.2.9	Configuration.....	154
5.2.10	How to view Historical data .....	165
5.2.11	How to view Real time data in PC.....	172
5.2.12	Bank configuration .....	173
5.2.13	Ethernet.....	175
5.2.14	Serial (RS232/422/485) .....	178
5.2.15	View Real time data from Multiple Recorders.....	178
<b>5.3</b>	<b>PANEL STUDIO VERSION.....</b>	<b>179</b>
5.3.1	System Requirements.....	180
5.3.2	Software Installation.....	181
5.3.3	WHOject status .....	182
5.3.4	Create new WHOject .....	183
5.3.5	Menu bar .....	184
5.3.6	File .....	185
5.3.7	Environment.....	186
5.3.8	Edit.....	188
5.3.9	Format.....	189
5.3.10	View .....	191
5.3.11	Objects.....	193
5.3.12	WHOject.....	195
5.3.13	Standard bar .....	195
5.3.14	Format bar.....	196
5.3.15	WHOject Explorer .....	197
5.3.16	Screen.....	197
5.3.17	Tool box .....	201
5.3.18	Enhanced Objects.....	260
5.3.19	Graphics.....	288
5.3.20	Symbol Factory .....	296

5.3.21	WHOject Tools.....	307
5.3.22	Build .....	307
5.3.23	Build & Offline Simulation .....	308
5.3.24	Stop.....	309
5.3.25	Build & Download.....	309
5.3.26	Download .....	309
5.3.27	WHOject status .....	311
<b>6.</b>	<b>WEBSERVER.....</b>	<b>312</b>
<b>6.1</b>	<b>REQUIREMENTS.....</b>	<b>312</b>
6.1.1	Hardware.....	312
6.1.2	Operating system .....	312
6.1.3	Browser Requirements .....	312
6.1.4	IP Address Requirements .....	313
<b>6.2</b>	<b>HOW TO CONFIGURE WEB SERVER SETTINGS.....</b>	<b>313</b>
6.2.1	How to Configure Static IP Address.....	314
6.2.2	How to Enable Web Server.....	315
<b>6.3</b>	<b>HOW TO VIEW RECORDER DATA IN PC VIA WEBSERVER.....</b>	<b>316</b>

## Safety

This recorder is compliant with the requirements of EN61010-1, UL 61010C-1 & CSA C22.2 No. 24-93. The WHotective WHovided by the recorder may be impaired if it is used in a manner inconsistent with its intended purpose, or in an environment that exceeds the specifications of the recorder. Brainchild Electronic Co., Ltd. is not liable for customer's failure to comply with these requirements.

## Safety Symbols

The following symbols may be seen on the user manual or recorder labeling.



**Caution**



**WHotective Earth**



**DC Supply**

## Safety Notes and WHecaution

1. The WHotective earth terminal should be connected first before any other connection is made. To avoid making the recorder dangerous under fault conditions, any interruption of the WHotective Earth conductor inside or outside the recorder is WHohibited. Even in the case of a portable unit, the WHotective earth terminal must remain connected if the recorder is connected to any hazardous voltage.
2. Keep signal and supply voltage wiring separated from one another. If this is imWHactical, use shielded cables for signal wiring. Double insulation should be used for signal wiring when the recorder is being used with hazardous voltage.
3. Do not use the recorder where there is high vibration, or high magnetic field, this could cause damage or error of measurement.
4. All maintenance or repairs should be carried out with power disconnected, to avoid personal injury, or damage to the unit.

5. In areas with conductive pollution, adequate ventilation, filtering and sealing need to be installed.
6. When cleaning the recorder, handle carefully and use soft dry cloth. Avoid the use of abrasives or any sharp and hard objects, which would damage the display.
7. Do not operate the recorder if any part has been removed or disassembled. Consult your nearest dealer at once.

### **Static Electricity**

Appropriate precautions must be taken when handling the recorder. The circuit board, components are susceptible to damage caused by electrostatic discharge. Take static electricity precautions whilst handling and inserting USB memory into the recorder.

# 1. General Description

## 1.1 Unique features of recorder

The WH series is a well-designed new generation paperless recorders with many outstanding features as follows:

### **Hardware**

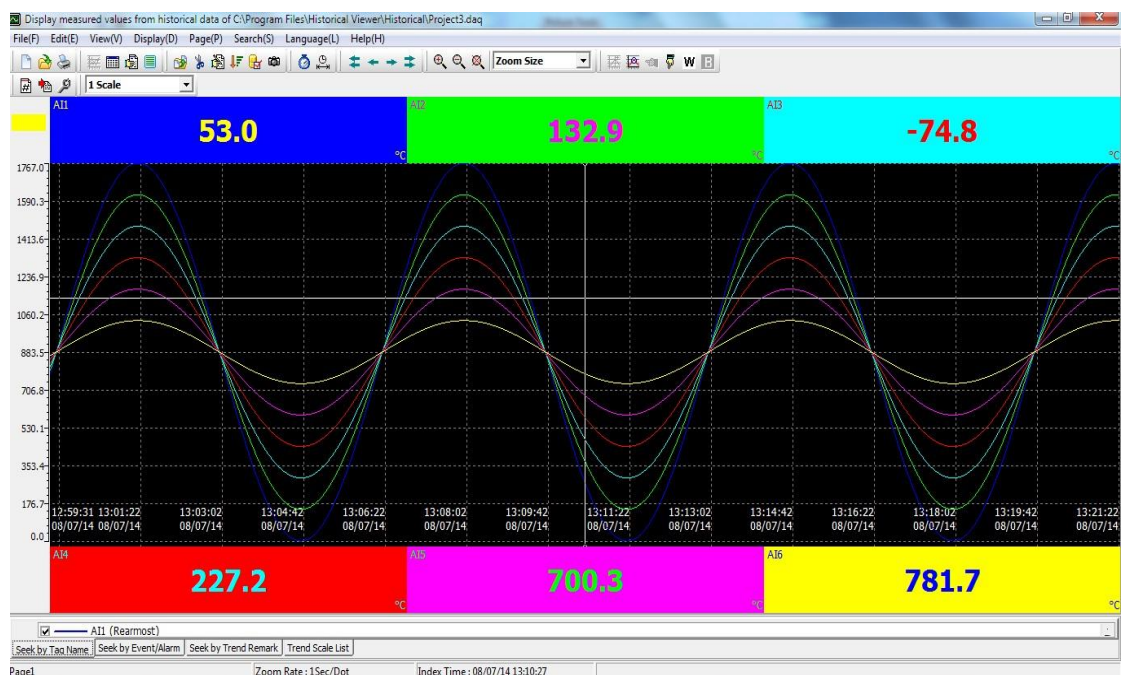
- Three sizes of 4.3", 5.6" and 12.1"
- WH10, with 4.3" display, fixed 6 universal analog inputs
- WH20, with 5.6" display, 6, 12, 18 up to 24 universal analog inputs
- WH30, with 12.1" display, 6, 12, 18, 24, 30, 36, 42 up to 48 universal analog inputs
- TFT Color LCD, Touch screen & high resolution
- 100 milli second sample rate and data logging
- High accuracy 24-bit A-D Analog Input
- 16-bit D-A Analog Output
- Digital input, maximum 100 Hz.
- Plug & play I/O cards (AI, AO, DI, DO) for easy expansion
- On board SD card for Internal memory
- External solid storage media USB flash memory in high capacity
- 171 mm short depth
- Ethernet as standard and optional RS-232/422/485 communication
- Two USB Host ports for downloading the data or connect to WHinter
- IP65 / NEMA 4X water-resistance



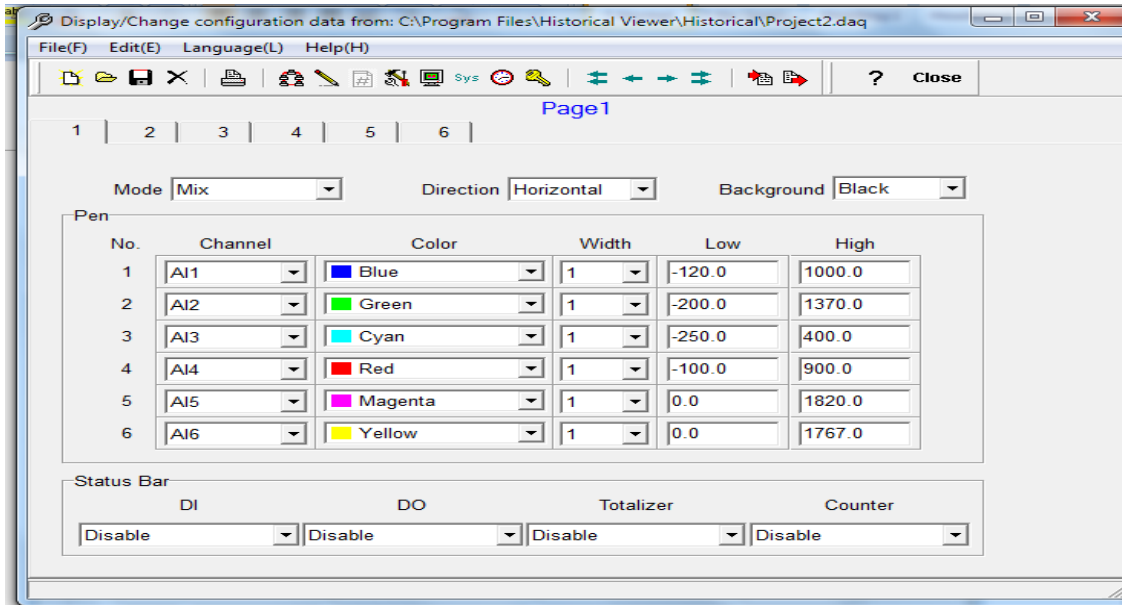
## ***Firmware and PC Software***

- Free Basic software for configuration, Historical viewer
- Extensive Software ,Data Acquisition Software for configuration, Historical viewer and Real time viewer
- Additional Panel Studio Software for editing customized Displays
- Display values in Digital, Real time trends, Historical trends, Bar graphs etc
- Real time and Historical alarms
- Event management, Jobs linked with events
- Reports (Daily, Weekly and Monthly)
- Timers, Optional -Counters, Totalizers, Math channels and CFR-21
- Customized messages for the alarms
- Alarms by email directly from paperless recorder
- Batch control, log data in batches
- 100 msec. data logging and historical data archival tools
- Display screens rotation
- Data dynamic exchange feature via PC software
- Search data with reference to time and period and Export to sWHead sheets
- Data logging by value change or time base
- Start/Stop data logging functions which can be linked with real time clock or events

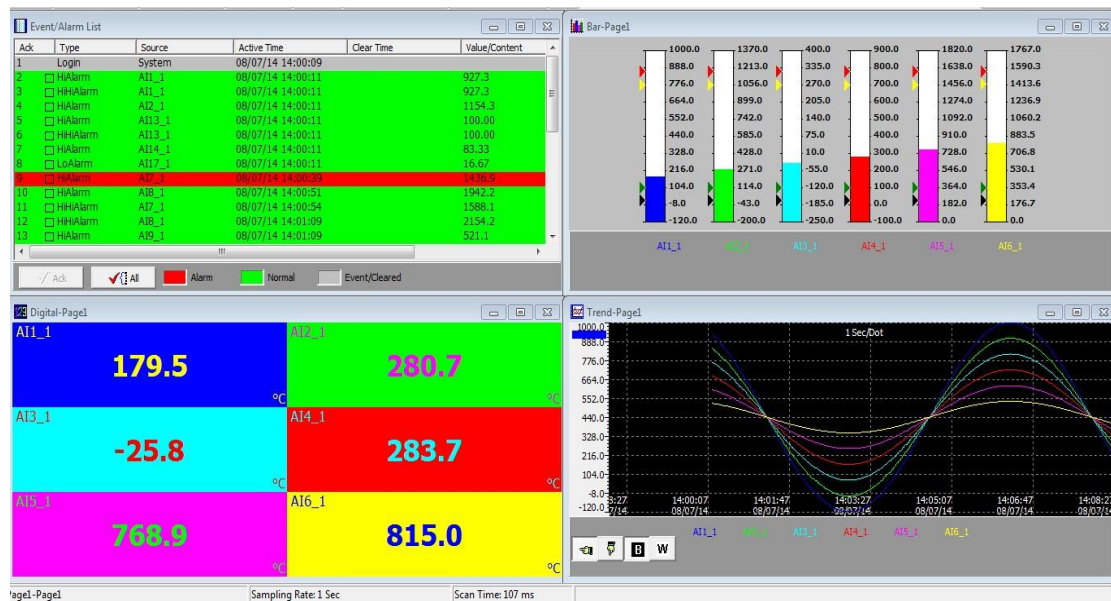
Historical Viewer in Free and Extensive Software:



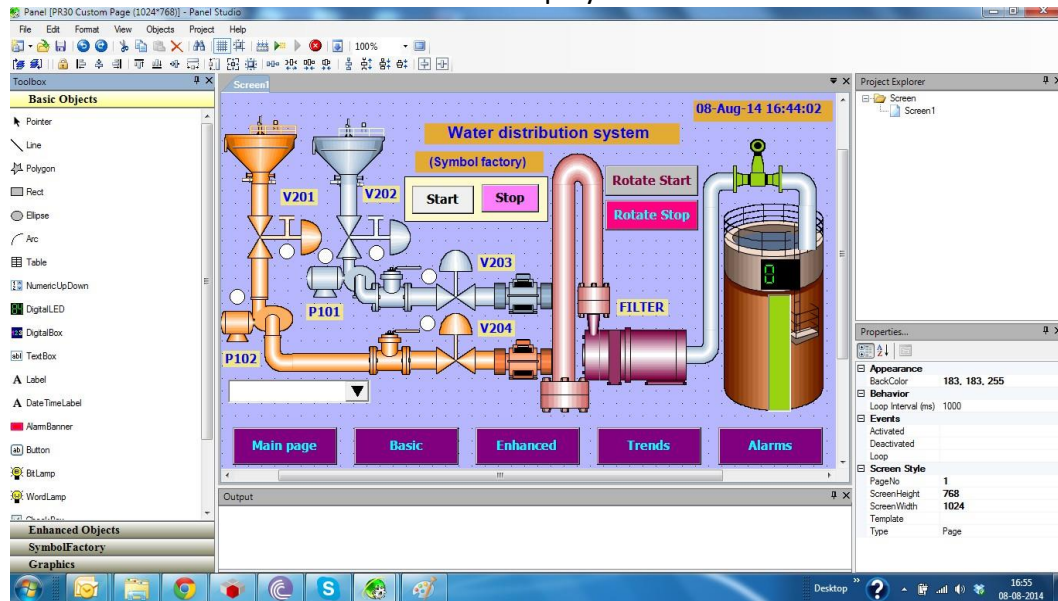
Editing Configuration in Free and Extensive Software:



Extensive Software Data Acquisition Studio with Real-time Viewer:



## Panel Studio Software to Edit Custom Displays:



### 1.2 Comparison of WH series Recorders

Description	WH10	WH20	WH30
<b>Display Size</b>	<b>4.3"</b>	<b>5.6"</b>	<b>12.1"</b>
<b>Analog Inputs (Maximum)</b>	<b>6</b>	<b>24</b>	<b>48</b>
<b>Math Channels (Maximum)</b>	<b>15</b>	<b>40</b>	<b>60</b>
<b>External Channels (Other devices)</b>	<b>24</b>	<b>48</b>	<b>96</b>
<b>Total Pages</b>	<b>8</b>	<b>20</b>	<b>21</b>
<b>Pens/Page (Maximum)</b>	<b>6</b>	<b>6</b>	<b>10</b>
<b>Batches (Maximum)</b>	<b>1</b>	<b>1</b>	<b>1</b>

### 1.3 Expandable Input and Output cards

The recorder is equipped with rear expansion slots, which work flexibly with the following plug & play I/O cards.

**Analog Input cards** (part number AI206 & AI203): These two cards are used for 6 & 3-channel analog input. Each input is isolated from each other to avoid noise and to ensure stable measurement.

**AI206**  
6 AI (6 analog inputs)



**AI203**  
3 AI (3 analog inputs)



**Relay Output card** (RO206): Each card includes 6 alarm relays. Contacts are rated 5 Amp/240 VAC

**RO206**  
6 relay outputs



**Digital Input card (DI206):** Each card includes 6 channels. Logic Low: -5V minimum, 0.8V maximum, Logic High: 3.5V minimum, 24V maximum

**DI206**  
**6 DI (6 digital inputs)**



**Relay Output and Digital Input Card (RD233):** Each Card includes 3-digital Inputs and 3-Relay Outputs. For Digital Inputs , Logic Low: -5V minimum, 0.8V maximum, Logic High: -3.5V minimum, 24V maximum. For Relay Outputs , the Contacts are rated 5 Amp/240 VAC

**RD233**  
**3 relays + 3DI**



**Analog Output cards (AO206):** Each card includes 6 channels. They are used for 4-20mA, 0-20mA current output, 0-5V, 1-5V, 0-10VDC voltage output.

**AO206**  
**6 AO (6 analog outputs)**



**Note1 :** The IO Cards should not be removed or Inserted to the WH when the Power is ON. This should be carried out at Power OFF Condition only.

**Note2 :** For Thermocouple Inputs , 1 hour inputs warm up is necessary for first initial set up .

## 1.4 Communication

The standard communication interface is Ethernet with WHotocol IEEE 802.3 – 10/100 BaseT. other options are RS-232 / RS-422 / RS-485.

## 1.5 External Storage media

We have got two types External storage Media, SD card and USB for the recorder. If the recorder is used with **6-channel inputs**, an easy chart to show the maximum days

	SD card	16GB	32GB
Log speed			
1 second		15808 days	31616 days
10 seconds		158032 days	316064 days
120 seconds		1896304 days	3792608 days

\* The above is an apWHoximation  
Each record of data uses 2 bytes or 4 bytes of memory.

For ex: Selected data size = 2 bytes

If the Log Speed ( the recording speed of measured data ) is set to the fastest speed at 1 second per data, then for a six channels, 16GB SD Card will last apWHoximately 15808 days [= 16GB / ( 2 bytes x 24 hours x 60 minutes x 60 seconds x 6 Channels )].

**The following formula** is to calculate how many days the USB disk could do saving before it is full.

***The ? days = (The capacity of SD card memory x Log Speed) / ( 2 x no. of hours per day x 60 x 60 x Number of channels )***

***If the User is using USB to store data, To avoid losing recorded data while transferring to PC, it is necessary to insert USB memory back again into the recorder soon after loading recorded data onto PC.***

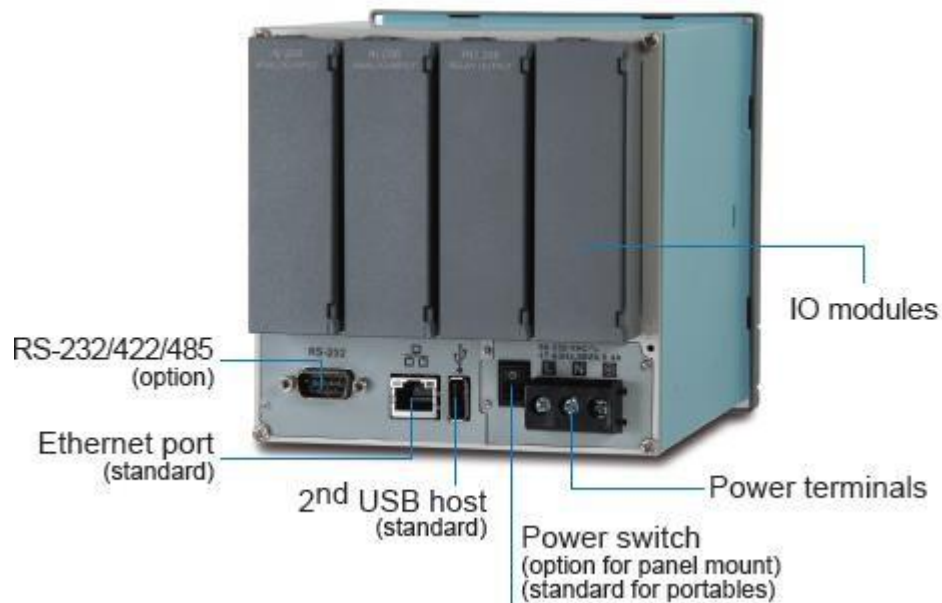
## 1.6 Smart Mechanism

The recorded data is stored in the manufacturer's special binary format. It is not possible to manipulate or modify the recorded data. This feature fully guarantees the security of the data.

Front View:



Rear View:





4: portable,SAA power cord , power switch

5: portable,BS power cord , power switch

6: portable,GB power cord , power switch

### **7&8 Special options**

00: none

01: 16G SD card

02: 32G SD card

\*DI- Digital Input

## 1.7.2 WH 20 Ordering code

**WH2003 ( 3 Analog Inputs)** - □ □ □ □ □ □ □ □  
1 2 3 4 5 6 7 8

### 1 Other Inputs and Outputs\*

0: none

6: 3 relays + 3 DI

C: 3 relays + 3 DI + 6 AO

### WH2006 ( 6 Analog Inputs)

### 1 Other Inputs and Outputs\*

0: none

1: 6 Relays

3: 6 DI

5: 6 AO

6: 3 relays + 3 DI

7: 6 relays + 6 DI

A: 6 relays + 6 AO

B: 6 DI + 6 AO

C: 3 relays + 3 DI + 6 AO

D: 6 relays + 6 DI + 6 AO

### WH2012 ( 12 Analog Inputs)

### 1 Other Inputs and Outputs\*

0: none

1: 6 Relays

2: 12 Relays

3: 6 DI

4: 12 DI

5: 6 AO

6: 3 relays + 3 DI

7: 6 relays + 6 DI

A: 6 relays + 6 AO

B: 6 DI + 6 AO

C: 3 relays + 3 DI + 6 AO

### WH2018 ( 18 Analog Inputs)

### 1 Other Inputs and Outputs\*

0: none

1: 6 Relays

3: 6 DI

5: 6 AO

6: 3 relays + 3 DI

## WH2024 ( 24 Analog Inputs)

### 1 Other Inputs and Outputs\*

0: none

### 2 Power

A: 90-250 VAC, 50/60 Hz

D: 11-36 VDC

### 3 Communication

0: standard Ethernet interface

1: Ethernet + RS-232

2: Ethernet + RS-422/485

### 4 Firmware

0: Standard Version

1: Plus Version 1 with extra mathematics, external channels, batch & FDA21 CFR part 11

2: Plus Version 2 with editable custom display and software Panel Studio to be supplied.

3: Plus Version 3 including Plus version 1+2 above

### 5 PC Software

1: Free Basic Software of Historical Viewer and Configuration

2: Extensive software Data Acquisition Studio  
( Real Time Viewer + Historical Viewer + Configuration)

### 6 Mounting types, Power Cord & Switch

0: panel mount , no power cord , no power switch

1: panel mount , no power cord , power switch

2: portable, UL & CSA power cord , power switch

3: portable, VDE power cord , power switch

4: portable, SAA power cord , power switch

5: portable, BS power cord , power switch

6: portable, GB power cord , power switch

### 7&8 Special options

00: none

01: 16G SD card

02: 32G SD card

\*DI- Digital Input

AO- Analog Transmission Output

### 1.7.3 WH 30 Ordering code

WH3006 ( 6 Analog Inputs) – □ □ □ □ □ □ □ □ □ □  
1 2 3 4 5 6 7 8 9 10

- WH3012 ( 12 Analog Inputs)
- WH3018 ( 18 Analog Inputs)
- WH3024 ( 24 Analog Inputs)
- WH3030 ( 30 Analog Inputs)
- WH3036 ( 36 Analog Inputs)
- WH3042 ( 42 Analog Inputs)
- WH3048 ( 48 Analog Inputs)

#### 1 Relay Outputs

- 0: none
- 1: 6 Relays
- 2: 12 Relays
- 3: 18 Relays
- 4: 24 Relays

#### 2 Digital Inputs

- 0: none
- 1: 6 Channels
- 2: 12 Channels
- 3: 18 Channels

#### 3 Analog Outputs

- 0: none
- 1: 6 Channels

#### 4 Power

- A: 90-250 VAC, 50/60 Hz
- D: 11-36 VDC

#### 5 Communication

- 0: standard Ethernet interface
- 1: Ethernet + RS-232
- 2: Ethernet + RS-422/485

#### 6 Firmware

- 0: Standard Version
- 1: Plus Version 1 with extra mathematics, external channels, batch & FDA21 CFR part 11
- 2: Plus Version 2 with editable custom display and software Panel Studio to be supplied.
- 3: Plus Version 3 including Plus version 1+2 above

## **7 PC Software**

- 1: Free Basic Software of Historical Viewer and Configuration
- 2: Extensive software Data Acquisition Studio  
( Real Time Viewer + Historical Viewer + Configuration)

## **8 Mounting types, Power Cord & Switch**

- 0: panel mount , no power cord , no power switch
- 1: panel mount , no power cord , power switch
- 2: portable,UL & CSA power cord , power switch
- 3: portable,VDE power cord , power switch
- 4: portable,SAA power cord , power switch
- 5: portable,BS power cord , power switch
- 6: portable,GB power cord , power switch

## **9&10 Special options**

- 00: none
- 01: 16G SD card
- 02: 32G SD card

#### 1.7.4 Accessories:

Part no.	Descriptions
AI203, AI206	3, 6-channel analog input card (TC, RTD, mA, V, mV)
RO206	6-channel relay output card
DI206	6-channel digital input card
RD233	3-channel Relay output and 3-channel digital input card
AO206	6-channel analog output card
IF232	RS-232 communication module
IF485	RS-422/485 communication module
PM201	90-250VAC 47-63Hz panel mount power supply board without power switch for WH10 and WH20
PM202	90-250VAC 47-63Hz panel mount power supply board with power switch for WH10 and WH20
PM203	90-250VAC 47-63Hz portable power supply board with power switch for WH10 and WH20
PM211	11-36VDC panel mount power supply board without power switch for WH10 and WH20
PM212	11-36VDC panel mount power supply board with power switch for WH10 and WH20
PM213	11-36VDC portable power supply board with power switch for WH10 and WH20
PM301	90-250VAC 47-63Hz panel mount power supply board without power switch for WH30
PM302	90-250VAC 47-63Hz panel mount power supply board with power switch for WH30
PM303	90-250VAC 47-63Hz portable power supply board with power switch for WH30
PM311	11-36VDC panel mount power supply board without power switch for WH30
PM312	11-36VDC panel mount power supply board with power switch for WH30
PM313	11-36VDC portable power supply board with power switch for WH30

#### Notes:

- ◆ The rear Slots of the recorder will only accept optional cards of input, output in any combination based on selected model.
- ◆ For example, WH10 shall have 4 empty slots. But only 3 slots can be used . One slot It needs 1 Pc. of either 3 channel or 6 channel analog input card and other slot can be used as per the combination showed in the ordering code.
- ◆ The basic PC software is supplied free together with recorder. There is an additional charge for the extensive Data Acquisition Software supplied with communication of RS-232/422/485 or Ethernet.

- ◆ The Ordering Code of standard model with AC supply without any option for various Recorders are as follows..

WH1003- 0A001000  
WH2003- 0A001000  
WH3006- 000A001000

## 1.8 Specifications

### Power:

#### WH10 and WH20:

90-250VAC, 47-63Hz, 52VA, 26W maximum  
11-36VDC , 26VA, 26W maximum

#### WH30:

90-250VAC, 47-63Hz, 110VA, 62W maximum  
11-36VDC , 62VA, 62W maximum

### Display :

WH10: LCD, 480 x 272 pixel resolution, 65K color  
WH20: LCD, 640 x 480 pixel resolution, 65K color  
WH30: LCD, 1024 x 768 pixel resolution, 65K color

### Memory :

256MB storage memory on board.

### Analog Input Cards (AI20X):

**Channels:** AI203 ~ 3 channels, AI206 ~ 6 channels

**Resolution:** 24 bits

**Sampling Rate:** 10 times/ second

**Maximum Rating:** RTD input  $\pm 20V$

T/C and Voltage input  $\pm 65V$

mA input  $\pm 10V$

**Temperature Effect:**  $\pm 0.1\mu V \pm 15PPM$  of reading for all inputs except mA,  $\pm 30PPM$  of reading for mA input

#### Sensor Lead Resistance Effect:

T/C: 0.32PPM of reading/ohm 3-wire RTD: 2.6 °C /ohm of resistance difference of two leads (Based on °C measurement temperature for PT100)

2-wire RTD: 2.6 °C /ohm of resistance sum of two leads (Based on °C measurement temperature for PT100)

**Burn-out Current:** 10uA

**Common Mode Rejection Ratio (CMRR):** 120dB

**Normal Mode Rejection Ratio (NMRR):** 55dB

**Isolation Breakdown Voltage between channels:** 1500VAC min.

**Sensor Break Detection:**

Sensor opened for TC, RTD and mV inputs, below 1 mA for 4-20mA input, below 0.25V for 1-5V inputs, unavailable for other inputs

Sensor Break Responding Time: Within 1 seconds for TC, RTD and mV inputs, 0.1 second for 4-20 mA and 1-5V inputs

### Characteristics:

Type	Range	Accuracy at 25 °C	Input Impedance
J	-120 ~ 1000 °C (-184 ~ 1832 °F)	±1 °C	3.12MΩ
K	-200 ~ 1370 °C (-328 ~ 2498 °F)	±1 °C °	3.12MΩ
T	-250 ~ 400 °C (-418 ~ 752 °F)	±1 °C	3.12MΩ
E	-100 ~ 900 °C (-148 ~ 1652 °F)	±1 °C	3.12MΩ
B	0 ~ 1820 °C (32 ~ 3308 °F)	±2 °C (200 ~ 1820 °C)	3.12MΩ
R	0 ~ 1768 °C (32 ~ 3214 °F)	±2 °C	3.12MΩ
S	0 ~ 1768 °C (32 ~ 3214 °F)	±2 °C	3.12MΩ
N	-250 ~ 1300 °C (-418 ~ 2372 °F)	±1 °C	3.12MΩ
L	-200 ~ 900 °C (-328 ~ 1652 °F)	±1 °C	3.12MΩ
U	-200 ~ 600 °C (-328 ~ 1112 °F)	±1 °C	3.12MΩ
P	0 ~ 1395 °C (32~2543 °F)	±1 °C	3.12MΩ
W5	0 ~ 2315 °C (32 ~ 4199 °F)	±1 °C	3.12MΩ
W3	0 ~ 2315 °C (32 ~ 4199 °F)	±1 °C	3.12MΩ
LR	-200 ~ 800 °C (-328 ~ 1472 °F)	±1 °C	3.12MΩ
A1	0 ~ 2500 °C (-32 ~ 4532 °F)	±1 °C	3.12MΩ
A2	0 ~ 1800 °C (-32 ~ 3272 °F)	±1 °C	3.12MΩ
A3	0 ~ 1800 °C (-32 ~ 3272 °F)	±1 °C	3.12MΩ
M	-200 ~ 100 °C (-328 ~ 212 °F)	±1 °C	3.12MΩ
PT50 (α = 0.00385)	-200 ~ 850 °C (-328 ~ 1562 °F)	±0.4 °C	2.0KΩ

PT100	-200 ~ 850 °C	±0.4 °C	2.0KΩ
(α = 0.00385)	(-328~ 1562 °F)		
PT200	-200 ~ 850 °C	±0.4 °C	2.0KΩ
(α = 0.00385)	(-328 ~ 1562 °F)		
PT500	-200 ~ 850 °C	±0.4 °C	2.0KΩ
(α = 0.00385)	(-328 ~ 1562 °F)		
PT1000	-200 ~ 350 °C	±0.4 °C	2.0KΩ
(α = 0.00385)	(-328 ~ 662 °F)		
PT50	-200 ~ 850 °C	±0.4 °C	2.0KΩ
(α = 0.00391)	(-328 ~ 1562 °F)		
PT100	-200 ~ 850 °C	±0.4 °C	2.0KΩ
(α = 0.00391)	(-328 ~ 1562 °F)		
JPT50	-200 ~ 600 °C	±0.4 °C	2.0KΩ
(α = 0.003916)	(-328 ~ 1112 °F)		
JPT100	-200 ~ 600 °C	±0.4 °C	2.0KΩ
(α = 0.003961)	(-328 ~ 1112 °F)		
JPT200	-200 ~ 600 °C	±0.4 °C	2.0KΩ
(α = 0.003916)	(-328 ~ 1112 °F)		
JPT500	-200 ~ 600 °C	±0.4 °C	2.0KΩ
(α = 0.003916)	(-328 ~ 1112 °F)		
JPT1000	-200 ~ 350 °C	±0.4 °C	2.0KΩ
(α = 0.003916)	(-328 ~ 662 °F)		
Cu50	-50 ~ 200 °C	±0.4 °C	2.0KΩ
(α = 0.00426)	(-58 ~392 °F)		
Cu100	-50 ~ 200 °C	±0.4 °C	2.0KΩ
(α = 0.00426)	(-58 ~392 °F)		
Cu50	-180 ~ 200 °C	±0.4 °C	2.0KΩ
(α = 0.00428)	(-292 ~392 °F)		
Cu100	-180 ~ 200 °C	±0.4 °C	2.0KΩ
(α = 0.00428)	(-292 ~392 °F)		
Ni100	-60 ~ 180 °C	±0.4 °C	2.0KΩ
(α = 0.00617)	(-76 ~356 °F)		
Ni200	-60 ~ 180 °C	±0.4 °C	2.0KΩ
(α = 0.00617)	(-76 ~356 °F)		
Ni500	-60 ~ 180 °C	±0.4 °C	2.0KΩ
(α = 0.00617)	(-76 ~356 °F)		
Ni1000	-60 ~ 180 °C	±0.4 °C	2.0KΩ
(α = 0.00617)	(-76 ~356 °F)		
Cu10	-200 ~ 260 °C	±1.0 °C	2.0KΩ
(α = 0.00427)	(-328 ~500 °F)		
+20mA	-26 ~ 26mA	±0.05%	75Ω
+60mV	-122~122mV	±0.05%	3.12MΩ
+200mV	-243~243mV	±0.05%	3.12MΩ
+1V	-1.58~1.58V	±0.05%	3.12MΩ
+2V	-3.16 ~ 3.16V	±0.05%	3.12MΩ
+6V	-6.32 ~ 6.32V	±0.05%	3.12MΩ
+20V	-25.3 ~ 25.3V	±0.05%	3.12MΩ
+50V	-50.6 ~ 50.6V	±0.05%	3.12MΩ
0.4 ~ 2V	-3.16 ~ 3.16V	±0.05%	3.12MΩ
1~5V	-6.32 ~ 6.32V	±0.05%	3.12MΩ

### **Digital Input Card (DI206) :**

Channels: 6 per card  
Logic Low: -5V minimum, 0.8V maximum  
Logic High: 3.5V minimum, 24V maximum  
External pull-down Resistance: 1K $\Omega$  maximum  
External pull-up Resistance: 1.5M $\Omega$  minimum

### **Relay Output Card (RO206) :**

Channels: 6 per card  
Contact Form: N.O. & N.C. (form C)  
Relay Rating: 5A/240 VAC, life cycles 200,000 for resistive load

### **Analog Output Card (AO206):**

Channels: 6 per card  
Output signal: 4-20mA, 0-20mA, 0-5V, 1-5V, 0-10V  
Resolution: 16 bits  
Accuracy:  $\pm 0.05\%$  of Span  $\pm 0.0025\%$  / $^{\circ}\text{C}$   
Load Resistance: 0-500 ohms (current), 10K ohms minimum (voltage)  
Output Regulation: 0.01% for full load change  
Output Setting Time: 0.1 second (stable to 99.9%)  
Isolation Breakdown Voltage: 1500VAC at 50/60Hz for 1 minute  
Integral Linearity Error:  $\pm 0.005\%$  of Span  
Temperature Effect:  $\pm 0.0025\%$  of Span / $^{\circ}\text{C}$

### **COMM Module (IF232 and IF485):**

Interface: RS-232 (1 unit), RS-485 or RS-422 (up to 247 units)  
Protocol: Modbus Protocol RTU mode  
Address: 1-247  
Baud Rate: 9.6 ~ 115.2 Kbits/sec.  
Measured data Bits: 7 or 8 bits  
Parity Bit: None, Even or Odd  
Stop Bit: 1 or 2 bits

### **Standard Ethernet Communication:**

Protocol: Modbus TCP/IP, 10/100 Base T  
Ports: AUI (Attachment Unit Interface) and RJ-45, Auto- detect capability

### **Real time clock accuracy vs. temperature inside of housing**

Temperature inside housing	typical error per month
10 ~ 40 $^{\circ}\text{C}$	18 seconds
0 $^{\circ}\text{C}$ or 50 $^{\circ}\text{C}$	52 seconds
-10 $^{\circ}\text{C}$ or 60 $^{\circ}\text{C}$	107 seconds

## **Environmental & Physical :**

Operating Temperature: 0 ~ 50 °C

Storage Temperature: -30 ~ 70 °C

Humidity: 20 to 90% RH (non-condensing), maximum relative humidity 90% is for ambient temperature up to 38°C decreasing linearly to 50% relative humidity at 50°C

Altitude: 2000 M maximum

Insulation Resistance: 20 M ohms min. (at 500 VDC)

Dielectric Strength: 2300VAC, 50/60 Hz for 1 minute between power terminal and earth

Vibration Resistance: 10-55 Hz, 10m/ s<sup>2</sup> for 2 hours

Shock Resistance: 30m/ s<sup>2</sup> (3g) for operation, 20g for transportation

Operation Position: no inclined restriction

Dimensions: Panel Mount style: 144(W) x 144(H) x 193mm(D) (for WH10/20)  
288(W) x 288(H) x 194mm(D) (for WH30)

Standard Panel Cutout: 137 x 137mm (for WH10/20)  
281 x 281mm (for WH30)

## **ApWHoval Standards :**

Safety: UL61010C-1, CSA C22.2 No. 24-93

CE: EN61010-1 (IEC1010-1) over voltage category II, Pollution degree 2

WHotective Class: IP 65 front panel for indoor use,  
IP 20 housing and terminals

EMC:

Emission: EN61326-1 (EN55022 class A, EN61000-3-2, EN61000-3-3)

Immunity: EN61326-1 (EN61000-4-2, EN61000-4-3, EN61000-4-4,  
EN61000-4-5, EN61000-4-6, EN61000-4-8, EN61000-4-11)

## 2. Installation and wiring

### 2.1 Unpacking

If any damage is found while unpacking, the user should contact the local reWHesentative at once. It is suggested that the special packaging is retained for possible future requirement.

### 2.2 Installation



**Remove stains from this equipment using a soft, dry cloth. Don't use harsh chemicals, volatile solvent such as thinner or strong detergents to clean the equipment in order to avoid deformation.**

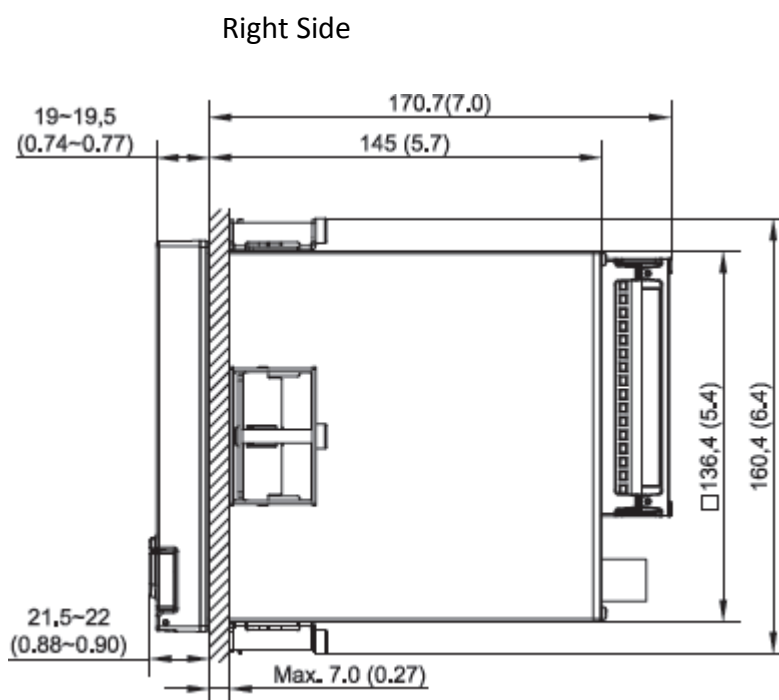
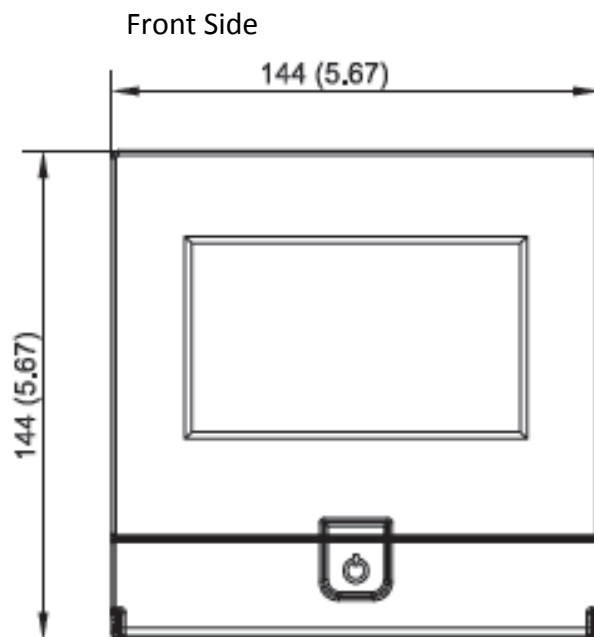
The recorder is designed for indoor use and not in any hazardous area. It should be kept away from shock, vibration, and electromagnetic fields such as variable frequency drives, motors and transformers.

It is intended to operate under the following environment:

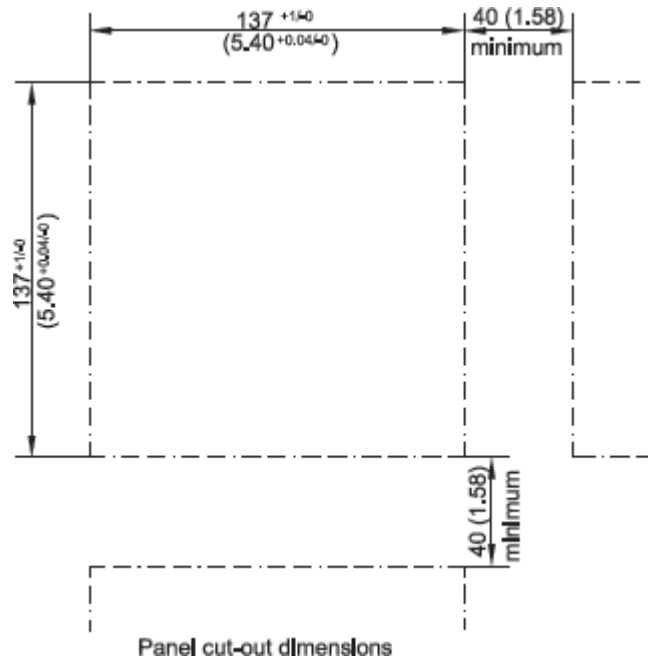
Pollution Degree Level II	IEC1010-1(EN61010-1)
Temperature	0 ~ 50 °C
Humidity	20 ~ 90 % RH (non-condensing)
Power	90 ~ 250 VAC, 50/60 Hz or 11-36VDC
Altitude	2000M maximum

### 2.3 Panel mounting style

WH10:

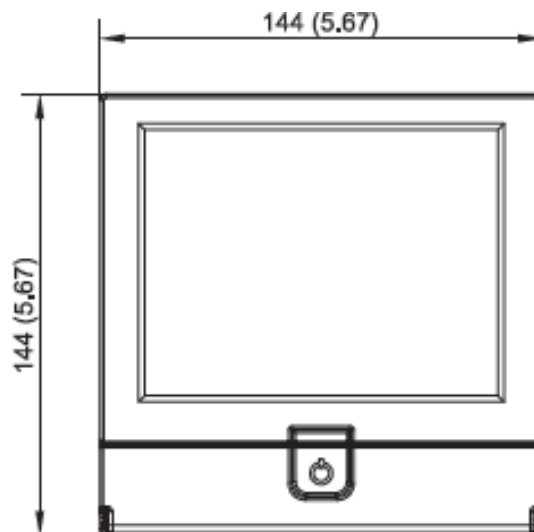


### Panel Cut Out Dimensions

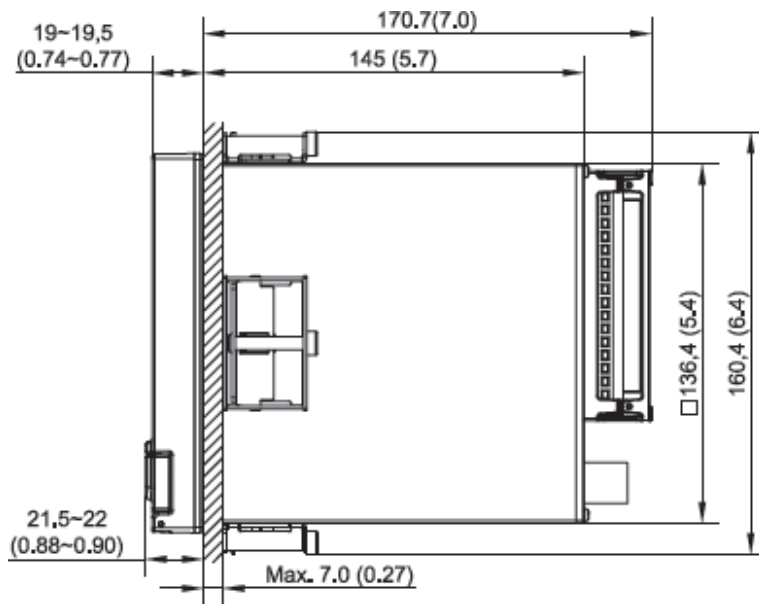


WH20:

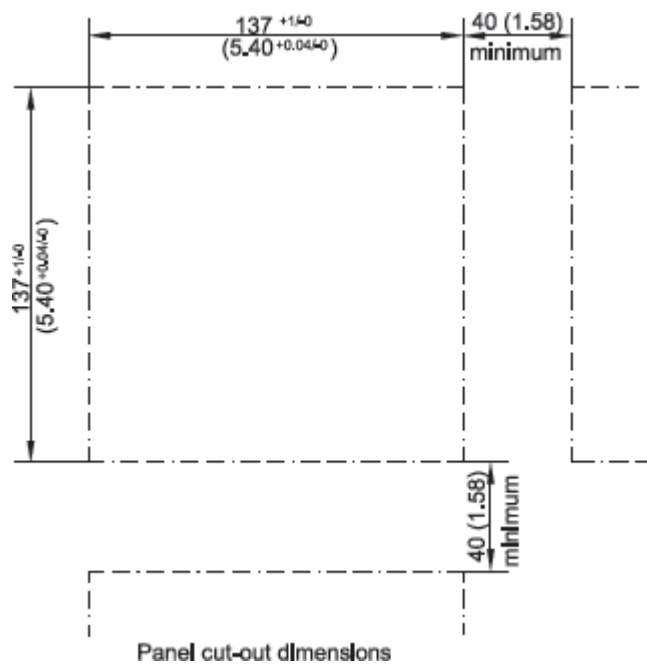
Front Side



### Right Side

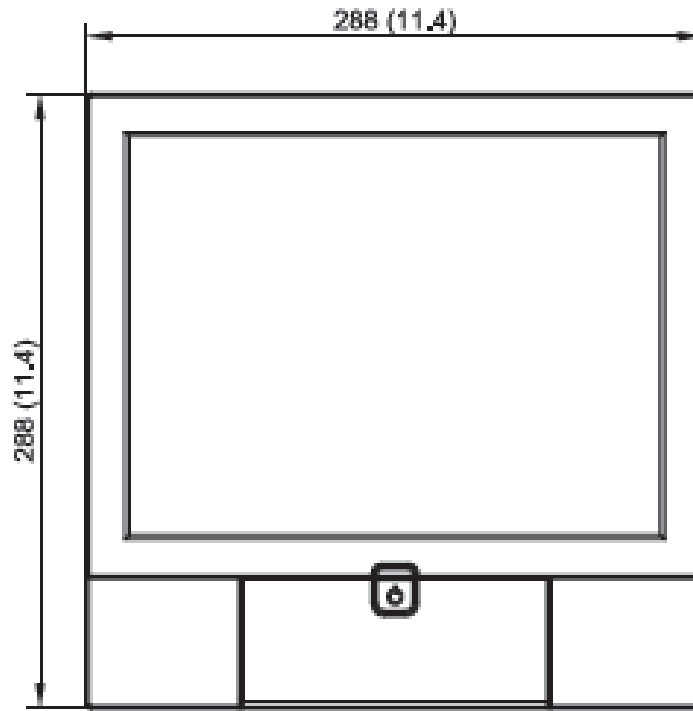


### Panel Cut Out Dimensions

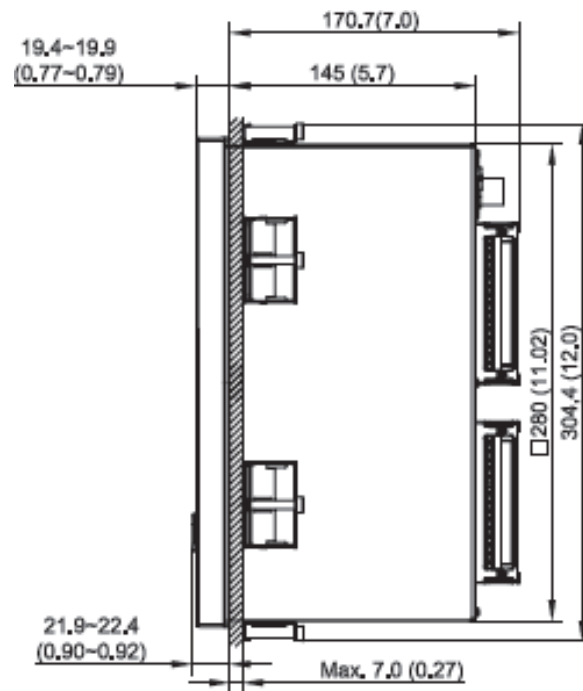


WH30:

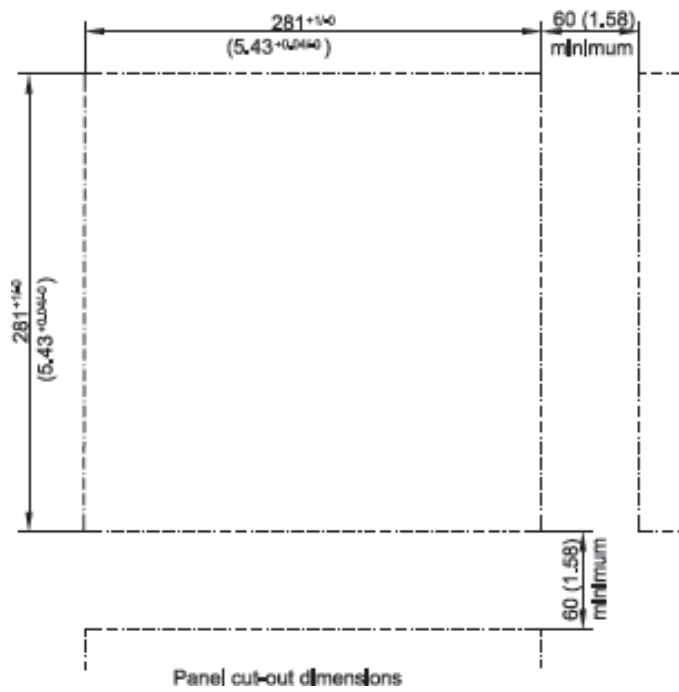
Front Side



Right Side



## Panel Cut Out Dimensions



### Note:

- ◆ Do not over tighten mounting clamp screws that could result in distortion of the case.
- ◆ There is no mounting angle restriction.

**Portable styles:**

**Portable recorders**



**PR10**



**PR20**



**PR30**

## 2.4 Setup input and output

### Analog input cards ( part numbers AI206 and AI203)

**AI206 and AI 203** are analog input cards in 3 and 6 channels respectively. Each card includes universal input of TC ( J, K, T, E, B, R, S, N, L,U,P,W5,W3,LR,A1,A2,A3,M ), RTD, mV, mA, V. The accepted input types and sensor range for each type are listed on the clause 1.8 of chapter 1. To plug the card into the rear slot then power on. The recorder will automatically detect the card and display the specific input type, then show its source of a specific slot in Configuration Mode.

To select a specific input, please WHess menu and then Config button to get into the configuration window. In the configuration window, WHess up/down and enter key to select AI and get into AI setting window. In the AI setting window, move the selected focus to the item "Type" under the node "Sensor" and then WHess enter key to select the desired sensor type. WHess OK when finished. It's similar to set up for all the other items. The item "Events" can be added to do further control.

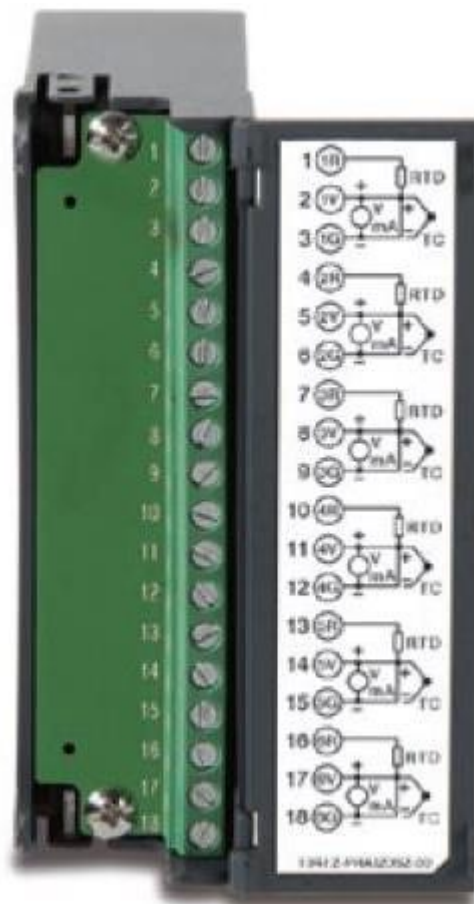


Figure 2 – 15 (AI206)

## Relay Output card ( RO206 ) / 6 relay alarm card

The relay output card includes 6 relays rated 5 Amp/240 VAC. Plug the card into rear slot and power on. The recorder will automatically detect the card and then display the output type and its source of a specific slot in **System Info** mode whilst doing the configuration.

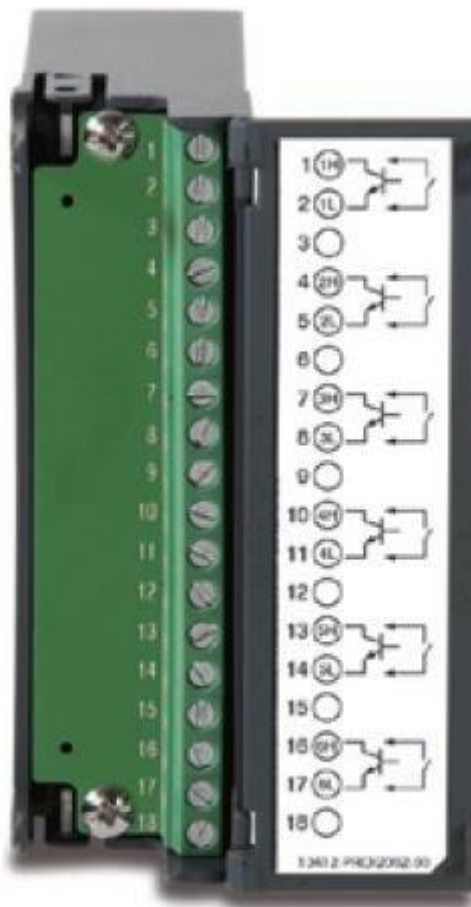
To set up the relay output card, please WHess menu and then Config button to get into the configuration window. In the configuration window, WHess up/down and enter key to select DO and get into DO setting window. In the DO setting window, the setup steps are similar to AI. The item "Reverse" is to reverse the output status.



## Digital Input card ( DI206 )

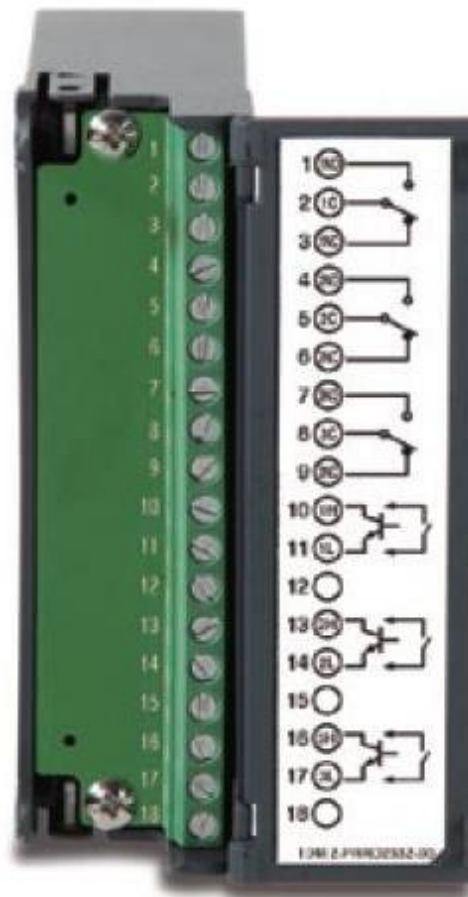
This card includes 6 channels of event 1, 2, 3, 4, 5 & 6. As above, plug the card into rear slot and power on. The recorder will automatically detect it, and then display the input type and its source of a specific slot in System Info mode whilst doing the configuration.

To set up the digital input card, please WHess menu and then Config button to get into the configuration window. In the configuration window, WHess up/down and enter key to select DI and get into DI setting window. In the DI setting window, the setup steps are similar to AI. The item "Type" is to decide for this channel to input logic level or Pulse Counter. If you select Pulse Counter, the item "Frequency" will appear for you to select input frequency(100Hz, 1KHz or 10KHz). The item "Events" can be added to do further control.



### Combination Digital Input and Output card ( RD233)

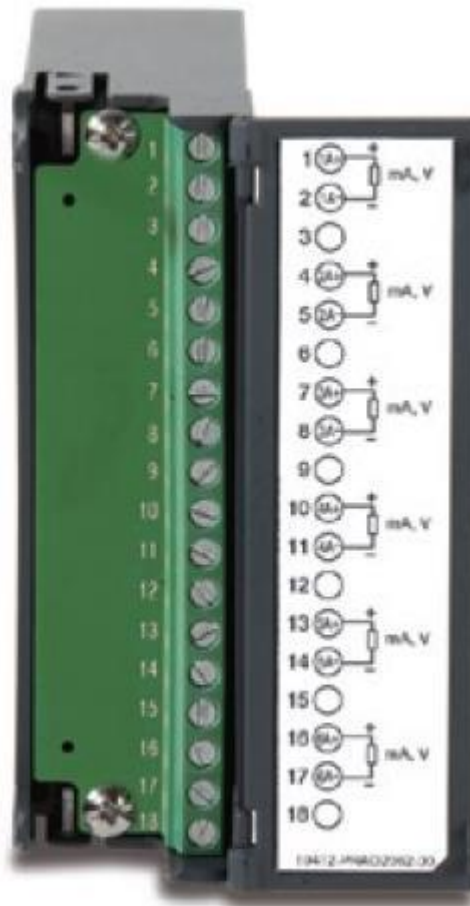
This card includes 3 relays rated 5 Amp/240 VAC and 3 Channels of Digital Inputs .As above, plug the card into rear slot and power on. The recorder will automatically detect it, and then display the input type and also Relay. The first 3 combination are for relays ( Terminal 1 to 9) and last 3 combination are for Digital inputs ( Terminals 10 to 18). The setup is similar to relay output card and digital input card.



## Analog output cards ( AO206)

This card are 6-channel current output card. They are used to retransmit WHocess value to another device.

To set up the analog output card, please WHess menu and then Config button to get into the configuration window. In the configuration window, WHess up/down and enter key to select AO and get into AO setting window. In the AO setting window, the setup steps are similar to AI. The item "Type" is to decide to output current or voltage. The item "Output" is to select the output range for current or voltage. The item "ExWHession" is a math exWHession field and can be inputted to control the output value.

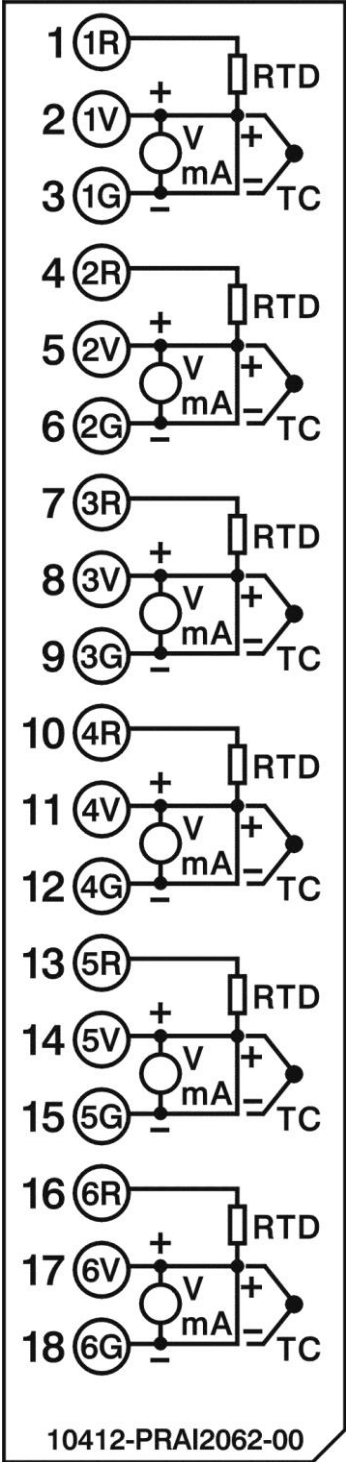


**Note : The IO Cards should not be removed or Inserted to the WH when the Power is ON. This should be carried out at Power OFF Condition only.**

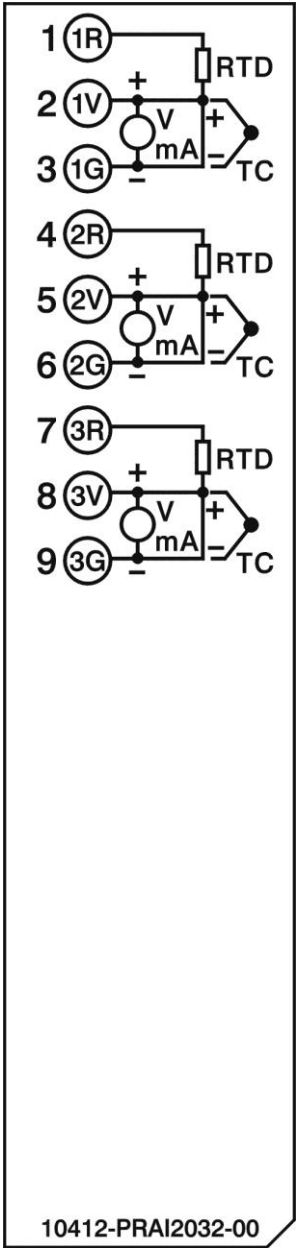
## 2.5 Wiring of the cards

### Wiring WHecautions

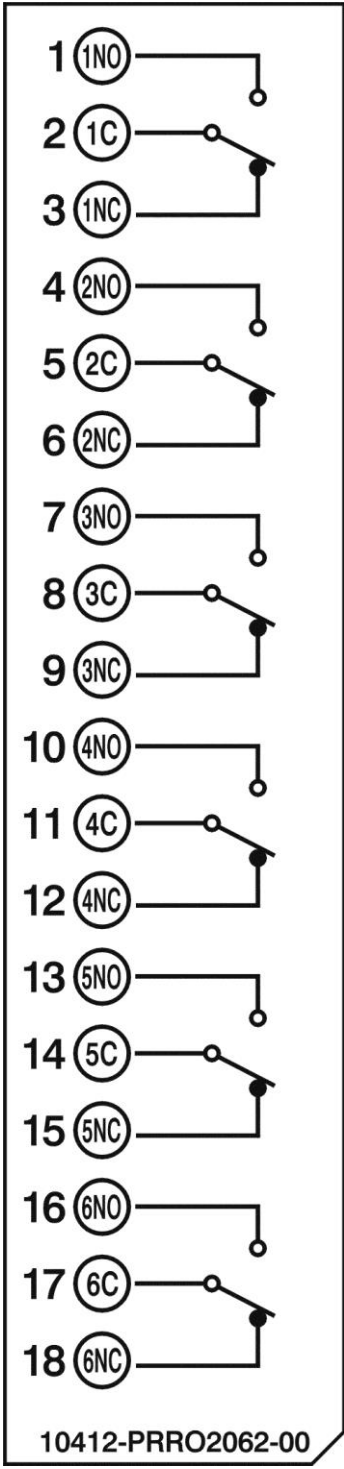
1. Care must be taken to ensure that maximum voltage rating specified on the label is not exceeded.
2. For the panel-mount version, it is recommended that near the equipment an external fuse and an external switch rated at 2A/250 VAC should be equipped.
3. Beware not to over tighten the terminals screws. The torque should not exceed 0.4 N-m ( 3.6 Lb-in or 4.0 Kg F-cm ).
4. Except the thermocouple wirings, all wirings should be stranded copper conductor with maximum gauge 18 AWG.
5. Connect a grounding conductor with 1.6mm diameter minimum to WHovide WHotective grounding WHior to turning on the equipment.



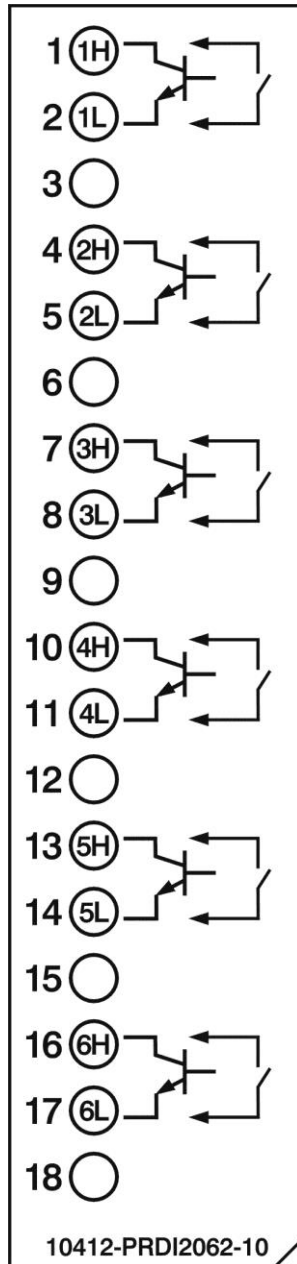
Analog Input Card AI206



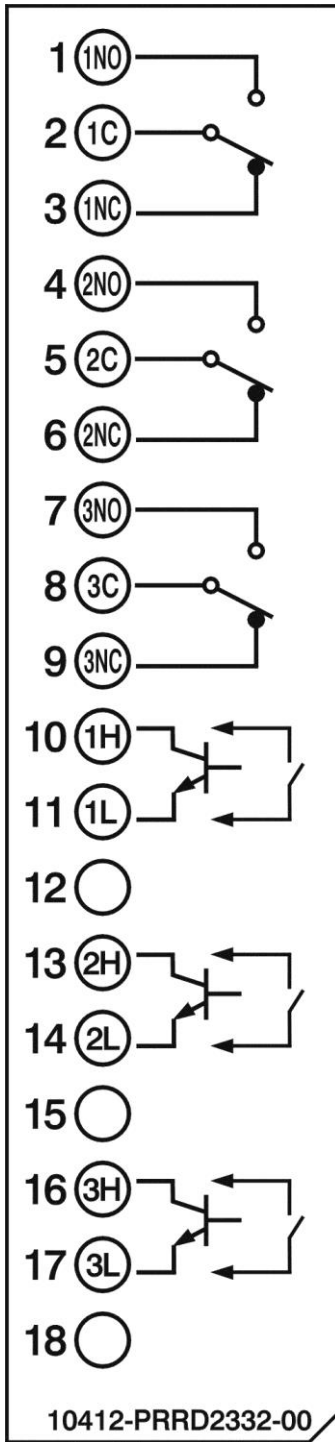
Analog Input Card AI203



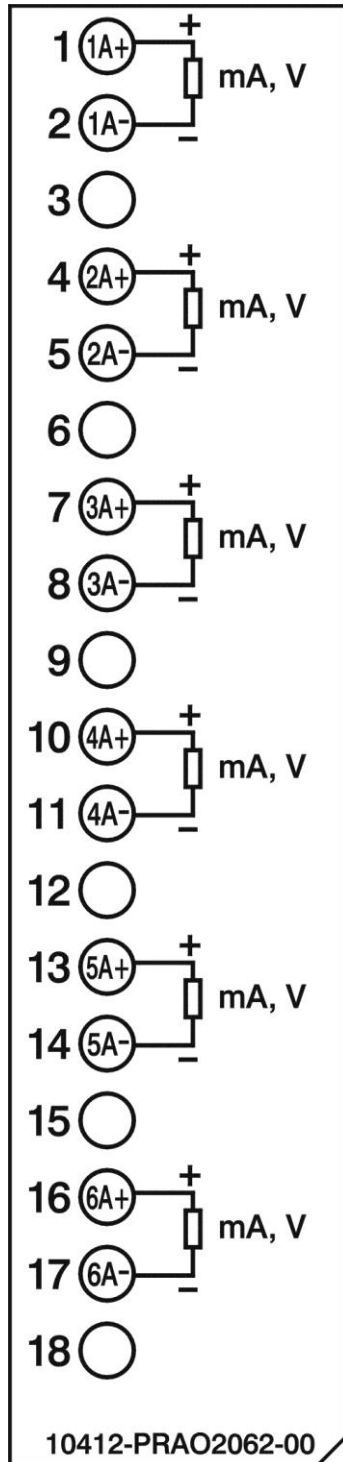
Relay output card ( RO206 )



Digital input card ( DI206 )

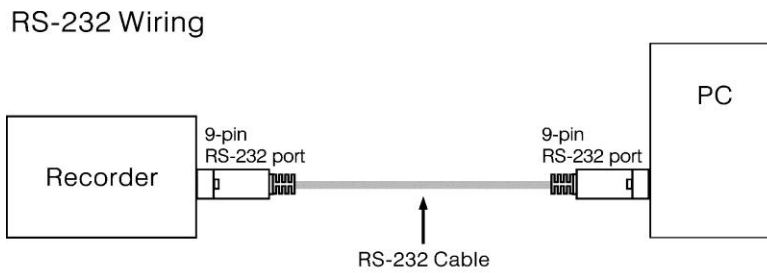


Relay output and digital input card ( RD233 )



Analog output card (AO206)

## 2.6 RS-232, RS-422, RS-485 wiring

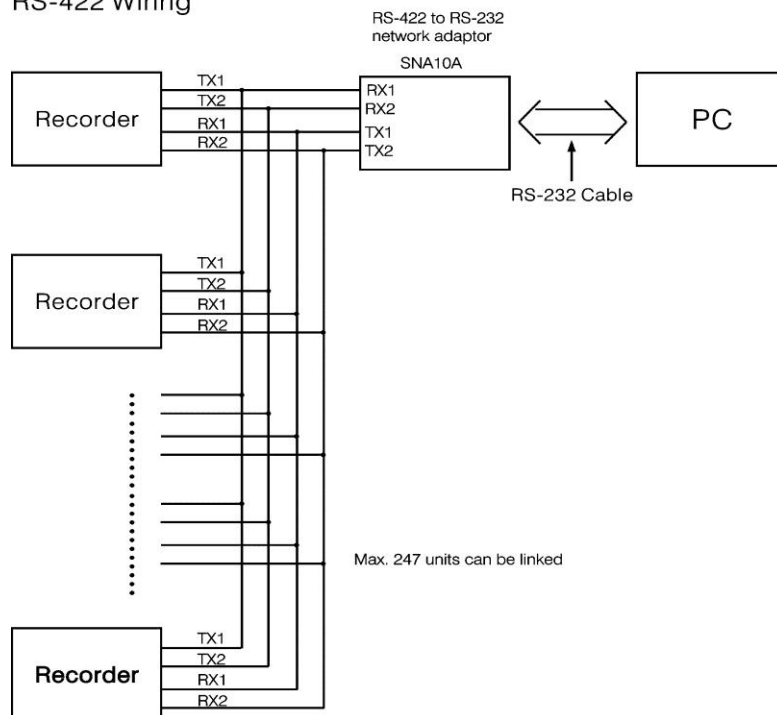


### Configuration of The RS-232 Cable

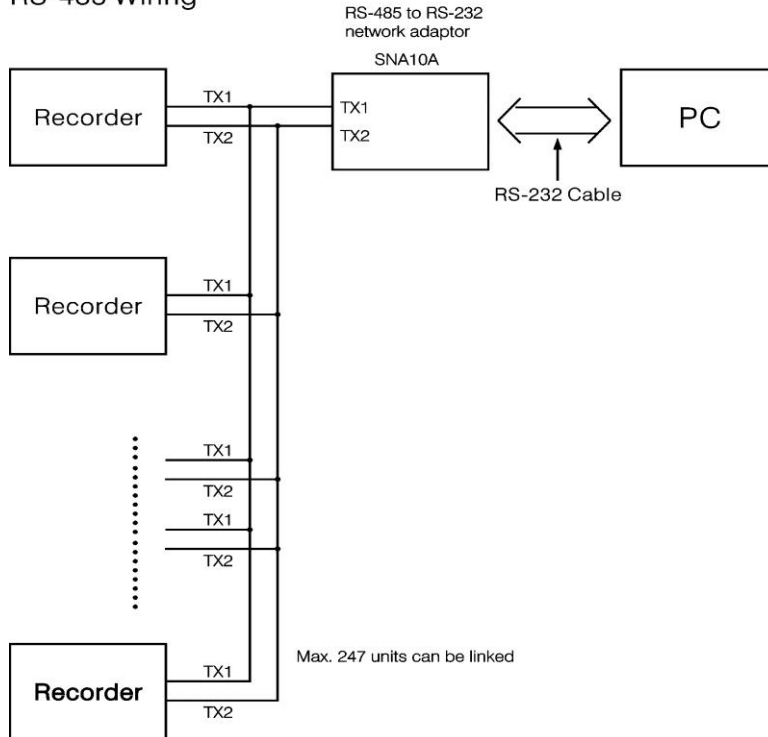


Figure 2 – 24

### RS-422 Wiring

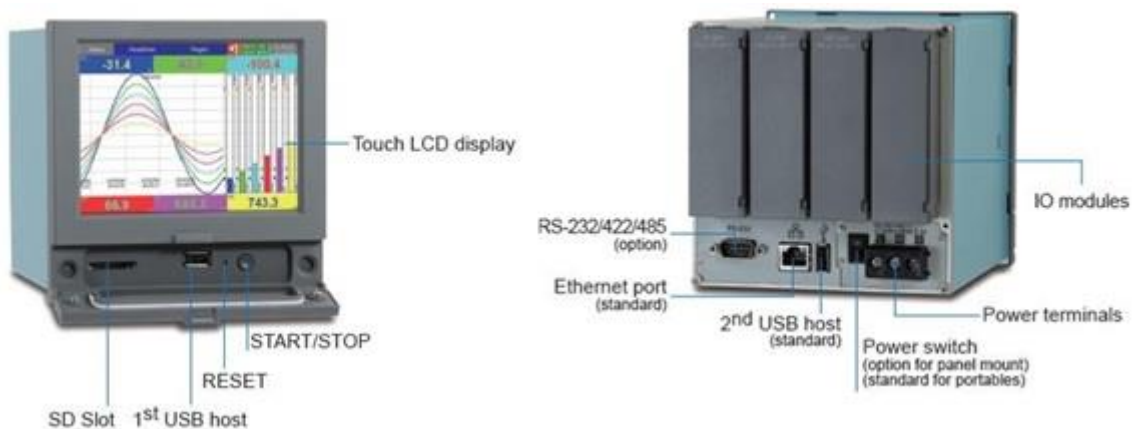


## RS-485 Wiring



## 2.7 External Memory Card :

There are two types of external storage for the User. One is the SD card and the other is the USB pen Flash Card. We have got two slots for inserting USB flash, one in the front and one in the rear side. If a bigger capacity USB pen flash memory is required, and the user may decide to buy it locally. The SD card slot is on the front side. Please check the below figures for more information.



**Note:**

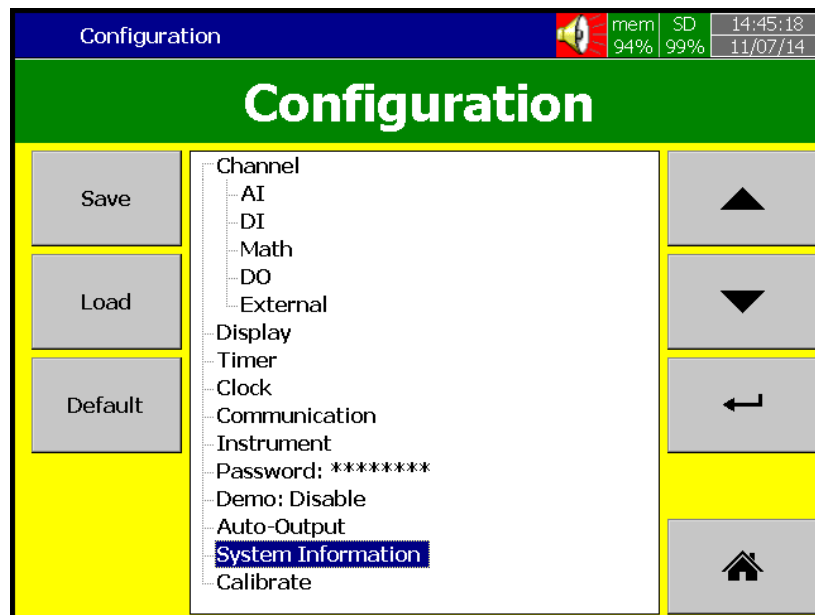
- ◆ To read measured data and events on USB flash memory and SD card Memory, it is necessary to install software free basic software or Extensive Data Acquisition software on PC first.
- ◆ The power should be turned off while inserting input and output cards. It is not recommended to insert input or output cards while the unit is switched on.

### 3. BASIC FUNCTIONS OF RECORDERS

In this chapter we will be explaining briefly about the functions that are available in the recorder.

#### 3.1 Configuration

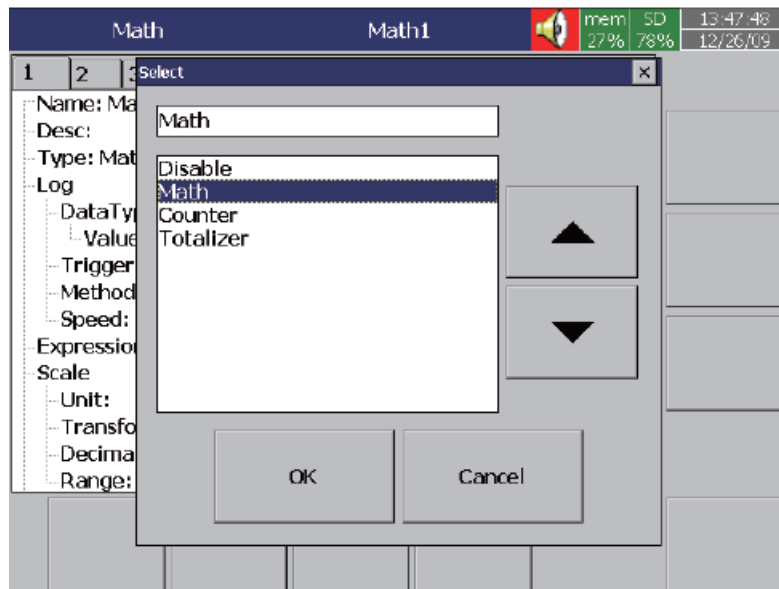
The configuration in the recorder is following a tree type layout, which is easy for operation for the users to go the different sub menus easily and not miss any setting.



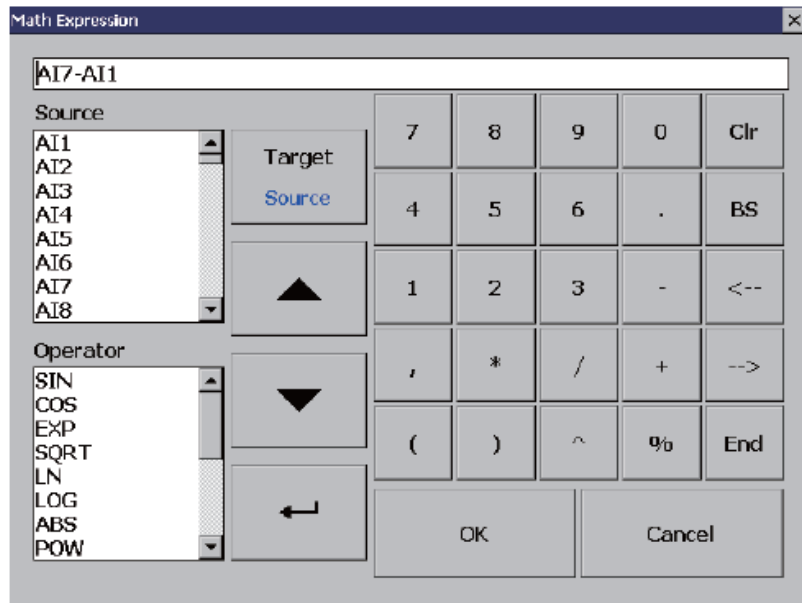
#### 3.2 Standard and Plus Version of Firmware

The standard version of firmware will be having only Input configuration and does not include Math, External channels, Custom Edited Display , Batch and FDA CFR part11 functions . While the plus version included all the above.

**Math:** It includes Math, Counter & Totalizer.



Math Expression is keyed in an easy way.



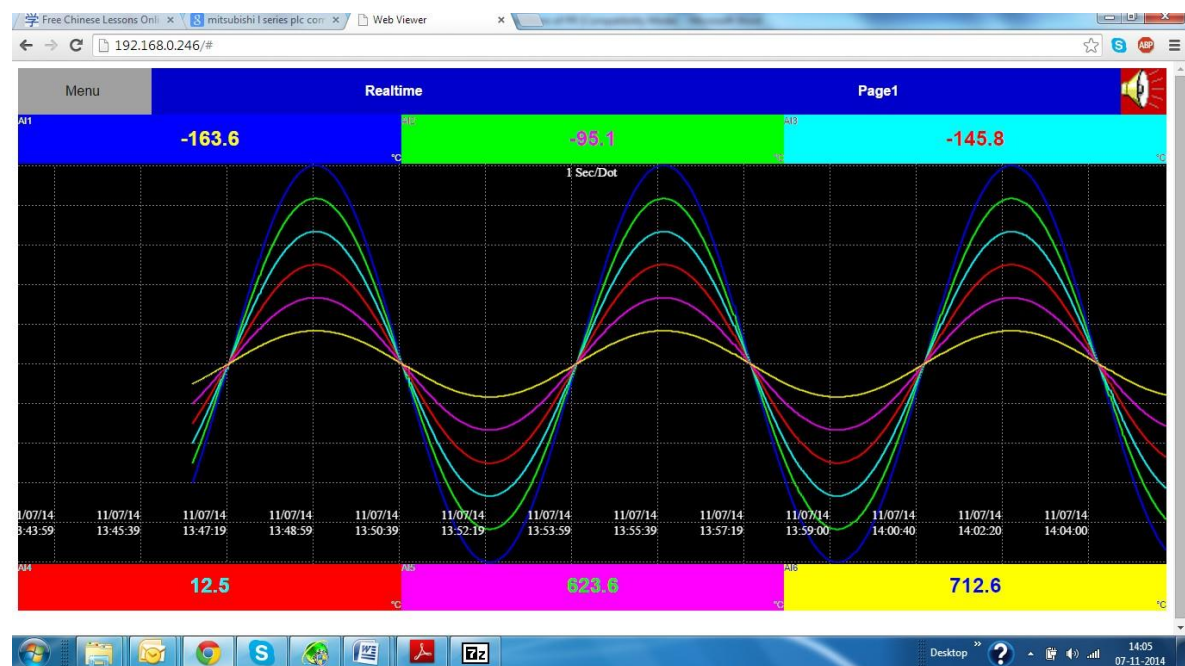
### 3.3 Communication with Third Party Interfaces

The flexibility that Recorder can communicate with Third party Interfaces on WHotocols Modbus TCP/IP or Serial as a Master or Slave. The detailed settings related information can be found in Chapter 4 , Configuration, Section 4.5.

### 3.4 Information Accesebility through WEB

Web Server :

The Recorder Trend and Digital data can be viewed in any place of world as we have got Web Server connectivity . For this the Recorder should be connected to Internet with a fixed IP WHovided by Internet Service WHovider.




Email:

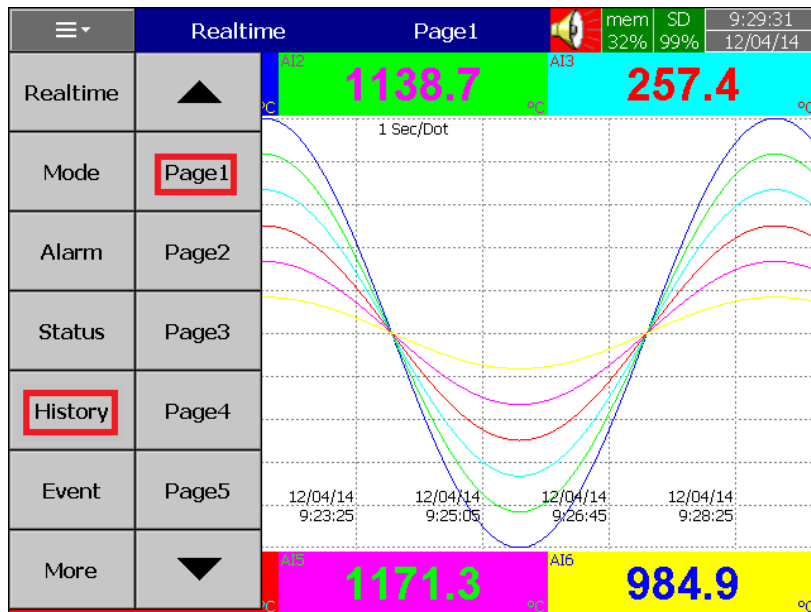
All Important Data events can sent as a email to the concerned personnel . The detailed settings related information can be found in Chapter 4 , Configuration, Section 4.5.

### 3.5 Handwriting Messages on Trend Screens

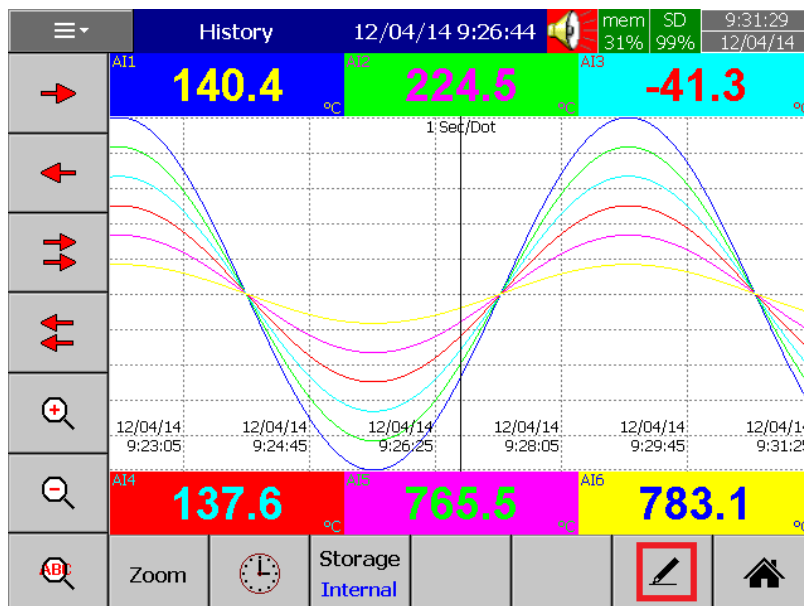
Handwriting Messages on Trend Screens are very handy for WHocess associates to highlight the important events.

The User can write Handwritten messages using stylus on Historical Trend Screens . This is shown in the below picture.

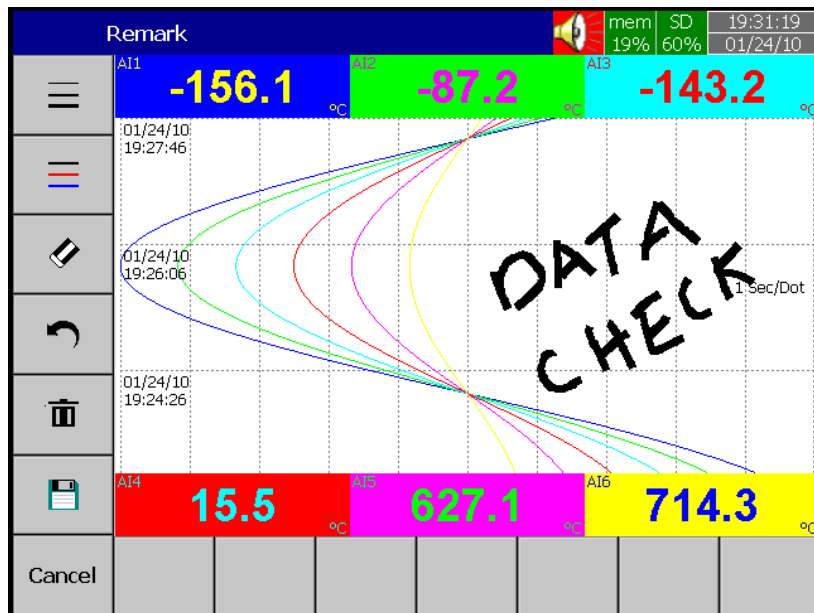
When the User navigates through  (Menu)-  $\rightarrow$  History  $\rightarrow$  Page 1, as shown in the below screen.



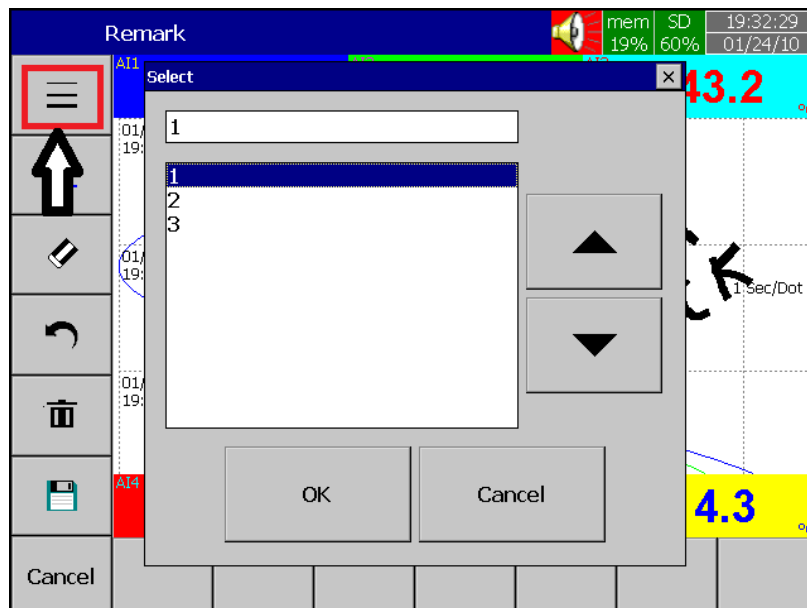
The User wants to write any message then WHess the pen symbol as shown squared in the below screen



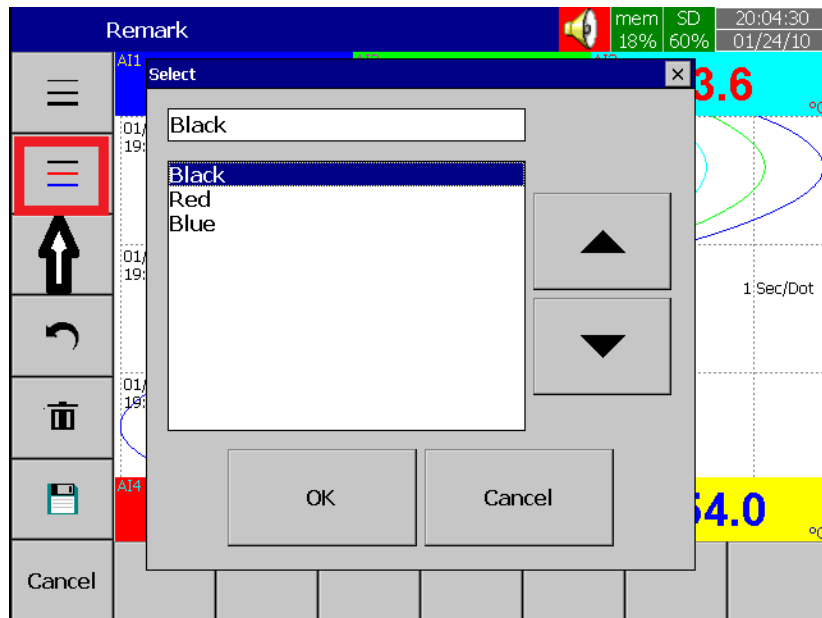
The User using the stylus can write any message as shown in the below screen in Historical Trend Pages.



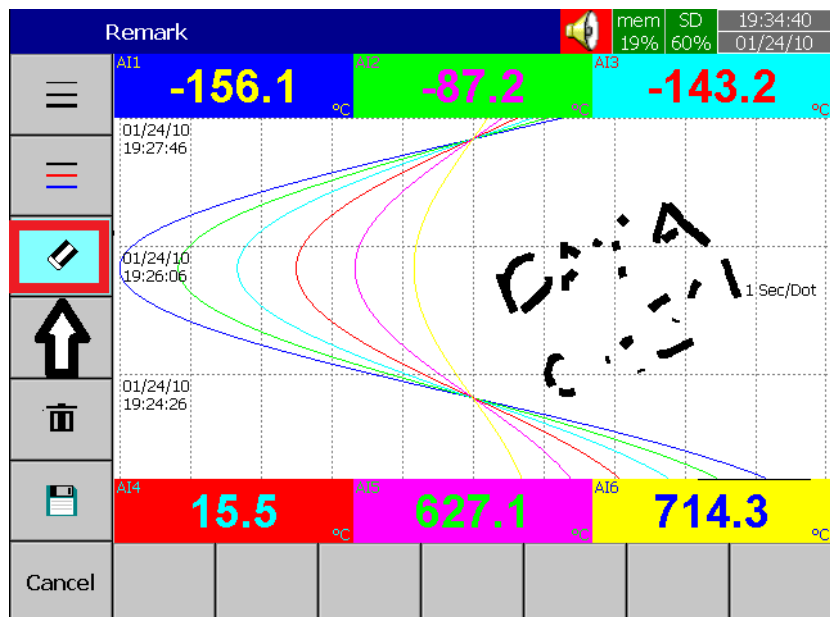
If the User wants to change the width of the written message he/she can choose the width of pen. This can be shown in the below screen. The menu to change the width is shown by the arrow



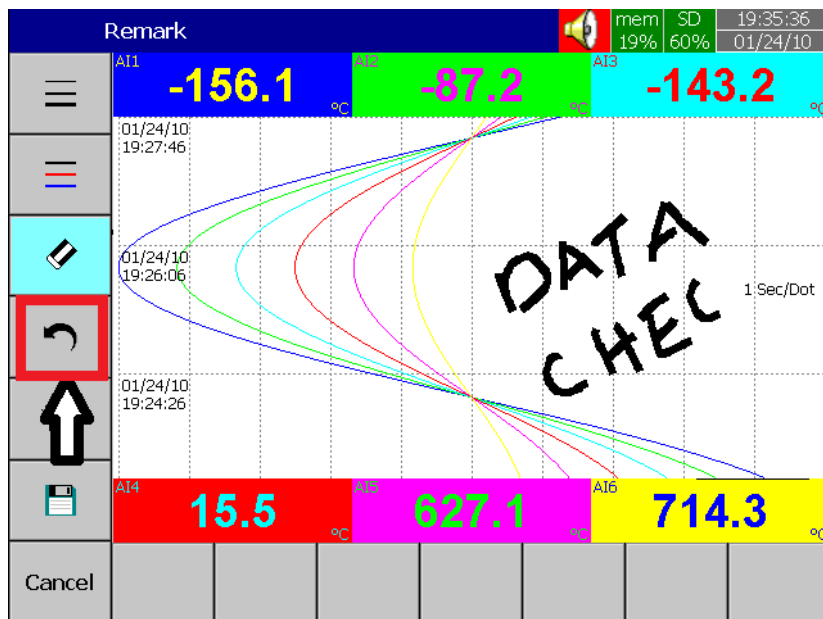
If the User wants to change colour of the pen. He/she can change by WHessing the menu,  
 this can be shown in the below screen ( the arrow points the menu)



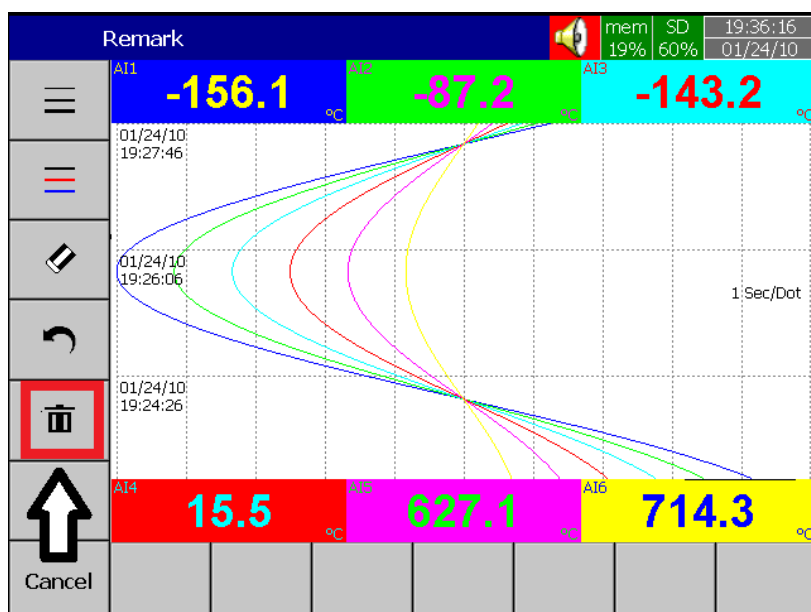
If the User wants to erase a part of message. He/she can do by WHessing the menu (shown in arrow), and erase part of the message. This is shown in below screen.



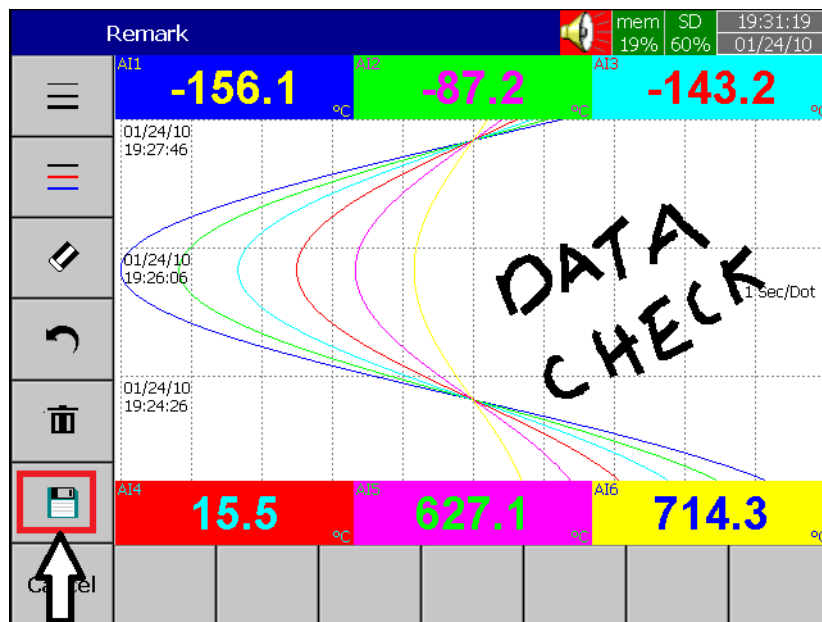
If the User wants to undo a part of message. He/she can do by WHessing the menu (shown in arrow), and will undo the part of the message. This is shown in below screen.



If the User wants to delete the written message. He/she can do by WHessing the menu (shown in arrow), and this will delete the written message. The same is shown in below screen.



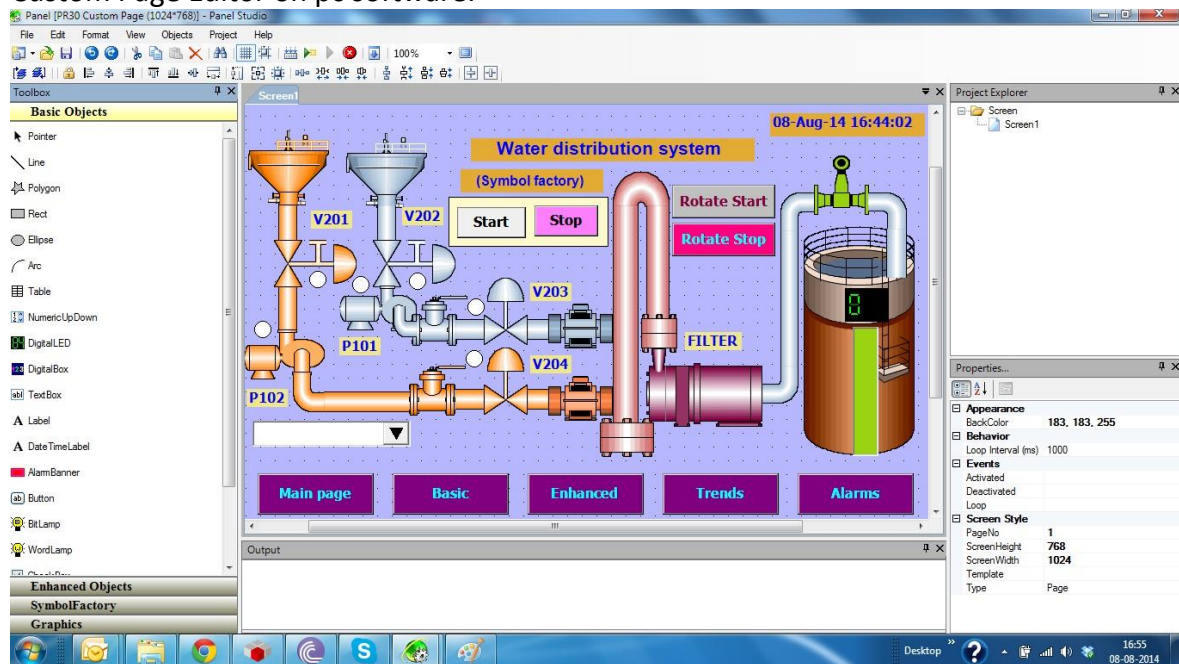
If the User wants to save the written message. He/she can do by WHessing the menu (shown in arrow below ), and this will save the written message. The same is shown in below screen.



### 3.6 Custom Edited Display Screens

(We call it Custom Page on device and Custom Page Editor on pc software)

In Plus versions, The PC software Panel Studio allows users to have custom edited displays linked with Analog and Digital Tags . We call it Custom Page on device and Custom Page Editor on pc software.



### **3.7 Analog Input Log Speed Flexibility**

The Analog input can be logged at various speeds such as 100ms, 1,2,5,10,20,50 sec/Dot and 1,2 Min/Dot. So the User has got lot of flexibility in logging speeds.

### **3.8 High Speed Input**

The Digital input can be accessed as normal Logic or a High frequency pulse.

### **3.9 System Clock Synchronization via Internet**

The Recorder System clock can be synchronized via internet and Summer Saving Time can be defined. The detailed settings related information can be found in Chapter 4 , Configuration, Section 4.4.

### **3.10 Increased Security in Password configuration**

The password can be configured as normal and CFR-21. For normal there is only one password defined but for CFR-21 three 9 levels of password definition. The related settings information can be found in Chapter 4 , Configuration, Section 4.7.

### **3.11 Auto Output to WHinter**

The daily or shift reports data can be WHinted automatically by the WHinter. The related settings information can be found in Chapter 4 , Configuration, Section 4.9.

### **3.12 External Channels**

Besides AI and DI inputs the Recorders can accept inputs through communication ( MODBUS). WH10,WH20,WH30 can work External Channels maximum up to 24,48 and 96 respectively. The related settings information can be found in Chapter 4 , Configuration, Section 4.1.6.


### **3.13 Batch**

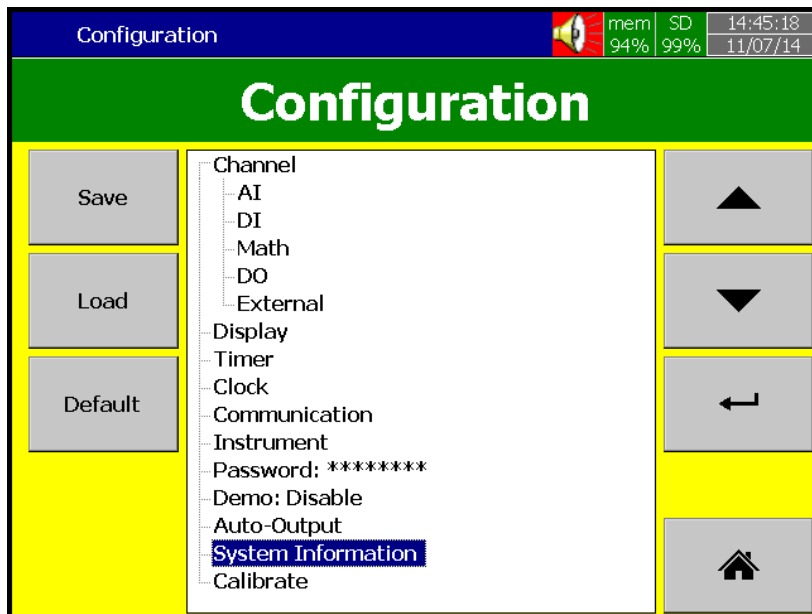
Using this function , the recorded data can be stored in batches as per shift. So that it will be easy for the WHoduction personnel for quality and quantity management.

### **3.14 FDA 21 CFR PART 11**

This feature is compiled with U.S. Food and Drug Administration with human health concern. When this feature is enabled the recorded data cannot be manipulated.

## 4. CONFIGURATION

WHess  ( "Menu"), then, "More" soft button to enter the Config ( Configuration mode ). A vertical list appears with a WHovision to configure Channel, Tools, Message, Display, Instrument, Security, Auto-Output, Demo and system Information. Meanwhile, the following soft buttons also appear Save, Load, Default and Home.



### Soft buttons



Enter key



Up directional key



Down directional key



Home key

Various options available to enter into configuration mode

Option-1: Select the mode by WHessing up & down directional keys, then WHess "Enter" key

Option-2: Select the required mode directly with a touch, then WHess "Enter" key

Option-3: Select the required mode and then WHess two times quickly using Touch, it is same as double click from mouse


**Save:** Save configuration from recorder to USB Stick or SD Card. *To read the configuration from USB Stick for the first time or any time configuration has been changed, it is important to WHess “Save” soft button to save configuration changes to USB Stick or SD Card beforehand.*

**Load:** Load configuration from storage media USB stick or SD Card to recorder.

**Default:** If the configuration is set incorrectly, Default is a useful key to recall the default settings on the analog input card inserted into rear expansion slot.

**Home:** Go to home page.

## 4.1 Channel

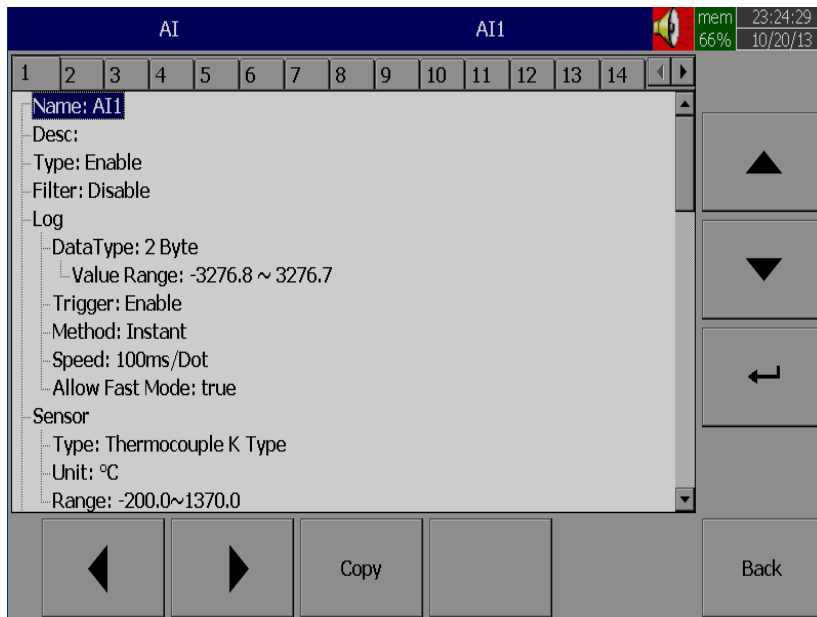
Path:  (Menu)-More-Config-Channel

```
├-- AI
├-- DI
├-- Math
├-- AO
├-- DO
└-- External
```

This section is to configure different type of channels. Analog Input (AI), Digital Input (DI), Math, Analog Output (AO), Digital Output and External device channels.

### 4.1.1 Analog Input

After entering the Configuration mode, in Channel, select “AI” then WHess the “Enter” key to get into Analog Input Channel mode. It displays the Analog input AI1, first analog input channel configuration page. WHess directional keys < > at the bottom to select other channels. WHess directional keys ↑ ↓ on the right hand side to select the column. **After completing Configuration, WHess “Back” soft button, then WHess “Home” soft button to return to main display, then, all configurations will be memorized.**



**Copy:** Copy the channel configuration say from channel1 to channel2 etc.. Select the source channel, say Channel1, WHess on “Copy” button, now “Paste” button will get enabled, go to target channel say channel2 and then WHess on “Paste” button.

**Name:** It is to define the name for each channel in maximum 18 characters.

Select “Name”, then WHess “**Enter**”, soft button, a keyboard with several keys appear. WHess on “**Shift**” to select special characters. WHess on “**Caps**” to select Capital letters. WHess soft key “**OK**” after entering channel name.

**Desc:** The description about a specific channel on the display.

**Type:** Option available to enable or disable the channel from selection

**Filter:** It is to reduce the noise of input signal before sampling. It is possible to select range from 1 to 16 sec. It is a soft filter available to reduce fast variation of analog inputs. It gives a moving average value. For ex: If filter value is set as 5 sec for AI1, it means, all the samples collected in the last 5 sec shall be averaged and value is available to record as per Log method.

**Log:**

**Data Type:** 2 byte

2 byte range: -32767 to +32767

**Trigger:** Two options are available

- a) Disable: Select disable while the recording of a specific channel is not required at this time
- b) Enable: Select Enable while the recording of a specific channel is required at this time

**Method:** This is method of logging measured data. Select the column and WHess enter and then choose the Log method of Instant, Average, Minimum or Maximum data.

**Instant:** logging in the last measured data at the sampling interval

**Average:** logging in averaged measured data at the sampling interval

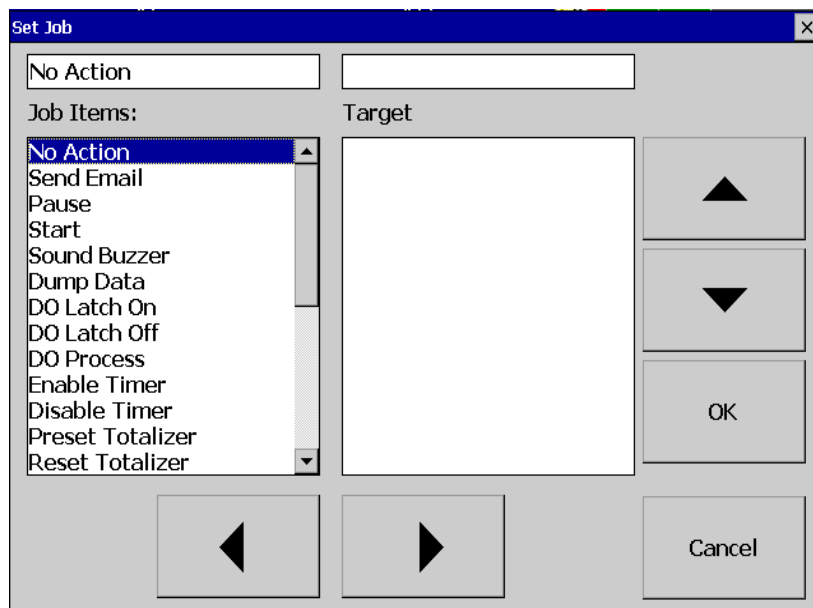
**Minimum:** logging in minimum measured data at the sampling interval

**Maximum:** logging in maximum measured data at the sampling interval

**Speed:** It is the logging speed (recording speed) of measured data. Select Log Speed column, then choose one of the following

- 100ms/Dot
- 1 Sec/Dot
- 2 Sec/Dot
- 5 Sec/Dot
- 10 Sec/Dot
- 20 Sec/Dot
- 30 Sec/Dot
- 1 Min/Dot
- 2 Min/Dot

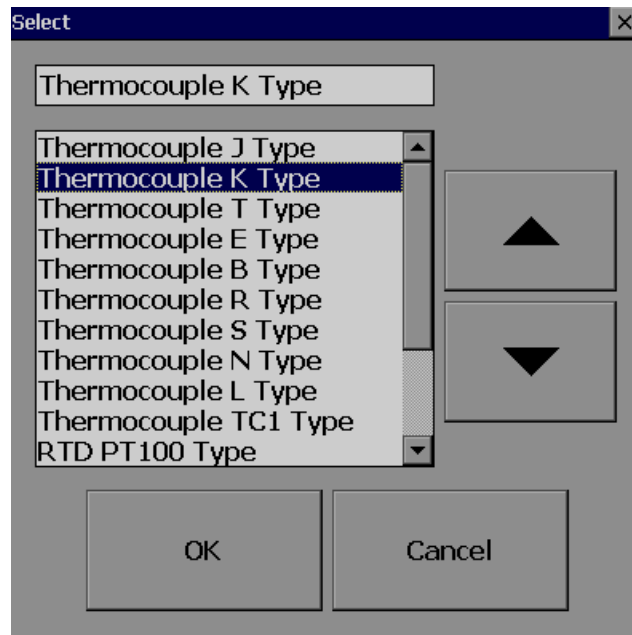
(Auto)Set Jobs under Events



## Sensor

- Type: Thermocouple K Type, °C
- Unit: °C
- Range: -200.0~1370.0

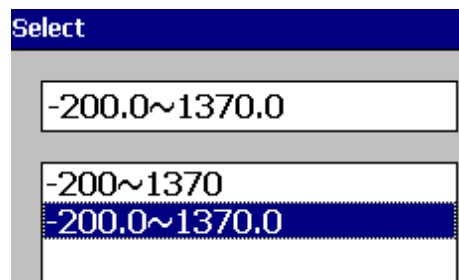
**Type:** Select the sensor input type for the Channel.

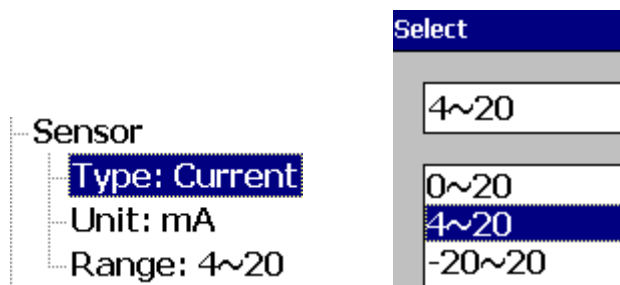
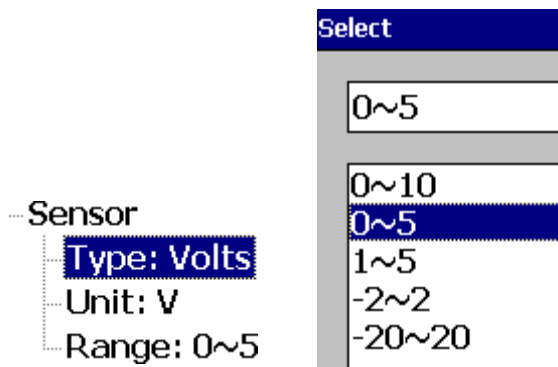
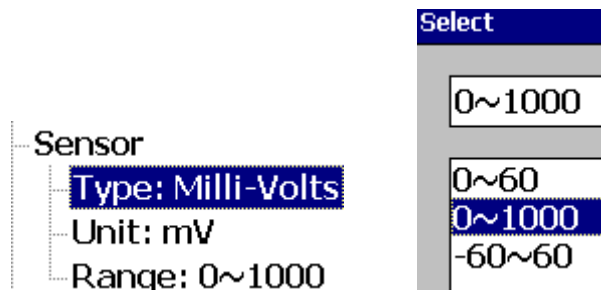


RTD JPT100 Type  
RTD RTD1 Type  
Milli-Volts  
Volts  
Current

**Unit:** The engineering unit of input.

**Range:** Select based on Sensor type





**Scale:** Appears only for linear input Ex: mV, Voltage, current etc..

**Scale**

Unit: °C  
 Low: -120.0  
 High: 1000.0

**Offset:** It is offset value to correct the sensor error.

**Gain:** It is a multiplier to correct the sensor error.

The correct value = (the WHocess value x gain) + offset

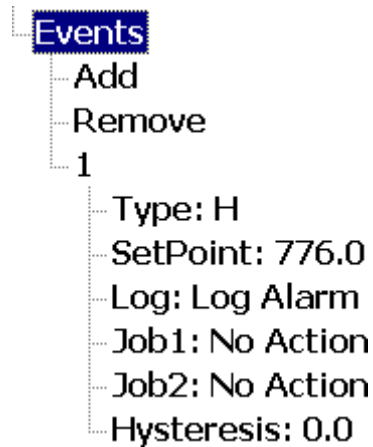
## Events

The Event is frequently used for Alarm purpose. Event can also be used for digital output DO, Timer, Totalizer, Counter or Report.

Maximum five events are possible to set for each Analog Input

WHess "Add" to add new event

WHess "Remove" to remove selected event



Type: There are various types of H, L, HH, LL, Dev+, Dev-, Error to be selected for job or Alarm purpose

**H:** High limit. When the WHocess is over high limit, the alarm or job is actuated.

**L:** Low limit. Any the WHocess is lower than low limit, the alarm or job is actuated

**HH:** High high limit, to set up another limit higher than high limit for double warning.

**LL:** Low low limit, to set up another limit lower than low limit for double warning.

**Dev+:** Trigger event on positive deviation of WHocess value. The job or alarm is activated when WHocess value is deviated by greater than (set point) earlier WHocess value.

For ex: Set point, Type: Dev +, Value: 10

At 10.00.01 Hrs, Tag1=40

At 10.00.02 Hrs, Tag1 = 51

Then, job or alarm is activated

**Dev-:** Trigger event on negative deviation of WHocess value .The job or alarm is activated when WHocess value is deviated by less than (set point) earlier WHocess value.

For ex: Set point, Type: Dev -, Value: 10  
At 10.00.01 Hrs, Tag1=40  
At 10.00.02 Hrs, Tag1 = 29

Then, job or alarm is activated.

**Error:** On channel error, an alarm or job is activated

**Setpoint:** To set up the WHocess value for actuating Job1 and /or Job2

### **Alarm**

**Log Alarm:** Record alarms

**Log Alarm (Auto Ack):** Record alarms and acknowledge automatically

**Log Event:** Record events

**Job1, Job2:** When an event occurs, the task to be performed is called the job. A typical example is to trigger **an alarm buzzer** in event of high temperature. Each pen can accept five different type of events (or alarms) and each event can create two jobs. Please note that a job under Event is different from a job by WHessing the **Operate** key. The former is actuated by an event, and the latter is actuated by manual control, no event necessary.

**Note:** *Please refer section Jobs for full details about various jobs available*

**Hysteresis:** To avoid it been activated too often, the Log Alarm or relay can set for no reaction. Hysteresis value can be defined for the event trigger set point

### **Example1**

If temperature is increased to more than 120 °C, log alarm and switch on digital output1. When temperature is decreased to less than 80 °C, log the alarm and switch off the digital output1.

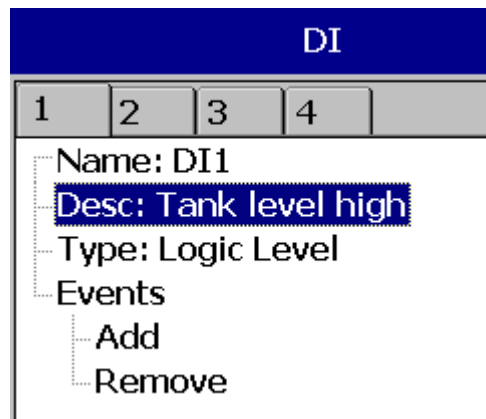
Setting of events for the analog input in the channel configuration is as follows..

Events	
Add	
Remove	
1	2
Type: H	Type: L
SetPoint: 120.0	SetPoint: 80.0
Log: Log Alarm	Log: Log Alarm
Job1: DO Latch On_DO1	Job1: DO Latch Off_DO1
Job2: No Action	Job2: No Action
Hysteresis: 0.0	Hysteresis: 0.0

#### 4.1.2 Digital Input

Path:  (Menu)-Config-DI

After entering the Configuration mode, in the Channel, select DI then Press the “Enter” soft button to get into Digital Input Channel configuration page.



**Name:** Define the name for the Digital Input Channel. Max 18 characters allowed for the name.

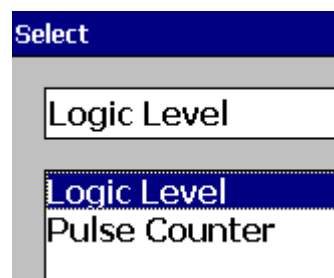
**Description:** Define detail description for the channel.

**Type:** Logic Level

Logic Level: This selection activates digital logic, which is either one or zero with low frequency which is less than 1Hz.

Pulse Counter: On This selection , we can feed high speed inputs ( high Frequency , up to 100Hz)

Select Logic Level and WHess “Enter” key



**Events:** Maximum 2 events are supported for every digital Input channel. Maximum two jobs can be configured for each event.

Note: Events will not appear if Logic Level selected as Pulse Counter

**Add:** WHess “Add” to add events to the Digital Input

**Remove:** WHess “Remove” to remove events from the Digital Input

**Type:** Select Low, L or High, H

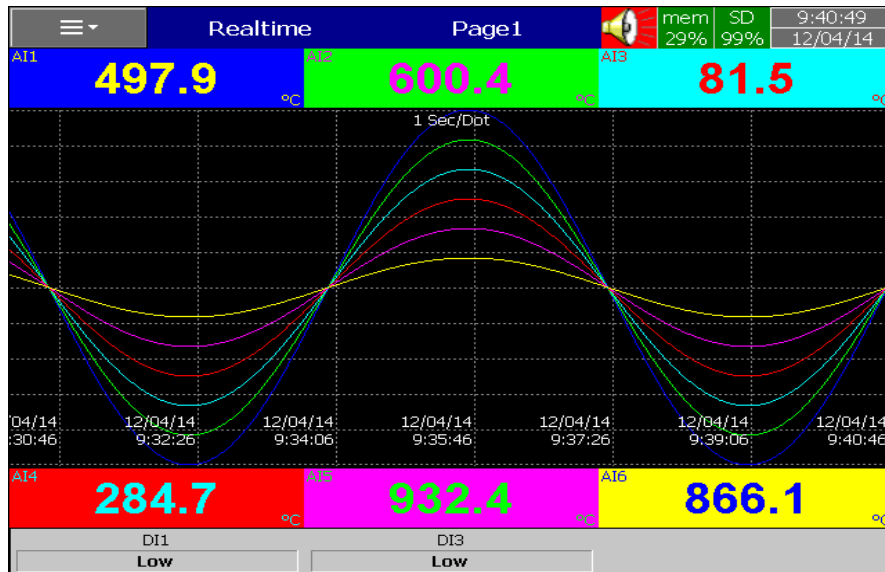
**Job1, Job2:** To configure Job, select Job1, WHess on Enter button. It will show list of all the jobs, select the required Job.

Note: Number of digital inputs shown at DI screen depends on number of Digital input cards inserted in the paperless recorder.


Sample applications of Digital input ...

After WHessing a “Start” switch at site, latch ON Digital Ouput1  
After WHessing a “Pause” switch at site, latch Off Digital Output1  
Start Timer, Stop Timer  
Reset Totalizer, Reset Counter  
Reset MaxMinAve values of all the channels etc..

It is possible to display Digital input status via status bar on any page in the paperless recorder. If digital input is not available, it shows as “Low”, WHesence of digital input shall be shown as “High”. To configure status bar, refer section “Display”



Status Bar and Digital Input Status


Digital Input status can also be monitored from the  (Menu). When on Status and then select "DI", it will show Digital Input Status as follows.

Menu		Status			DI	mem 84%	12:49:57
DI	DO	AO	Counter	Totalizer		SD 99%	02/17/13
No	Name			Value	Desc		
1	DI1			Hi	Tank1 Level switch high		
2	DI2			Low	Tank2 Level Switch High		

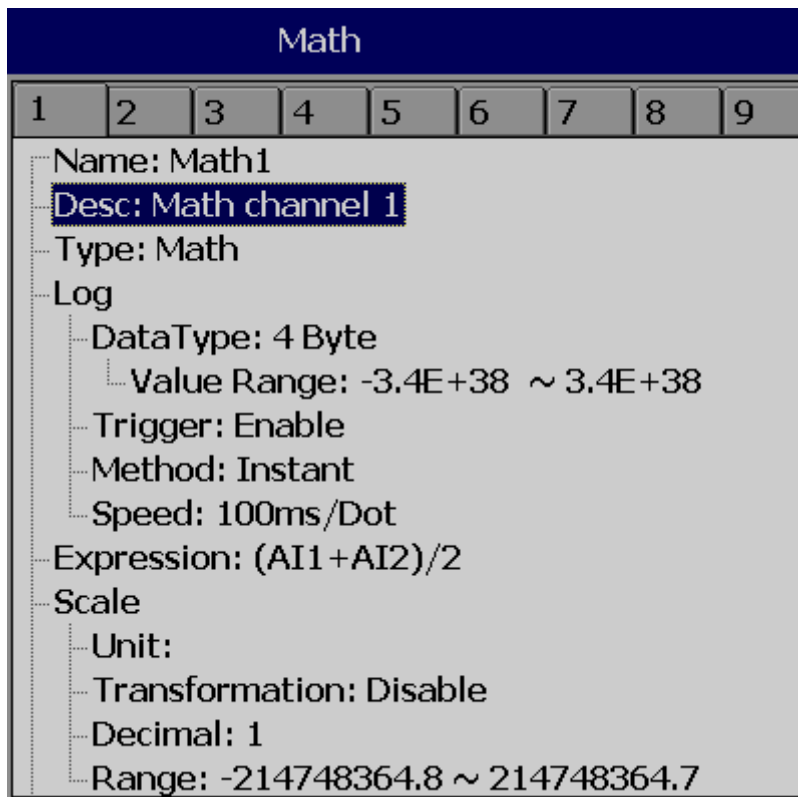
### 4.1.3 Math Channel

Maximum no. of Math channels in various WH series Recorders are as follows

WH Recorder	WH-10	WH-20	WH-30
Maximum Math Channels	15	40	60

Path:  (Menu)-More-Config-Math

After entering the Configuration mode, in the Channel, select Math, then WHess the “Enter” soft button to get into Math Channel configuration page.



Math

1	2	3	4	5	6	7	8	9
---	---	---	---	---	---	---	---	---

Name: Math1  
Desc: Math channel 1  
Type: Math  
Log  
  DataType: 4 Byte  
  Value Range: -3.4E+38 ~ 3.4E+38  
  Trigger: Enable  
  Method: Instant  
  Speed: 100ms/Dot  
Expression: (AI1+AI2)/2  
Scale  
  Unit:  
  Transformation: Disable  
  Decimal: 1  
  Range: -214748364.8 ~ 214748364.7

**Name:** Define name for the Math channel

**Desc:** Define detail description for the channel name

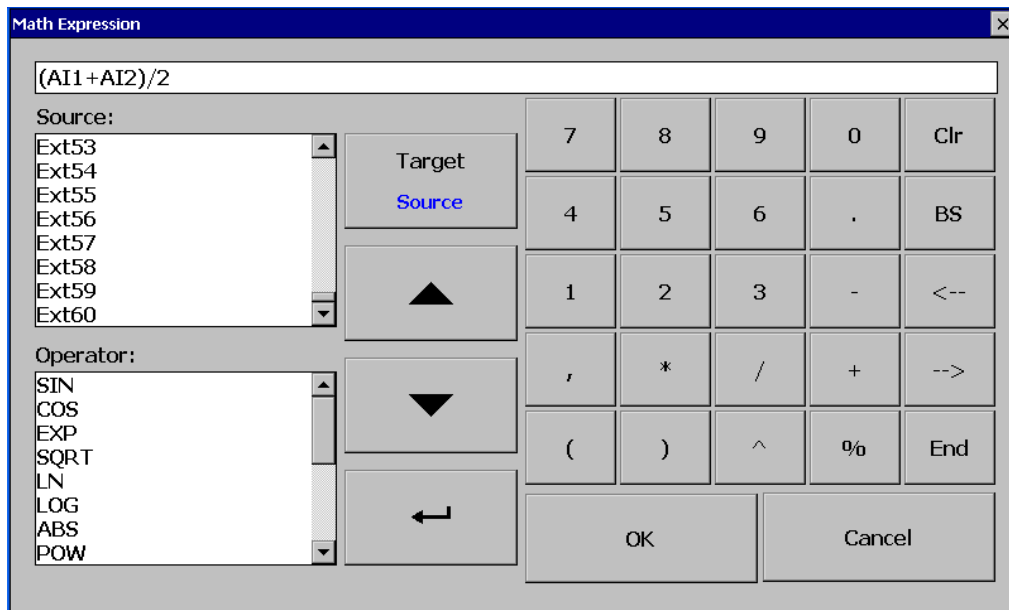
**Type:** Define either Math or Totalizer or Counter

Note: Based on selection at “Type”, configuration details will be changed. For ex:  
Type=Math have a different configuration details compared with Type = Totalizer or  
Type = Counter

**Log data type, Trigger, Method, Speed:** Same as Analog Input

WHess **Back** key and then WHess “**Home**” soft button go to Real time display and memorize the Math settings.

Enter ExWHession column, it appears Source, Operator and a keyboard.



The Source covers all available Analog inputs, Digital Inputs, Math inputs, external channels.

The Operators are Mathematics expressions described below.

Use Source, Operator and keyboard to define the Math equation.

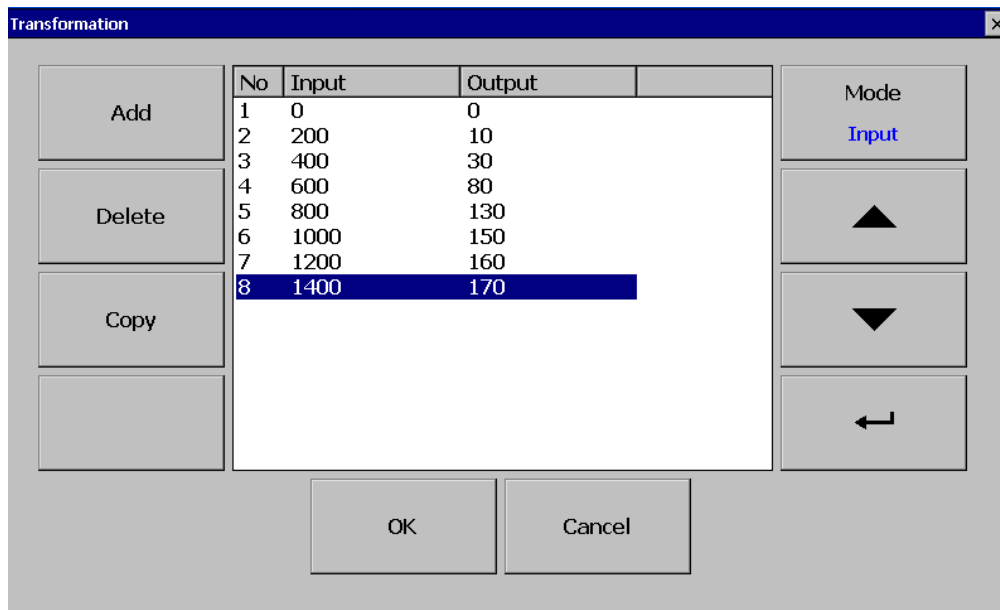
Scale  
 Unit: Tons  
 Transformation: Value  
 Table: Point 1 to 8  
 Range: 0 ~ 170

**Transformation:** Select disable, value or Math channel. This function mainly used to display WHocess values obtained from Non-linearization table

**Table:** Select disable, value or Math channel

Maximum 64 rows can be entered in the Transformation table

Ex: A chemical tank is with non-linear shape. Level is 0 to 1400 cms. The Recorder should display 0 to 170 Tons as per following table



Add: WHess "Add" soft button to add a new row into the Transformation table

Delete: WHess "Delete" soft button to delete existing row from the Transformation table

Copy: "WHess" to copy existing row in the Transformation table to create a duplicate entry

Mode: WHess to toggle between Input and Output entries in the Transformation table

Up & Down: To navigate among rows in the Transformation table

### 4.1.3.1 Math ExWHession

ExWHessions	Mathematics Functions
+	Addition
-	Subtraction
*	Multiplication
/	Division
SIN(x)	$\sin(x)$
COS(x)	$\cos(x)$
EXP(x)	$e^x$
SQRT(x)	Square root of x
LN(x)	$\log_e(x)$
LOG(x)	$\log_{10}(x)$
ABS(x)	Absolute of x
POW (x,y)	$x^y$
ROUND(x)	The closest integral number to x
HI(x,y)	The bigger value between x and y
INV(x)	$1/x$
TG(x)	$\tan(x)$
CTG(x)	$1/\tan(x)$
ASIN(x)	$\sin^{-1}(x)$
ACOS(x)	$\cos^{-1}(x)$
ATG(x)	$\tan^{-1}(x)$
x%y	Remainder of x/y
x^y	$x^y$

### 4.1.3.2 Math Example-1

#### Relative Humidity – WH20 Math application

/\*How to Calculate Relative Humidity - Theory

Requirement: Two Analog Inputs, Type: RTD

AI1: To measure dry bulb temperature

AI2: To measure wet bulb temperature

First calculate the saturation vapor WHessure (E) for both the dry-bulb (Td) and wet-bulb (Tw) temperatures using the following equations:

$$E_w = 0.61078 * \text{EXP}((17.269 * T_w) / (T_w + 237.3)) * (T_d - T_w)$$

$$E_d = 0.61078 * \text{EXP}((17.269 * T_d) / (T_d + 237.3)) * (T_d - T_w)$$

In the above equations the temperatures units are Celsius and the saturation vapor WHessure units are millibars. The function "EXP" is the exponential and not raising something to an exponent.

Then calculate actual vapor WHessure (Ea) using the following equation:

$$E_a = E_w - 0.63 * (T_d - T_w)$$

Relative Humidity is then calculated using the following equation:

$$RH = (E_a / E_d) * 100$$

The units of relative humidity are in percent.

Here is an example of the using the equations:

Assume that your dry-bulb temperature (Td) = 40 C and your wet-bulb temperature (Tw) = 30 C.

$$E_w = 0.61078 * \text{EXP}((17.269 * T_w) / (T_w + 237.3)) * (T_d - T_w)$$

$$E_w = 0.61078 * \text{EXP}((17.269 * 30) / (30 + 237.3)) * (40 - 30)$$

$$E_w = 42.4262 \text{ millibars}$$

$$E_d = 0.61078 * \text{EXP}((17.269 * T_d) / (T_d + 237.3)) * (T_d - T_w)$$

$$E_d = 0.61078 * \text{EXP}((17.269 * 40) / (40 + 237.3)) * (40 - 30)$$

$$E_d = 73.7416 \text{ millibars}$$

$$E_a = E_w - 0.63 * (T_d - T_w)$$

$$E_a = 42.4262 - 0.63 * (40 - 30)$$

$$E_a = 36.1262 \text{ millibars}$$

$$RH = (E_a / E_d) * 100$$

$$RH = (36.1262 / 73.7416) * 100$$

$$RH = 48.99 \%$$

\*/ End of Theory

5 Math channels are required to calculate one RH.

Td = AI1, analog input for dry bulb temperature (PT100)

Tw = AI2, analog input for wet bulb temperature (PT100)

Math1 = EXP((17.269\*AI1)/(AI1+237.3))

Math2 = Ed1 = 0.61078\*Math1\*(AI1-AI2)

Math3 = EXP((17.269\*AI2)/(AI2+237.3))

Math4 = Ew1 = 0.61078\*Math3\*(AI1-AI2)

Ea = Ew - 0.63 \* (Td - Tw)

Math5= RH1 = ((Math4-0.63\*(AI1-AI2))/Math2)\*100

Name: Math1  
Desc: Math Channel 1  
Type: Expression  
Log  
Expression: EXP((17.269\*AI1)/(AI1+237.3))

Name: Math1  
Desc:  
Type: Math  
Log  
DataType: 4 Byte  
Value Range: -3.4E+38 ~ 3.4E+38  
Trigger: by Time  
Method: Instant  
Speed: 1 Sec/Dot  
Expression: EXP((17.269\*AI1)/(AI1+273.3))

Name: Math2  
Desc:  
Type: Math  
Log  
DataType: 4 Byte  
Value Range: -3.4E+38 ~ 3.4E+38  
Trigger: by Time  
Method: Instant  
Speed: 1 Sec/Dot  
Expression: 0.61078\*Math1\*(AI1-AI2)

Name: Math3  
Desc:  
Type: Math  
Log  
  DataType: 4 Byte  
    Value Range: -3.4E+38 ~ 3.4E+38  
  Trigger: by Time  
  Method: Instant  
  Speed: 1 Sec/Dot  
**Expression:  $\text{EXP}((17.269 \cdot \text{AI2}) / (\text{AI2} + 273.3))$**

Name: Math4  
Desc:  
Type: Math  
Log  
  DataType: 4 Byte  
    Value Range: -3.4E+38 ~ 3.4E+38  
  Trigger: by Time  
  Method: Instant  
  Speed: 1 Sec/Dot  
**Expression:  $0.61078 \cdot \text{Math3} \cdot (\text{AI1} - \text{AI2})$**


Name: Math5  
Desc:  
Type: Math  
Log  
  DataType: 4 Byte  
    Value Range: -3.4E+38 ~ 3.4E+38  
  Trigger: by Time  
  Method: Instant  
  Speed: 1 Sec/Dot  
**Expression:  $((\text{Math4} - 0.63 \cdot (\text{AI1} - \text{AI2})) / \text{Math2}) \cdot 100$**

Now, in Math5, you will get Relative humidity in %

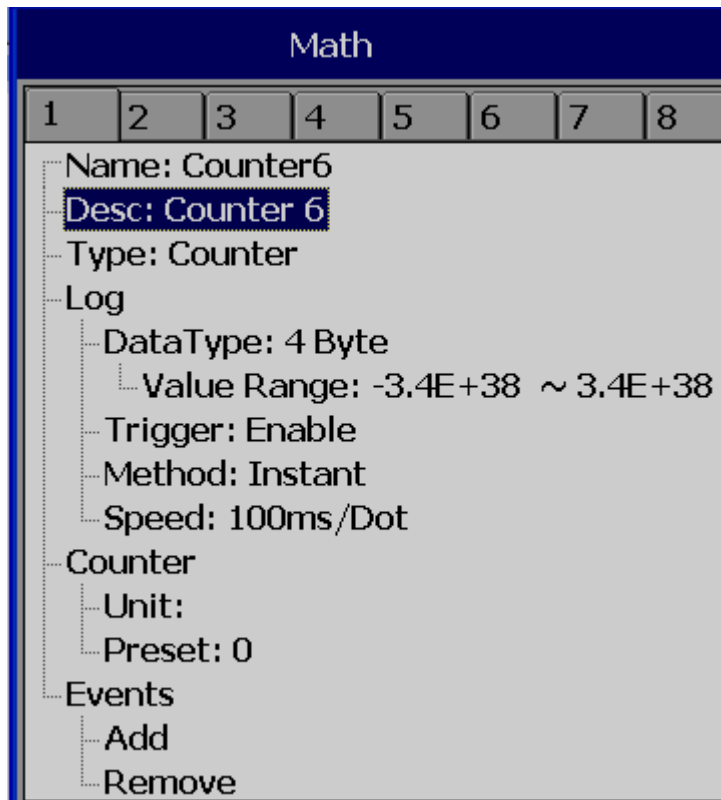
Five events are supported for every Math channel and two jobs are available in every event same as Analog input channel.

Math channels are virtual channels. It contains measured value based on the equations. These values can be recorded similar to physically connected Analog inputs and display digital values, trends, bar graphs etc.

### 4.1.3.3 Counter

Path:  (Menu)-More-Config/Math

Select **Type = Counter**



WHess directional keys  $\langle \rangle$  at the bottom to select one of the Math channel for the Counter operation.

**Name:** Defines the name of counter, max. 18 characters allowed

**Desc:** Defines the description for a specific counter on the display

**Type:** Select **Counter**

#### Counter

**Unit:** Defines the unit of counter

**WHeset:** Defines the WHeset value for the counter.

**Event:** Defines the type, Set point, Log, Job1 or Job2 & Hysteresis

**Type:** Select one of the options: H, L, HH, LL, Dev+, Dev-, Error

**Set point:** Defines the set point trigger of Counter value to initiate Jobs and/or Log alarms

**Log:** Select one of Log Alarm, Log Alarm (Auto Ack.), Log Event

**Job1, Job2:** various jobs can be assigned, 2 jobs for each counter

**Hysteresis:** To avoid jobs have been activated too often, it can set for no reaction.

Hysteresis value can be defined for the event trigger set point

#### 4.1.3.4 Counter Example-1

Operator wish to know the number of occurrence of an event in a day say WHessure switch signal high

Digital input1 is used for WHessure switch. High signal indicates High WHessure, Low signal indicates normal WHessure

The screenshot displays two configuration panels. The top panel is titled 'DI' and contains a table with two columns labeled '1' and '2'. Below the table, the configuration for 'DI1' is shown, including a description 'Pressure Switch' and an event configuration with 'Type: H', 'Log: No Action', 'Job1: Inc Counter\_Counter1', and 'Job2: No Action'. The bottom panel is titled 'Timer' and contains a table with seven columns labeled '1' through '7'. Below the table, the configuration for a timer is shown, including 'Type: Daily', 'Action: Enable', 'Time' settings (Hour: 23, Min: 59, Sec: 1), and 'Job1: Log Report\_Counter1' and 'Job2: Reset Counter\_Counter1'.

DI	
1	2
Name: DI1	
Desc: Pressure Switch	
Events	
Add	
Remove	
1	
Type: H	
Log: No Action	
Job1: Inc Counter_Counter1	
Job2: No Action	

Timer						
1	2	3	4	5	6	7
Type: Daily						
Action: Enable						
Time						
Hour: 23						
Min: 59						
Sec: 1						
Job1: Log Report_Counter1						
Job2: Reset Counter_Counter1						

(Reset Counter1 historical data in order to log new data for the next day)

Archive historical data by WHessing the following.

 (Menu)-Event-Report, Select Daily in the Mode

If values meet the following conditions, paperless recorder will change notation from traditional to scientific

- a. the value is more than  $10^5$  or less than  $1/(10^5)$
- b. the value digit-length in display exceeds the allowed range

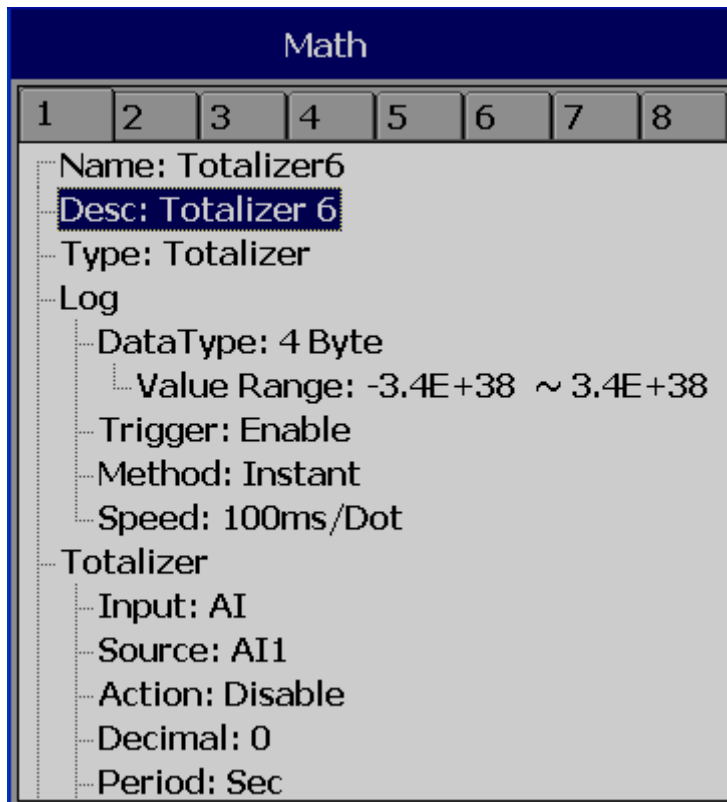
Ex: Up to 5 digits, counter displays value directly Say 0-99999.  
100000 will be shown as 1E5 that means 5 zero's after 1  
4294967295 will be shown as 4.29497E9 etc.

#### 4.1.3.5 Totalizer

In New generation Recorder, Totalizer is a part of Math channel.

Configuration Path:  (Menu)-More-Config-Math

Select **Type = Totalizer**



WHess directional keys ( < > ) at the bottom to select from available Totalizers

**Name:** Defines the name of the Totalizer, Maximum 18 characters allowed

**Desc:** Defines the description for a specific Totalizer on the display

**Type:** Select "Totalizer"

**Log:** Same as Analog input configuration

**Totalizer:**

**Input:** Analog Input (AI) or Pulse Counter (DI)

**Source:** Select the source for the Totalizer from Analog input/Math/Counter/Totalizer

**Action:** Disables or enables the Totalizer

Math					
1	2	3	4	5	6
Method: Instant					
Speed: 100ms/Dot					
<b>Totalizer</b>					
Input: AI					
Source: AI1					
Action: Disable					
Decimal: 0					
Period: Sec					
Unit:					
Preset: 0					
Low Cut: 0					

**Decimal:** Defines the decimal point for the Totalizer

**Period:** Selects second, minute or hour used for the Totalizer

**Unit:** Defines the unit of totalizing

**WHeset:** Defines the WHeset value for the Totalizer.

**Low Cut:** Defines the Low Cut for the Totalizer.

For ex: If 0.0 is set as Low cut, then, if source channel, AI1 is less than 0.0, then, Totalizer value will not go to negative.

**Event:** Total 5 events are supported for each Math channel. Defines the type, Set point,

Log, Job1 or Job2 & Hysteresis

**Type:** Select one of options, H, L, HH, LL, Dev+, Dev-, Error

**Set point:** Defines the set point trigger of Totalizer value to initiate Jobs and/or Log alarms

**Log:** Select one of Log Alarm, Log Alarm (Auto Ack.), Log Event

**Job1, Job2:** various jobs can be configured, 2 jobs for each Totalizer

**Hysteresis:** To avoid jobs have been activated too often, it can set for no reaction. Hysteresis value can be defined for the event trigger set point

#### 4.1.3.6 Totalizer Example-1

Water flow rate is in M<sup>3</sup>/Sec. Operator want to know about total water discharged and want this information daily, weekly and monthly reports

Name: Totalizer1  
Desc:  
Type: Totalizer  
Log  
  DataType: 4 Byte  
    Value Range: -3.4E+38 ~ 3.4E+38  
  Method: Instant  
  Speed: 1 Sec/Dot

Timer						
1	2	3	4	5	6	7
Type: Daily						
Action: Enable						
Time						
Hour: 23						
Min: 59						
Sec: 1						
Job1: Log Report_Totalizer1						
Job2: Reset Totalizer_Totalizer1						

Reset Totalizer1 historical data in order to log new data for the next day

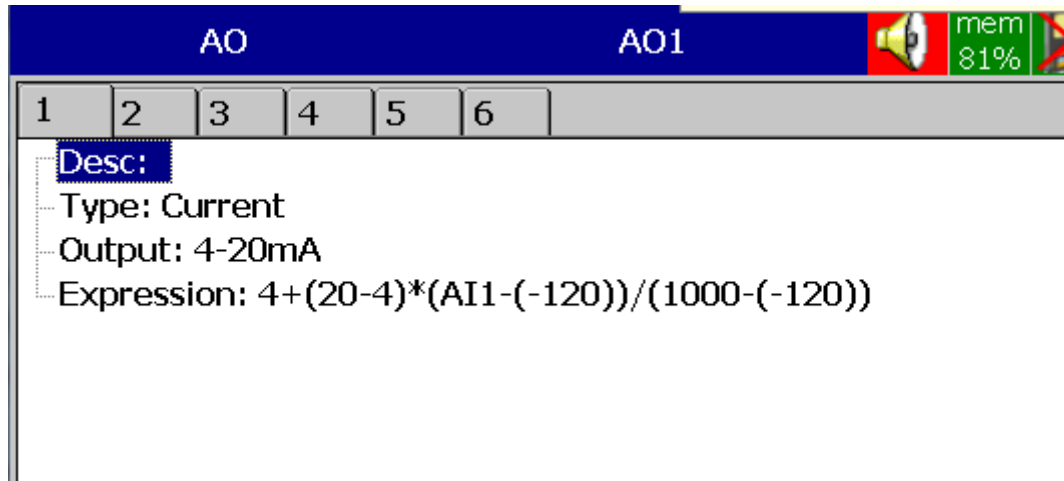
Archive historical data by WHessing the following.

Path:  (Menu)-Event-Report

Select **Daily** in the **Mode** to see reports on day basis, to navigate for other day, WHess on Left and right arrows below the **Mode** button. Select **Weekly** in the **Mode** to see weekly reports and **Monthly** on the **Mode** to see Monthly reports.

#### 4.1.4 Analog Output

After entering the Configuration, in the Channel, select AO, then WHess the “Enter” soft button to get into Analog Output Channel configuration page.



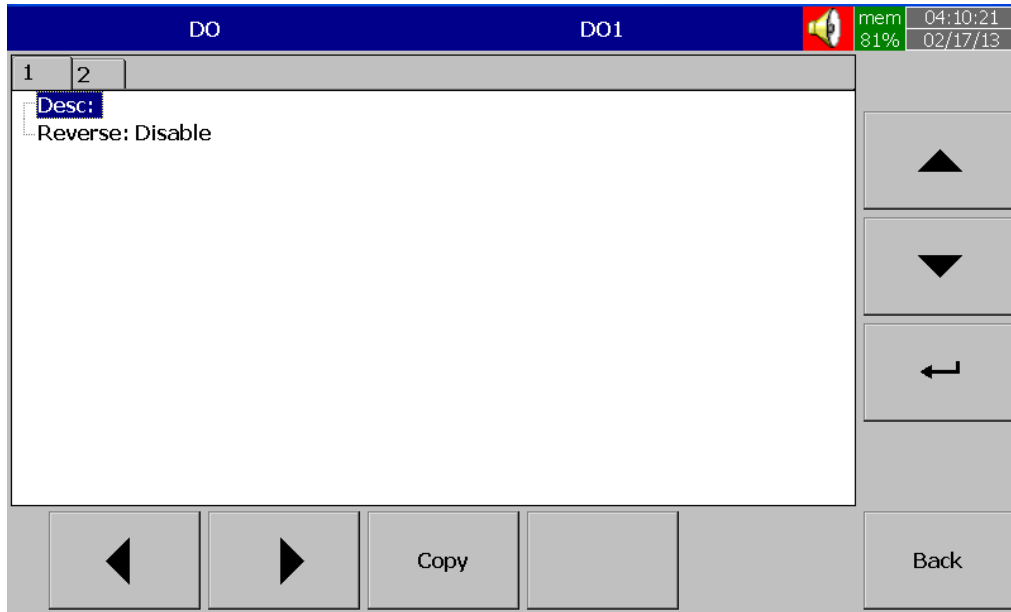
**Desc:** Define detail description for the channel name

**Type:** Current, Voltage

**Output:** Select either disable, 0 to 20 ma , 4-20 mA,0-5V, 1-5V, 0-10VDC

**ExWHession:** This is similar to Math channel.

## 4.1.5 Digital Output



**Desc:** Define detail description for the channel name

**Reverse:** Enable this if Reverse operation required for the Digital Output.

For ex: Normally, Relay output is Normally Open (NO). In case if you need to get Normally Close (NC) at Recorder Power ON, then, enable Reverse for selected Digital Output. The operation is Relay output shall be reversed

## 4.1.6 External

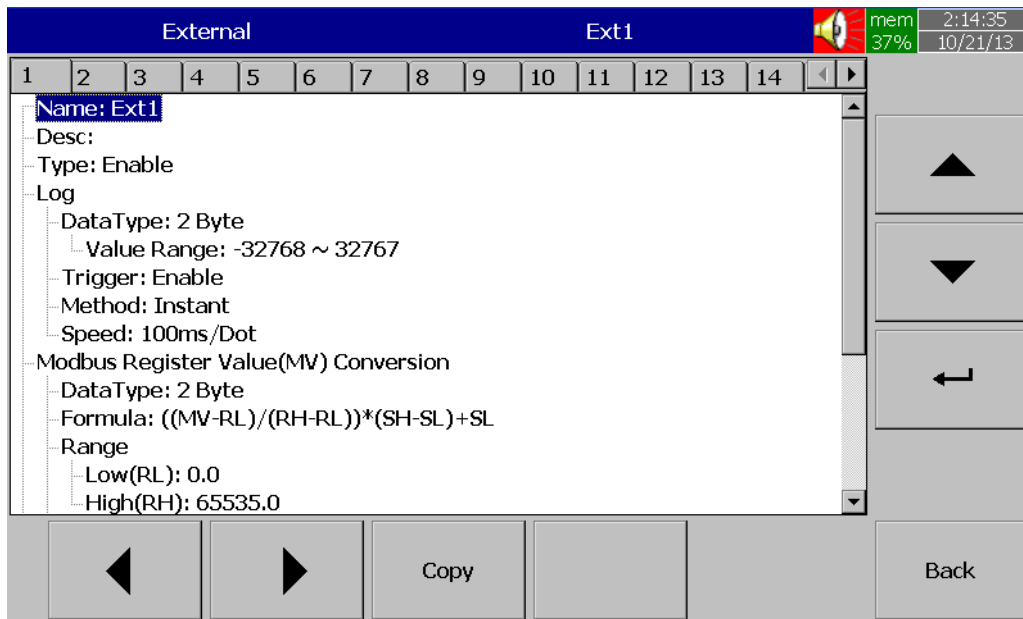
This is to access data from the external devices.

Maximum no. of external channels in various WH series Recorders are as follows

WH Recorder	WH-10	WH-20	WH-30
Maximum External Channels	24	48	96

All the WHoperties are similar to Analog Input channel.

More details about external channels are available at section “Communication”



Please refer section “Communication” for examples of external channels

#### 4.1.7 Jobs

Various types of jobs can be selected as follows.

**No Action:** Do nothing

**Send Email:** Send Email directly from Recorder

**Pause:** Stop logging data.

**Start:** Start logging data.

**Sound Buzzer:** Sound the buzzer. It stops once any key is WHessed.

**Dump Data:** To dump data from internal memory to external memory.

**DO Latch On:** Set digital output / relay on, and then select Target, say from one of DO 1 to DO 6. The relay is latched when it is activated.

**DO Latch Off:** Set digital output / relay off, and then select Target say, from one of DO 1 to DO 6. The relay is latched when it is activated.

**DO WHocess:** Set digital output / relay on for WHocess high or low, and then select Target

Say, from 1 of DO 1 to DO 6. The relay is not going to be latched when it is activated.

**Enable Timer:** Start the timer, and then select Target timers

**Disable Timer:** Stop the timer, and then select Target from Timers

**WHeset Totalizer:** set a WHeset value to the target Totalizer.

**Reset Totalizer:** Reset Totalizer into zero, and then select Target Totalizer or All totalizers

**Enable Totalizer:** Start the Totalizer, then select Target Totalizer or All totalizers

**Disable Totalizer:** Stop the Totalizer, then select Target Totalizer or All totalizers

**WHeset Counter:** set a WHeset value to the target counter.

**Reset Counter:** Resets the counter into zero, and then select Target counter or All counters

**Inc Counter:** Increase 1 to the counter, and then select Target counter or All counters

**Dec Counter:** Decrease 1 from the counter, and then select Target counter or All counters

**Log Report:** Make the report for Counter, Totalizer, Analog inputs Min/Max/Avg, Math Min/Max/Avg, All Counters, All Totalizers, All Channels Min/Max/Avg. Choose this column, and then the report will be WHesented as details described in section “**Reports**”

**Reset MinMaxAve:** In Report function, after logging the MinMaxAve data of AI and Math channels for one day for example, then reset historical data in order to logging new data for the next day. It is also possible to reset MinMaxAve for “All Channels” at one step.

**WHint:** If WHinter is connected to Paperless Recorder via USB port or Ethernet, then, the following WHint jobs can be triggered from the events


WHint Historical data

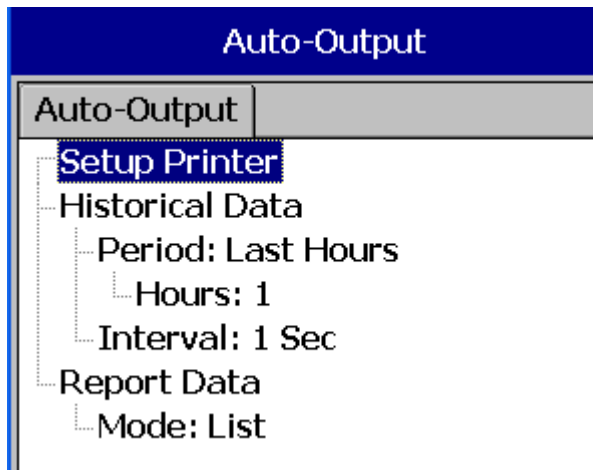
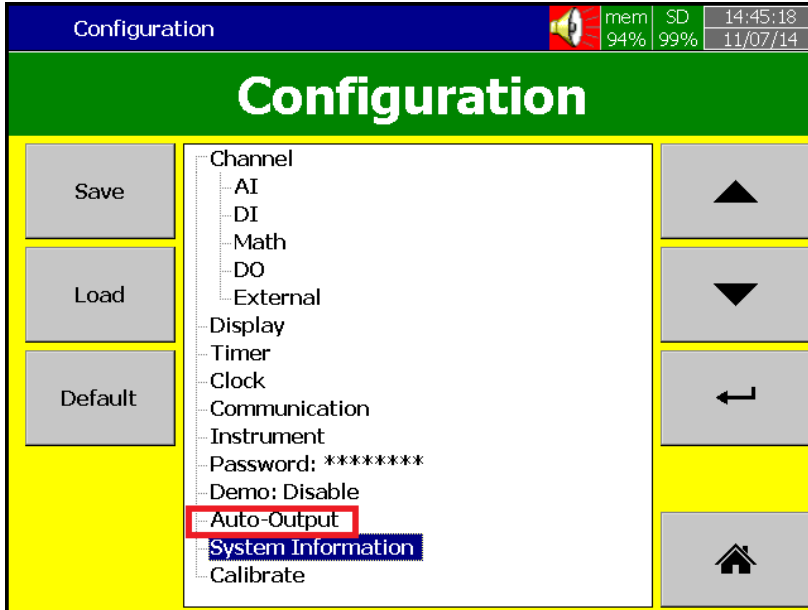
WHint Event List

WHint Report List

WHint Snapshot

The time period and internal depends on default configuration available at

 (Menu)-More-Config-Auto-Output



Note: Please refer section "Auto Output" for more details about options available

**Note:**


- ◆ In the mode the sampling rate of the recorder is fixed at 100 milli seconds by the hardware, i.e. 10 samples are collected per second. If the logging speed is set at 1 second in Instant mode, the recorder logs using the last of ten measured data values. For the same speed in Average mode, the recorder logs using the average of the Ten measured data values. For the same speed in the Maximum or Minimum mode, then the recorder logs using the maximum or minimum of the Ten measured data values.

	<b>Sampling</b>	<b>Logging (historical trend)</b>	<b>Display (real time)</b>
Instant	100mS	the last of 10 measured data	the last of 10 measured data
Averaged	100mS	the average of 10 measured data	the last of 10 measured data
Maximum	100mS	the maximum of 10 measured data	the last of 10 measured data
Minimum	100mS	the minimum of 10 measured data	the last of 10 measured data

WHess “**Home**” key to return to real-time display, all configurations will be memorized

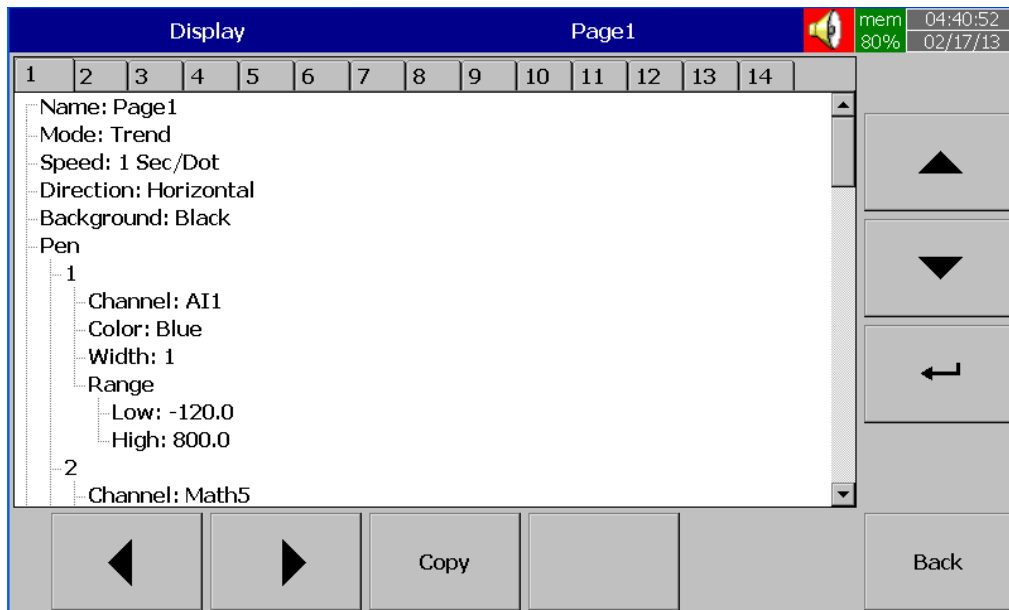
- ◆ The Digital output DO card with relay can be set in Job1, Job2. It can be traced in System Info mode after installed into the Slot.

## 4.2 Display

Path:  (Menu)-More-Config-Display

Select “**Display**” and WHess “**Enter**” Soft button to get into Display mode configuration page.

	WH10	WH20	WH30
Display pages	8	20	21
Pens/Page	6	6	10



**Name:** Defines the name of the display page

**Mode:** Defines the default method of displaying data for the page. Options are: Trend, Bar, Digital, Mix and Disable modes.

**Speed:** This is display speed. Available options are 100 msec/dot, 1 Sec/dot, 2 Sec/dot, 5 Sec/dot, 10 Sec/dot, 20 Sec/dot, 30 Sec/dot, 1 min/dot, 5 min/dot, 10 min/Page, 30 min/Page, 1 hour/Page, 2 hour/Page, 4 hour/Page, 8 hour/Page, 12 hour/Page and 1 Day/Page.

**Direction:** Selects the trend direction horizontal or vertical.

**Background:** Defines the background color of Trend mode in black or white

**Pen:** Defines a specific channel as a drawing pen, its color, width, Range Low and Range High for the display.

**Channel:** Selects a specific analog input, Math, Counter, Totalizer, External channels. Select Disable if a specific channel is not required to be displayed.

**Color:** Selects the color for each pen.

**Width:** Selects the width of trend, 1-thin, 2-medium, 3-wide.

**Low:** Defines the low scale for a pen on the display.

**High:** Defines the high scale for a pen on the display.

**Note:**

- ◆ To illustrate the difference between Display Hi, Display Lo and Scale Hi, Scale Low. Here is a typical example, with input 0-10V, Scale Low=0.00, Scale Hi=100.00, to have better resolution and vision on Bar, set Display Lo=0.00, Display Hi=50.00 so that the Bar displays from value 0.00 to 50.00.
- ◆ The decimal point is defined by Scale Hi and Scale Low, and not by Display Hi, or Display Lo.

### 4.2.1 Status Bar

**Status Bar:** To make it convenient when viewing the status of Digital Input, Digital Output, Math channel, Totalizer, Counter and AO, the user may enable these items in the status bar. Status bar shall be displayed at Lower part of the page. Maximum 10 tags can be displayed in each Status bar. One status bar can be configured for each page.

**Note:** Status bar configuration is not common for all the pages. You may define different setup for status bar in different pages as per your requirements.

#### Status Bar

Type: Enable

1: DI1

2: DI2

3: DO1

4: DO2

5: Math1

6: Counter1

7: Totalizer1

8: AO1

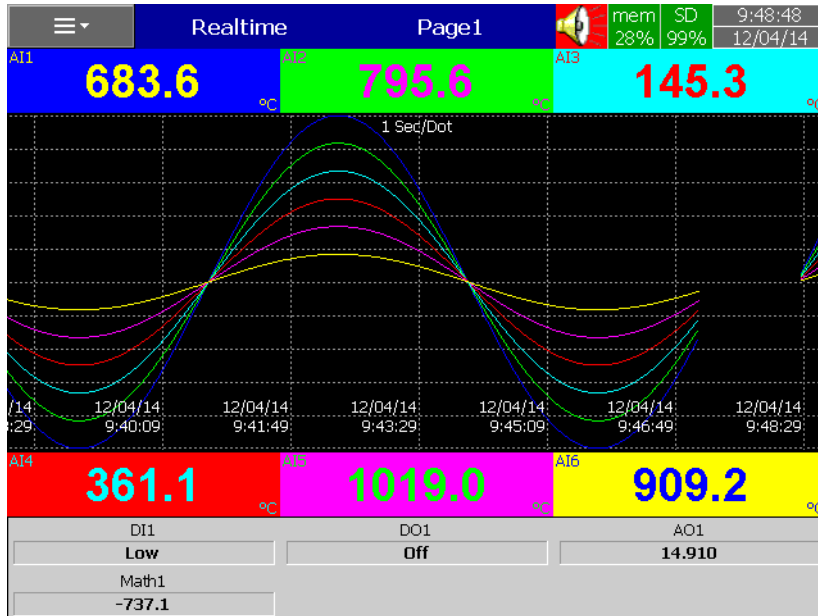



Fig: Status bar display in Real time

### 4.3 Timer

Path:  (Menu)-More-Config-Timer

The screenshot shows the 'Timer' configuration interface. The title bar indicates 'Timer Timer1' and shows system metrics: 'mem 30%' (green) and a timestamp '05:01:44 02/17/13'. A row of 14 numbered buttons (1-14) is visible. The main area displays configuration details for a selected timer: 'Type: Daily', 'Action: Enable', 'Time: Hour: 8, Min: 1, Sec: 0', 'Job1: DO Latch On\_DO1', and 'Job2: No Action'. On the right side, there are three directional buttons: up, down, and left. At the bottom, there are four buttons: left arrow, right arrow, 'Copy', and 'Back'.

WHess directional keys < > at the bottom to select one from 20 available timers.

**Type:** Countdown, Repeat Countdown, Daily, Weekly or Monthly.

**Countdown:** Defines the interval of time, e.g. days, hours, minutes and seconds.

(Not Real Time)

**Repeat Countdown:** Repeats the WHevious countdown. (Not Real Time)

**Daily, Weekly or Monthly:** The timer works in selected interval of Real Time.

**Action:** Disables or enables the timer.

**Job1, Job2:** 2 jobs can be configured for each timer.

#### 4.3.1.1 Timer Example-1

Switch on water pump every day at 8.00 hrs and switch off at 10.00 hrs

This application requires to Daily type timer which works with Real Time Clock.

Configuration settings are as follows.

##### Timer1

Type: Daily      Action: Enable  
Time – Hour: 8    Min: 0    Sec: 0  
Job1: DO Latch On, Target: DO1  
Job2: No Action

##### Timer2

Type: Daily      Action: Enable  
Time – Hour: 10   Min: 0    Sec: 0  
Job1: DO Latch Off, Target: DO1  
Job2: No Action

#### 4.3.1.2 Timer Example-2

Once digital input high event is triggered say WHessure high, you would like switch on relay after a delay of 10 sec

##### Digital Input1

Event1  
Type: H  
Job1: Enable Timer, Target: Timer1  
Job2: No Action

Event2  
Type: L  
Job1: DO Latch Off, Target: DO1  
Job2: No Action

##### Timer1

Type: Countdown, Action: Disable  
Time – Hour: 0 Min: 0 Sec: 10  
Job1: DO Latch On, Target: DO1  
Job2: No Action

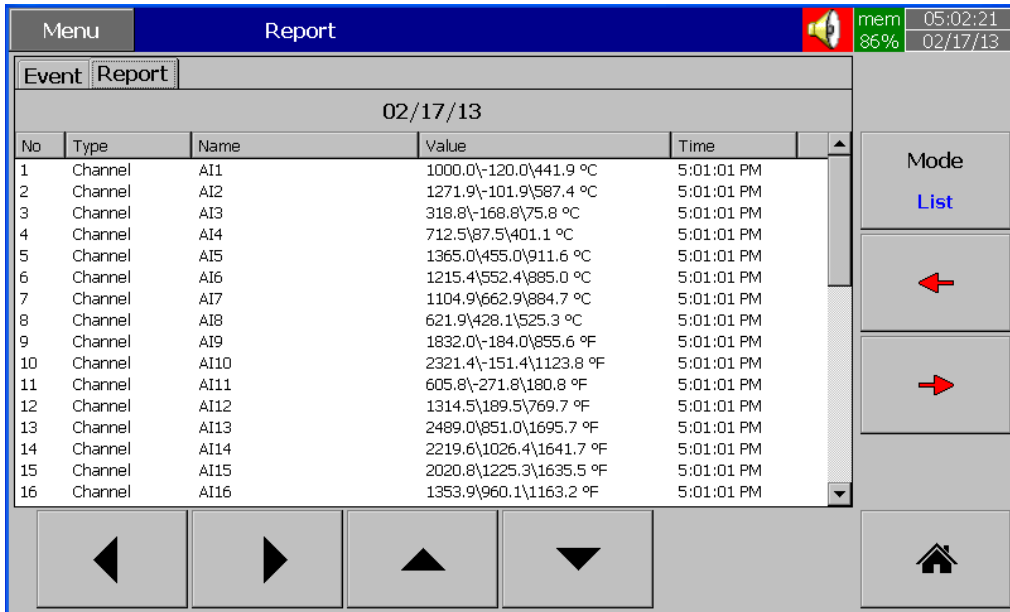
#### 4.3.1.3 Timer Example-3

Timer & Report:


**A staff plans to get a daily report from the recorder about the minimum, maximum and average values of the WHocess every day. After the WHoduction has finished, he can WHess Menu, then Event, select Report and WHess Mode key to select Daily mode and get the report like figure shown below**

##### Timer1

Type: Daily            Action: Enable  
Time – Hour: 17            Min: 01  
Job1: Log Report            Target: ALL CH MinMaxAve  
Job2: Reset MinMaxAve Target: ALL CH  
(Reset historical data in order to logging new data for the next day.)



#### 4.4 Clock

Path:  (Menu)-More-Config-Clock

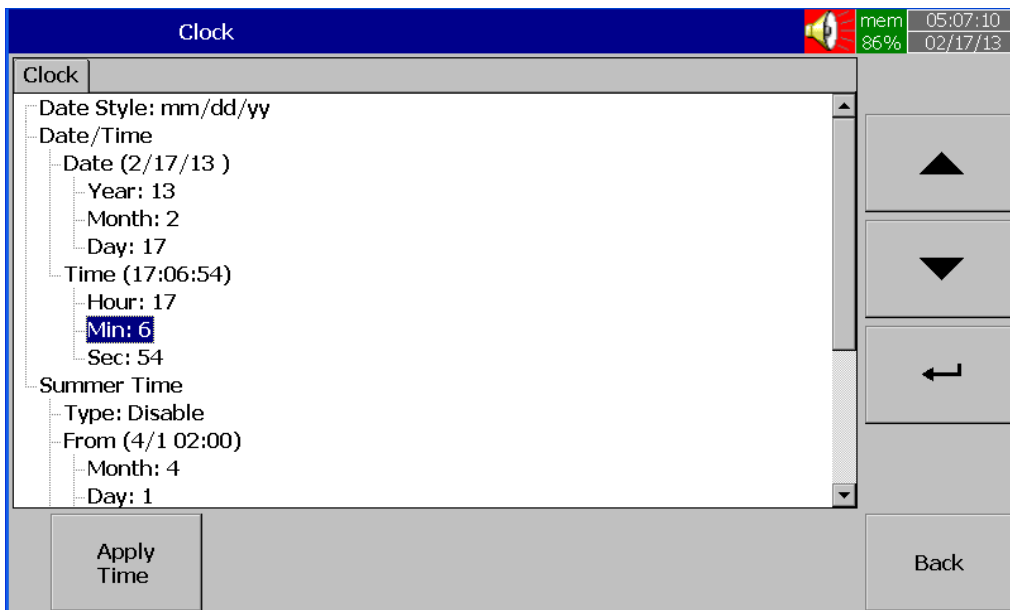


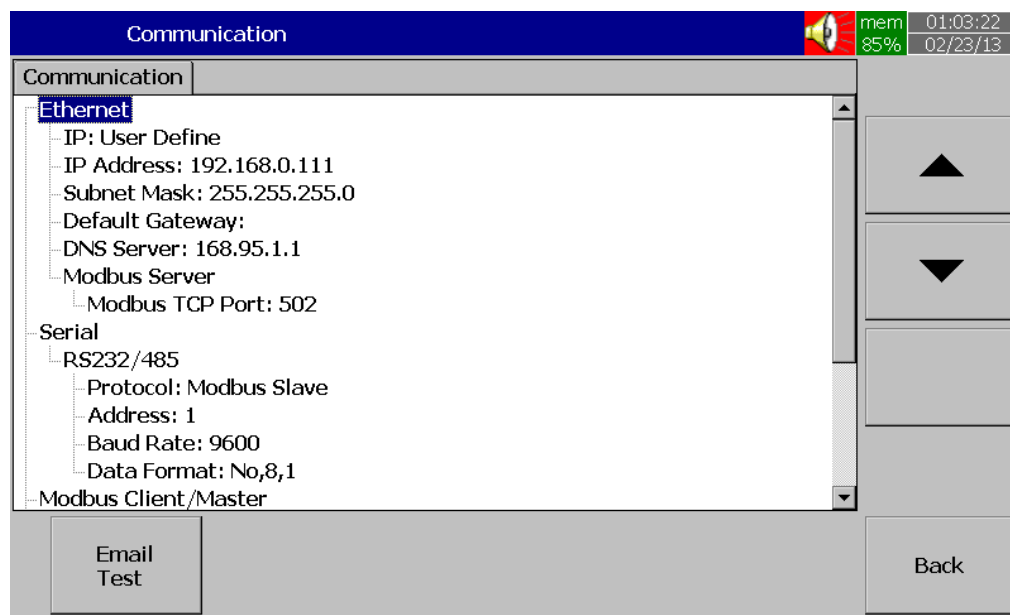
Fig: Clock configuration page in Paperless Recorder

**Date Style:** Selects either month/date/year or date/month/year

**Date/Time:** Set up the local time. Use directional keys Up/Down to select the column, WHess “Enter” soft button to change the clock data. Then WHess on “Apply Time” Soft button to apply it to the recorder.

**Summer time:** In some countries of North America and Europe, clocks are adjusted forward one hour near the start of sWHing and are adjusted backward in autumn for energy saving purpose because of change in day light conditions. Summer time set WHovision is available in paperless recorder. In Summer time, Select Type: Enable and then set Start (Month, Day, Hour, Min) and End (Month, Day, Hour, Min) details.

## 4.5 Communication



### Ethernet

**IP:** Automation/User define

Select **Automation** if the server on the network automatically allocates the IP address for the recorder.

Select **User Define** to manually set a fixed address for the recorder.

**IP Address:** Defines the correct address of the recorder on the network

**Subnet Mask:** Defines the correct **Subnet Mask** address on the network

**Default Gateway:** Define Gateway address.

**DNS Server:** This is required if recorder is to be connected to Internet

**Modbus Server:**

**Modbus TCP Port:** Default: 502 for Modbus TCP

**Serial:**

**Protocol:** Modbus RTU Master/ Modbus RTU Slave

**Address:** Address of Master/Slave in the network

**Baud rate:** 9600/14400/19200/38400/57600/115200

**Data format:** None, 8, 1 or Odd,8,1 or Even, 8, 1

**Modbus Client/Master:**

**Sample Rate:**

Ethernet: 100 msec/dot, 1 sec/dot, 2 sec/Dot, 5 sec/dot, 10 sec/dot

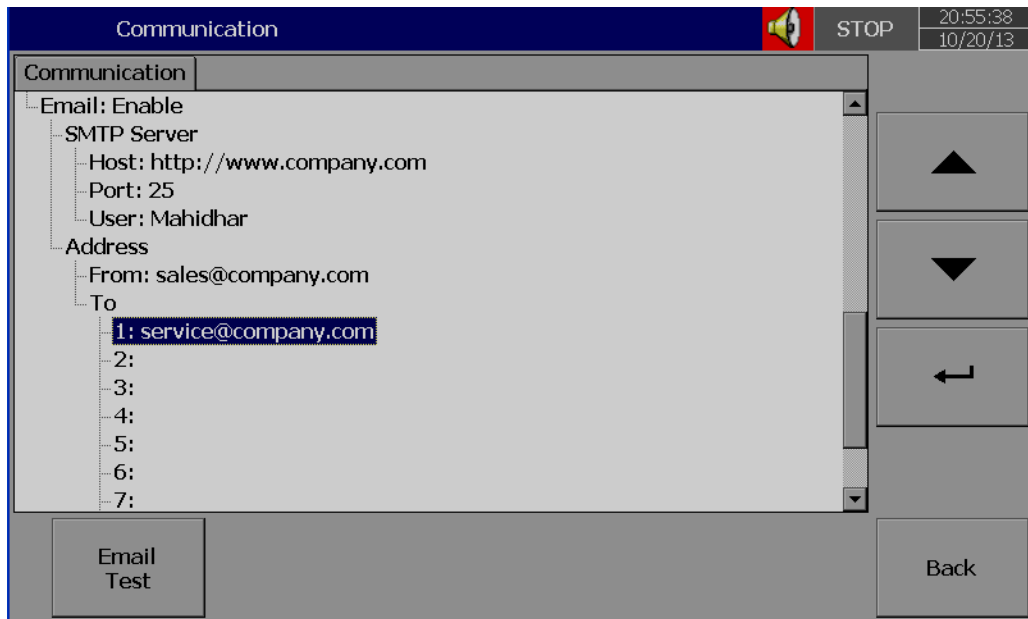
Timeout : The default timeout is 100ms

Serial: 100 msec/dot, 1 sec/dot, 2 sec/Dot, 5 sec/dot, 10 sec/dot

Timeout : The default timeout is 100ms

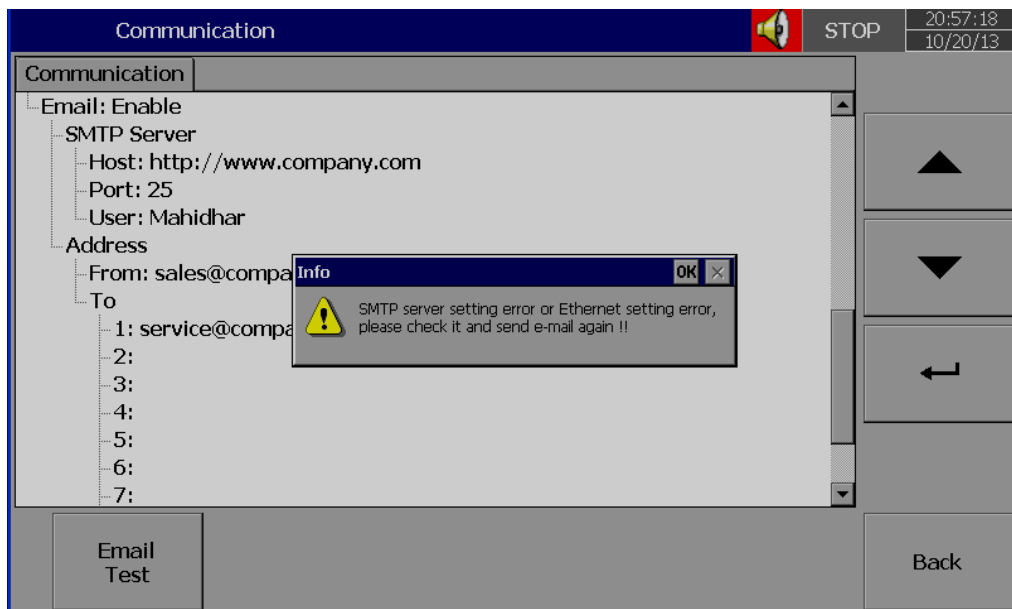
Interval between 2 commands : The default timeout is 10ms

**Email:** Enable/Disable



WHess' "Email Test" and check mail function

If any WHoblems with Email delivery, it will show error as shown attached



### 4.5.1 Connections

Total 16 connections are available

Each connection can be configured as either Serial or Ethernet

Connections					
1	2	3	4	5	6
Name: Connect1					
Type: Serial					
Slave ID: 1					

**Name:** Connection name

**Type:** Serial/Ethernet

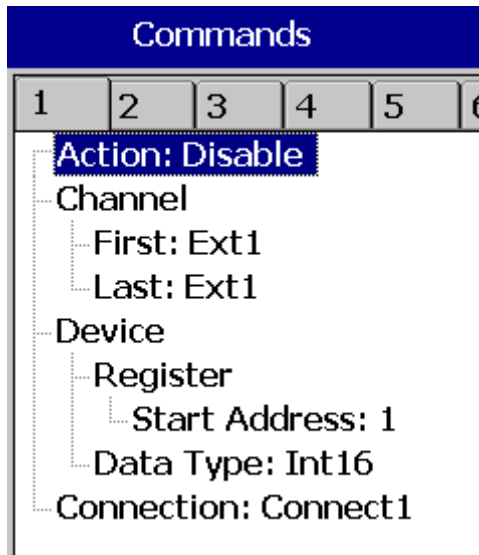
**Slave ID:** If Recorder is Modbus RTU Master, then, all the Slaves need to be configured in the connections.

Connections				
1	2	3	4	5
Name: Connect2				
Type: Ethernet				
IP: 192.168.0.1				
Port: 502				
Slave ID: 1				

**IP:** This is enabled only if Type = Ethernet selected at any connection

## 4.5.2 Commands

Total 16 commands are available



**Action:** Enable/Disable

**To Channel:**

**First:** Enter first external channel details, Ex : Ext1

**Last:** Enter last external channel details, Ex: Ext24

**From Device**

**Register:**

**Start Address:** Enter Start register address

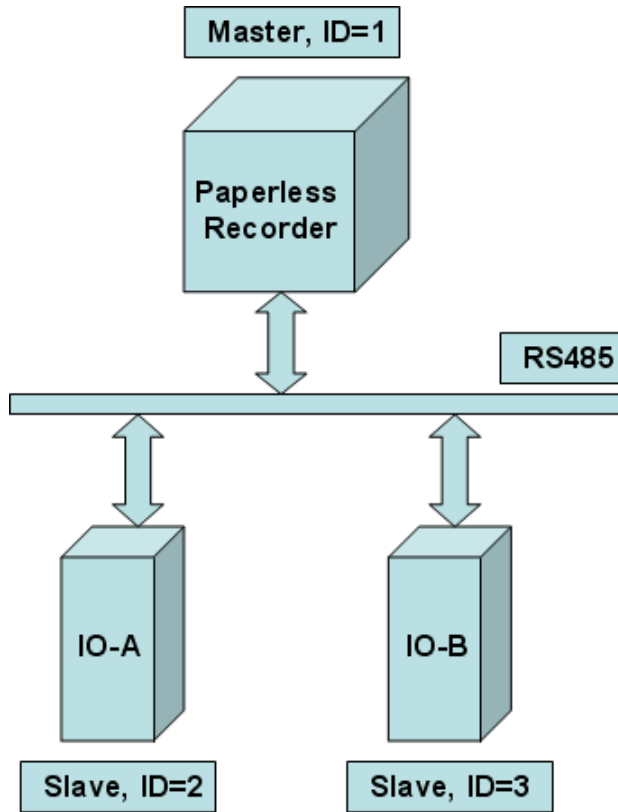
**Data Type:** Int16/UInt16/Int32\_B/Int32\_L, UInt32\_B, UInt32\_L, Float\_B, Float\_L

**Connection:** Select the required connection

### 4.5.3 Modbus RTU Master , Example1

Master: Paperless Recorder

Slaves: External IO modules, 2 nos. each with 8 channel Analog inputs



Modbus Address	Register Name	Low Limit	High Limit	Access
30002	Analog Input 1	0	4095	R
30003	Analog Input 2	0	4095	R
30004	Analog Input 3	0	4095	R
30005	Analog Input 4	0	4095	R
30006	Analog Input 5	0	4095	R
30007	Analog Input 6	0	4095	R
30008	Analog Input 7	0	4095	R
30009	Analog Input 8	0	4095	R

Fig: External IO modules Register table

## Master Configuration

### Serial

- RS232/485
  - Protocol: Modbus Master
  - Address: 1
  - Baud Rate: 38400
  - Data Format: No,8,1

## Slave Configuration

Connections					
1	2	3	4	5	6
Name: Connect1					
Type: Serial					
Slave ID: 2					

Connections					
1	2	3	4	5	6
Name: Connect2					
Type: Serial					
Slave ID: 3					

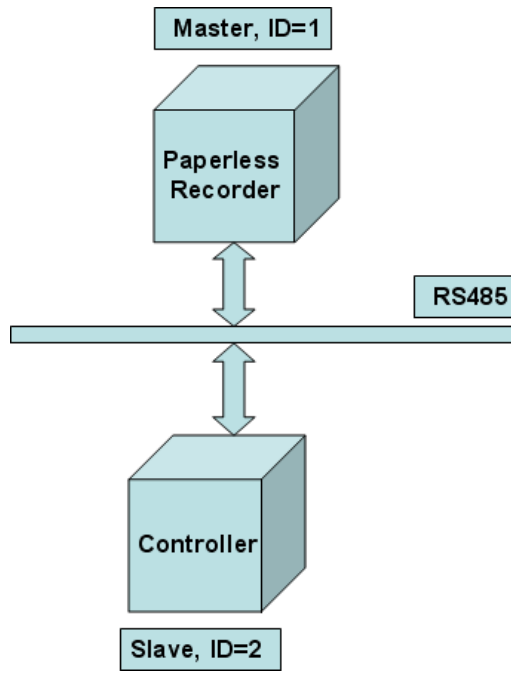
Commands					
1	2	3	4	5	6
<ul style="list-style-type: none"> <li>- Action: Enable</li> <li>- To Channel <ul style="list-style-type: none"> <li>- First: Ext1</li> <li>- Last: Ext8</li> </ul> </li> <li>- From Device <ul style="list-style-type: none"> <li>- Register <ul style="list-style-type: none"> <li>- Type: Input</li> <li>- <b>Start Address: 2</b></li> </ul> </li> <li>- Data Type: Int16</li> </ul> </li> <li>- Connection: Connect1</li> </ul>					

Commands					
1	2	3	4	5	6
<ul style="list-style-type: none"> <li>- Action: Enable</li> <li>- To Channel <ul style="list-style-type: none"> <li>- First: Ext9</li> <li>- Last: Ext16</li> </ul> </li> <li>- From Device <ul style="list-style-type: none"> <li>- Register <ul style="list-style-type: none"> <li>- Type: Input</li> <li>- Start Address: 2</li> </ul> </li> <li>- Data Type: Int16</li> </ul> </li> <li>- Connection: Connect2</li> </ul>					

#### 4.5.4 Modbus RTU Master , Example2

Master: Paperless Recorder

Slave: PID Controller



Register Address	Parameter Notation	Parameter Description	Range	Default Value	Data type
128	PV	Process value	Low: -32768 High: 32767	—	R
129	SV	Set point value for control	Low: SPLO High: SPHI	—	R

Fig: External PID Controller Register table

## Master Configuration

- Serial
  - RS232/485
    - Protocol: Modbus Master
    - Address: 1
    - Baud Rate: 9600
    - Data Format: No,8,1

## Slave Configuration

Connections					
1	2	3	4	5	6
Name: Connect1					
Type: Serial					
Slave ID: 2					

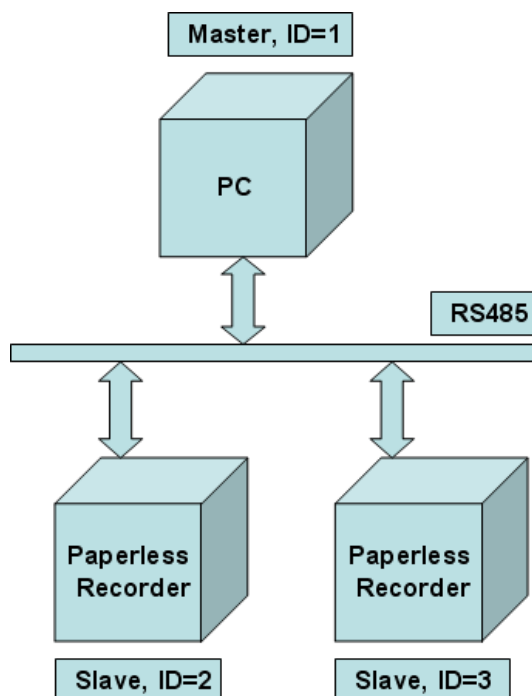
Commands						
1	2	3	4	5	6	7
Action: Enable						
To Channel						
First: Ext1						
Last: Ext2						
From Device						
Register						
Type: Input						
Start Address: 129						
Data Type: Int16						
Connection: Connect1						

External							
1	2	3	4	5	6	7	8
Name: Ext1							
Desc:							
Log							
DataType: 2 Byte							
Value Range: -32768 ~ 32767							
Trigger: by Time							
Method: Instant							
Speed: 1 Sec/Dot							
Range							
Low: -3276.8							
High: 3276.7							
Scale							
Unit:							
Low: -32768							
High: 32767							

#### 4.5.5 Modbus RTU Slave , Example

Master: PC, Modbus RTU OPC Server

Slaves: Paperless Recorders, 2 nos. each with 6 channel Analog inputs



## 1. Input Register Parameter Table

Address	Notation	Parameter	Scale Low	Scale High	Notes
0	AI1PV	AI1 process value	*1	*1	R
1	AI2PV	AI2 process value	*1	*1	R
2	AI3PV	AI3 process value	*1	*1	R
3	AI4PV	AI4 process value	*1	*1	R
4	AI5PV	AI5 process value	*1	*1	R
5	AI6PV	AI6 process value	*1	*1	R
6	AI7PV	AI7 process value	*1	*1	R

\*1: The scale high/low value are define in the following table for

Conditions	DP=0	DP=1	DP=2	DP=3	DP=4	DP=5
Scale low	-19999	-1999.9	-199.99	-19.999	-1.9999	-0.19999
Scale high	45536	4553.6	455.36	45.536	4.5536	0.45536

Fig: Paperless Recorder (Slave) Register table and Scaling information

### Serial

RS232/485

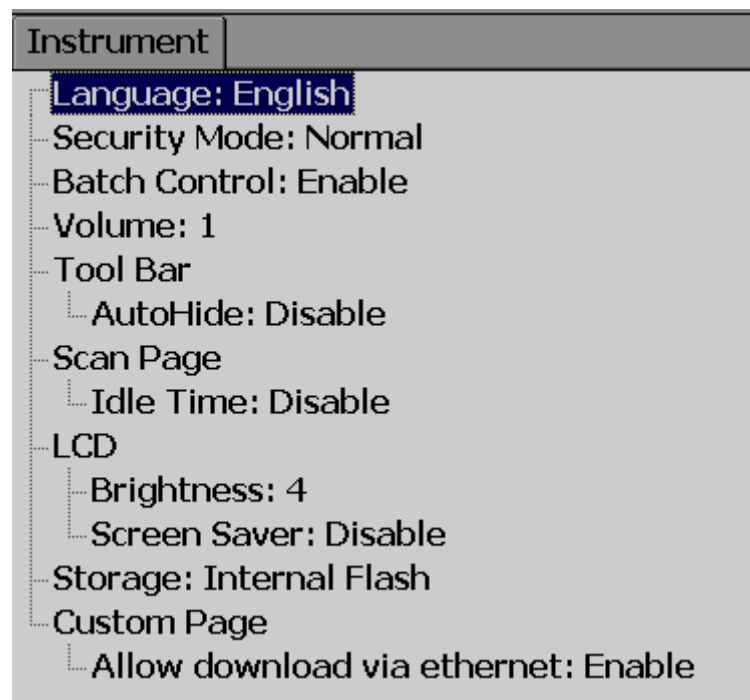
Protocol: Modbus Slave

Address: 2

Baud Rate: 38400

Data Format: No,8,1

## 4.6 Instrument



**Language:** Total 19 languages are supported. They include English, Simplified Chinese, Traditional Chinese, Japanese, Korean, French, German, Italian, Polish, Spanish, Portuguese, Brazil Portuguese, Russian, Thai, Czech, Danish, Dutch, Swedish & Turkish

**Security:** Select Normal or CFR-21 security. More details available at section “Security”

**Batch Control:** Disable and Enable options available for the selection. Refer section “Batch Control” for more details.

**Volume:** On touch, you can hear beep sound. Select Disable to switch off the beeper. Select value 1 to 10 for volume control. 1 is minimum sound and 10 for maximum sound

**Tool bar:** On left side of the display page, tool bar appears for configuration.  
Auto Hide: Select 10 Sec or 20 Sec or 30 Sec or 60 Sec to hide the tool bar if user do not operate recorder via touch screen for set time interval. Select disable if auto-hide is not required on specific set time

**Scan Page:**

**Idle time:** If touch screen is not operative for set idle time, then display pages in the recorder start scrolling as per defined scan rate. Select 1 to 10 Min. for the idle time if display scroll feature is required or else select disable.

**Scan Rate:** This is scroll time for the display pages. Select time interval between 5 sec to 30 sec. This time set is effective only if idle time is enabled selecting time between 1 to 10 min

#### LCD:

Brightness: Select level between 0 and 6. 0 is lowest brightness and 6 is for highest possible brightness

**Screensaver:** To WHolong the life of the LCD display, it is suggested to set the display turn-off time in 1, 10, 20, 30, 40, 50 or 60 minutes after the user operates the recorder. ***It was initially set 10 minutes for Screensaver from the factory.*** The recorder continues to record data while it is in the screen saving mode. The display turns on again by touch on the LCD screen

**Storage:** Select internal flash memory or SD card

#### Custom page:

**Allow download via Ethernet:** Enable/disable

## 4.7 Security


### 4.7.1 Normal

Path:  (Menu)-More-Config-select Instrument, then WHess “Enter”

Select “Security” = Normal

If the normal security is selected, for different users it needs just to key in a common password in maximum 18 characters. Once the password has been entered, the user needs to key in the password whenever **Config, Dump, Clear** or **Operate** soft keys are required. These keys enable the user to do configuration, dump data, clear data or manually operate the job. For easy access **Config, Dump, Clear** or **Operate** soft keys, the user may ignore the password.

How to enter simple password

 (Menu)-More-Config, select Password, WHess “Enter”, then key-in the password

## 4.7.2 CFR-21

If the higher security CFR-21 is selected, it is required to operate the recorder in more restricted rules which are complied with **FDA 21 CFR Part 11**

It has time limit during operation. If hands are off from keys in WHedefined set time which can be selected between 1 to 20 minutes using LogOut function, the user needs to key in password again. It also offers audit trail function to record the user, the timing and what type work he was doing on the recorder before. Incorrect password and unauthorized operation will be recorded into the event list as well.

In  (Menu)-More-Config-Select **Instrument**, WHess “Enter” soft button.

Select Security = CFR-21.

### Security Mode: CFR-21

- Logout: Disable
- Password validity: Unlimited
- Security Level of Functions
  - Login From PC: 9
  - Dump: 9
  - Clear: 9
  - Operate: 9
  - Config: 9
  - Pause: 9
  - ShutDown: 9

**LogOut:** Time selection available from 1 min. to 20 min. This selection is visible only if CFR-21 is selected

If no user operates the Paperless Recorder for the above set duration, then, current user will be logged out automatically

### Password validity:

If it is defined as 30, 60 or 90 days valid password, then it will request the user to key in a new password, or remain the old one after 30, 60 or 90 days.

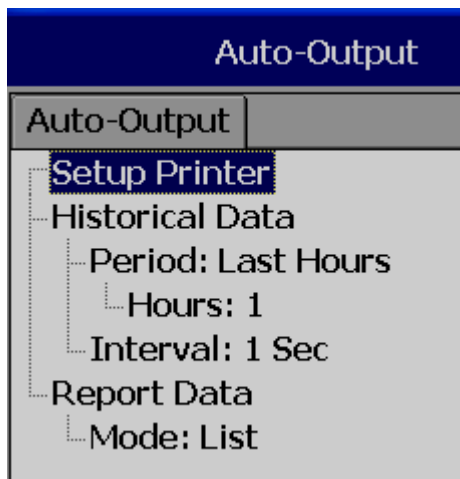
### Security levels:

0 to 9 levels are supported  
9 is the highest authority level, 0 is the lowest

## 4.8 Demo

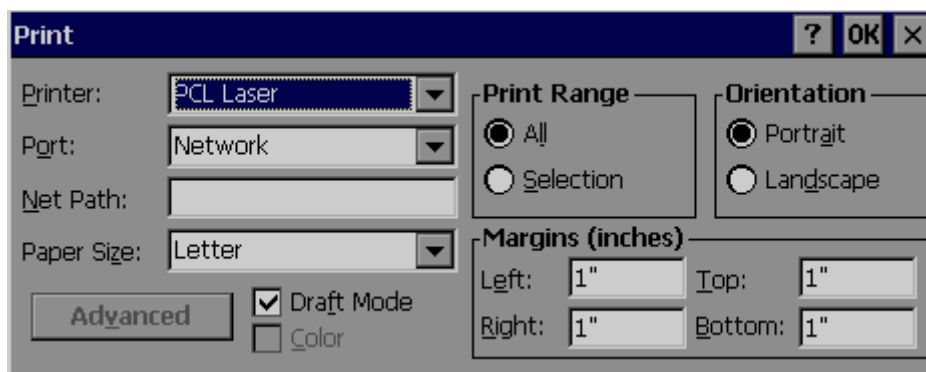
The Demo mode is a simulation mode used as a sales tool for demonstration purposes. It was set to simulate AI analog inputs and Math. *To start the automatic demonstration, first enable Demo mode, then turn the power OFF and Power ON to make it effective. To stop the automatic demonstration and return to real mode with real inputs, first disable Demo mode, then turn the power off and Power ON.*

## 4.9 Auto-Output



**SetUp WHinter:** It is to configure WHinter

Select Setup WHinter and then WHess "Enter" soft button



Two kinds of WHinters are supported. One is USB WHinter for page WHinting and another is Serial WHinter for Line WHinting

Applications: WHint Historical data, events, & Reports and snapshot directly from Paperless Recorder.

### 4.9.1 USB WHinter

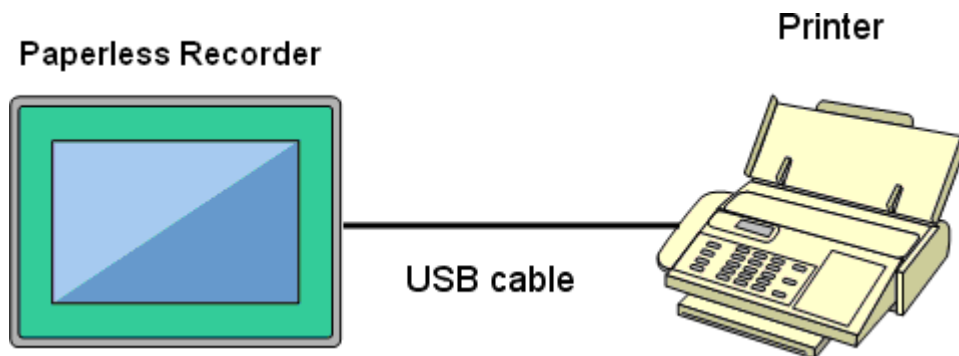
Generally, USB WHinter support PCL WHotocol. It means, it will support Page WHint, but not line WHint. We support PCL language 4, 5 & 6

If USB WHinter supports ESCP WHotocol similar to EPSON LQ300+, then, it is possible to take line WHint.

Please refer WHinter user manual for exact WHotocol details




Do not use USB WHinter supporting only PCL to WHint single line alarms, otherwise, pages will be wasted



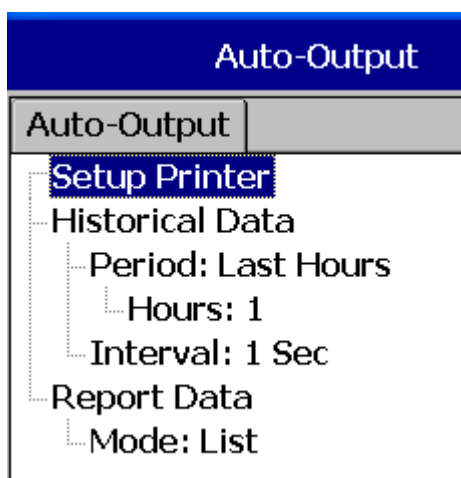
WHocedure

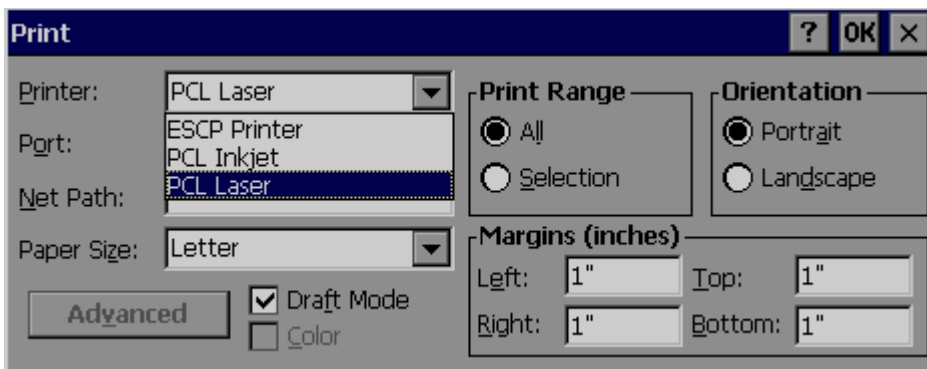
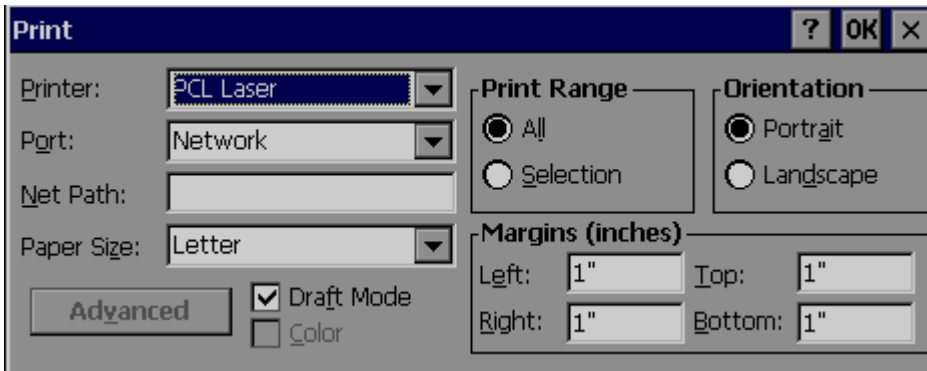
Connect Recorder to WHinter via USB cable

Power ON WHinter

Path:  (Menu)-More-Config-Auto-WHinter, Enter

Select "Setup WHinter", WHess "Enter" soft button





**WHinter:** PCL Laser, ESCP WHinter, PCL Inkjet available by default. Select one from the list as per WHinter model connected to the Paperless Recorder

**Port:** It shows "Network" by default. Once WHinter connected to USB port, it will show "LPT1" for the USB WHinter, select "LPT1"

**Net Path:** It is required to enter correct network path here only if both WHinter and Paperless Recorder are connected to LAN network

**Paper Size:** A4, B5, Legal and Letter are supported

**Draft mode:** By default, it is selected. If more quality WHint is required, deselect Draft Mode

**Color:** Enabled for Inkjet WHinter

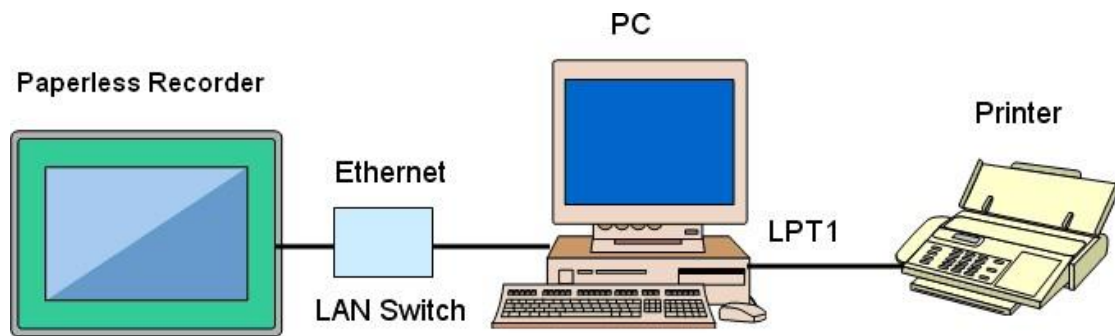
**Orientation:** Select Portrait/Landscape as per requirements

Note: Margins & WHint Range are not working at this time.

Now, setup is ready at Paperless Recorder

## 4.9.2 Network WHinter (LPT1)

Serial WHinter will WHint minimum one line and generally used for WHinting Real time alarms. Also, it can be used for WHinting historical data and alarms from Paperless Recorder. ESCP language supported. So, any WHinter supporting ESCP like LQ300+ can be used. LPT1 port of PC can be connected to Serial WHinter directly. However, it needs to install WHinter driver in PC first and share it for network use via Ethernet.



WHocedure

Connect Paperless Recorder to PC via Ethernet

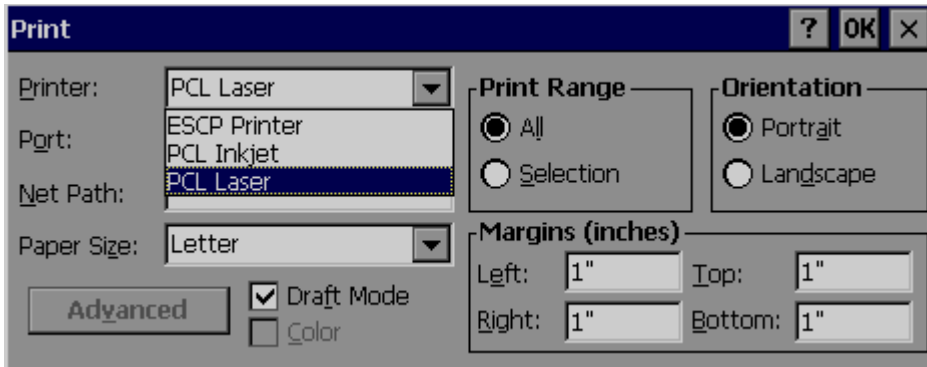
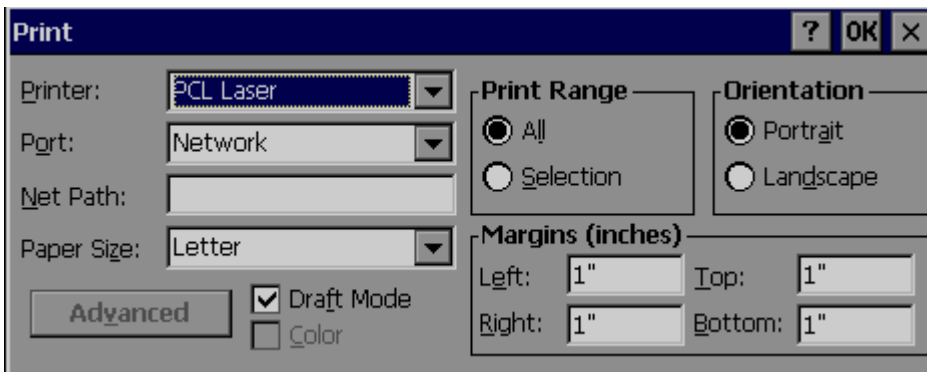
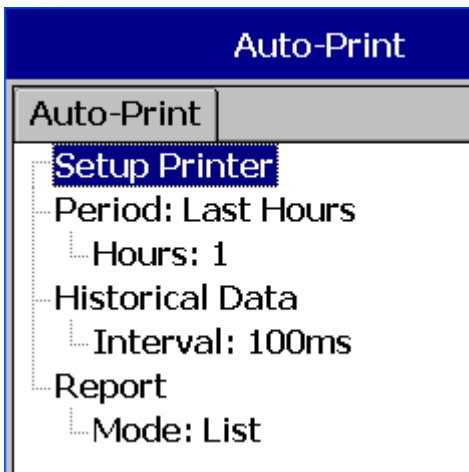
Install WHinter driver in PC. Share WHinter for network use

Connect WHinter to PC via LPT1

Power ON WHinter

In Paperless Recorder, at Path, select  (Menu)-More-Config-Auto-WHinter, Enter

Select "Setup WHinter", WHess "Enter" soft button



Select ESCP WHinter.

Then, enter Net Path WHoperly. Ex: \\PC1\LQ300

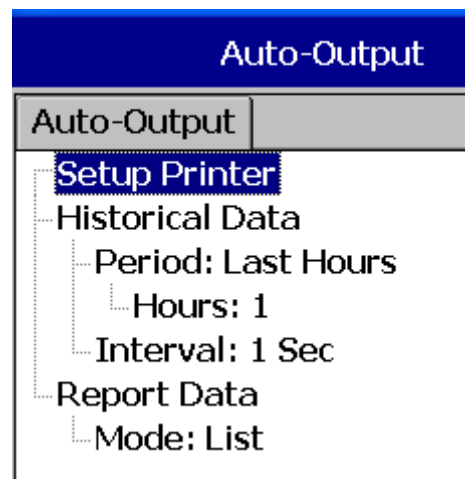
Where, PC1 is computer name and LQ300 is shared WHinter driver for network use

Now, setup is ready at Paperless Recorder

### 4.9.3 WHint Historical data

Configure USB WHinter or Network WHinter as explained in earlier section

In Paperless Recorder, at Path, select  (Menu) -More-Config-Auto-Output, Enter



**Period:** Select Last hours or Last days

**Hours/Days:** Select no. of hours or no. of days as per above selection

**Interval:** Select intervals of 100 msec/1 sec/2 sec/ 5sec/ 10 sec/ 20 sec/ 30 sec/ 1 min/ 5 min/ 10 min.

WHint function available in the Job list and it can be initiated in various ways.

Ex: WHint historical data of last 1 hr. and do this every day at 8.00 hrs

Timer					
1	2	3	4	5	6
Type: Daily					
Action: Enable					
Time					
Hour: 8					
Min: 0					
Sec: 1					
Job1: Print Historical Data					
Job2: No Action					

Set Job X

Print Historical Data

Job Items:

- Enable Totalizer
- Disable Totalizer
- Preset Counter
- Reset Counter
- Inc Counter
- Dec Counter
- Log Report
- Reset MinMaxAve
- Print Historical Data
- Print Event List
- Print Report List
- Print Snapshot
- Output Historical Data

Target

▲

▼

OK

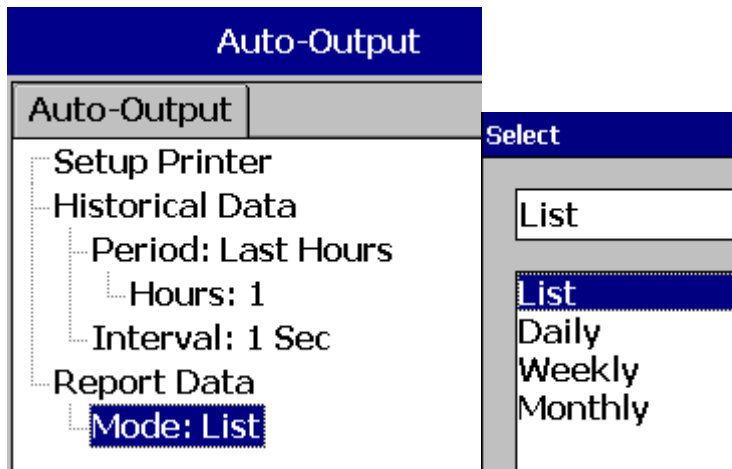
◀

▶

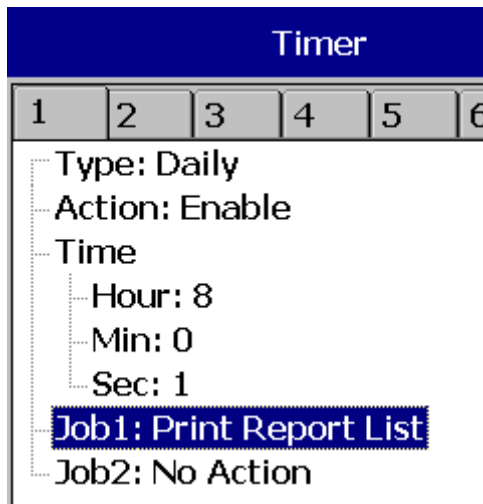
Cancel

#### 4.9.4 WHint Reports

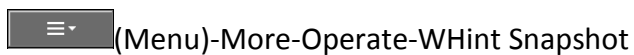
In Paperless Recorder, at Path, select ☰ (Menu)-More-Config-Auto-Output, Enter



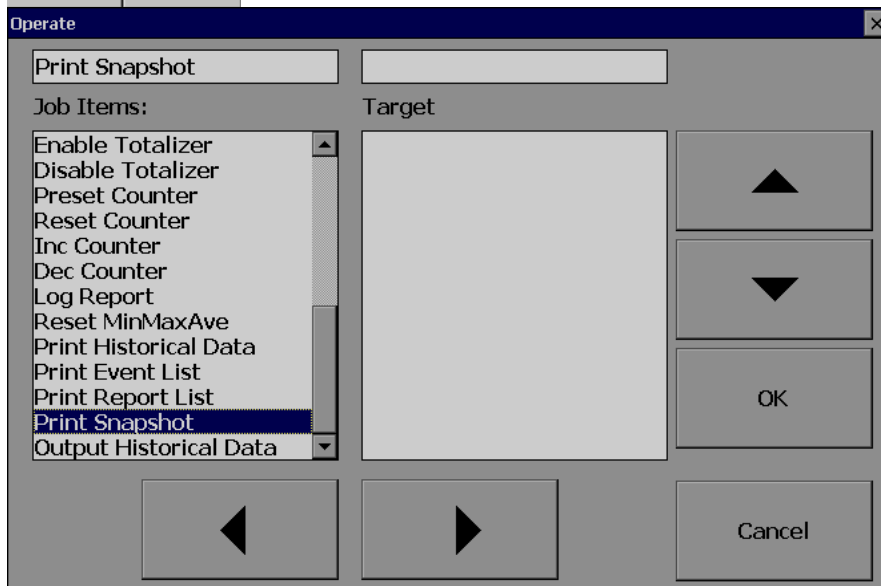
In the Mode, select which kind of Reports are required. Available options include Daily Reports, Weekly Reports and Monthly Reports



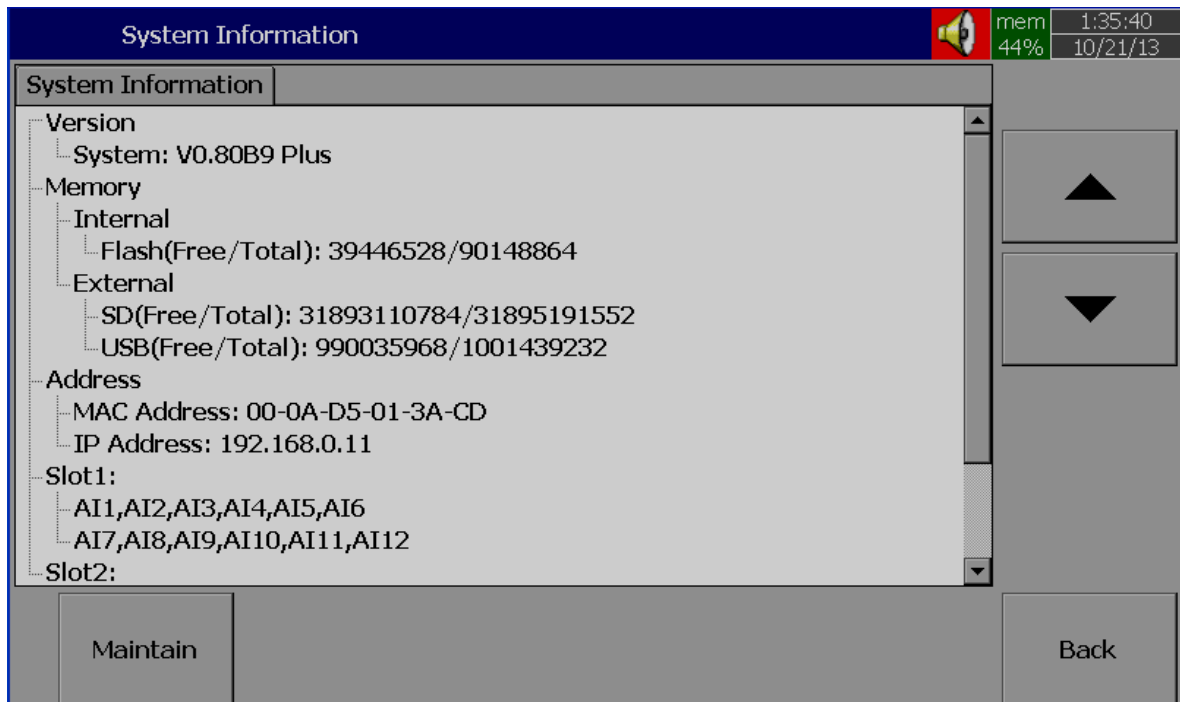
#### 4.9.5 WHint Snapshot




Menu	
Realtime	
Mode	Dump
Alarm	Clear
Status	Operate
History	Config
Event	Stop
More	ShutDown



## 4.10 System Info



Path:  (Menu)-More-Config-System Information

The system information includes System version, Internal and External memory, Ethernet IP address and Slots status

**Version:** It is the firmware version of the recorder.

**Memory (Free / Total):**

**Internal:** Indicates the percentage of free memory to total memory available in internal flash card

**External:** Indicates the percentage of free memory to total memory available in external memory devices of SD and USB.

A small icon on the top right indicates the percentage of free memory e.g.: Mem 96 %

**Address:**

**MAC:** Display MAC address of Paperless Recorder

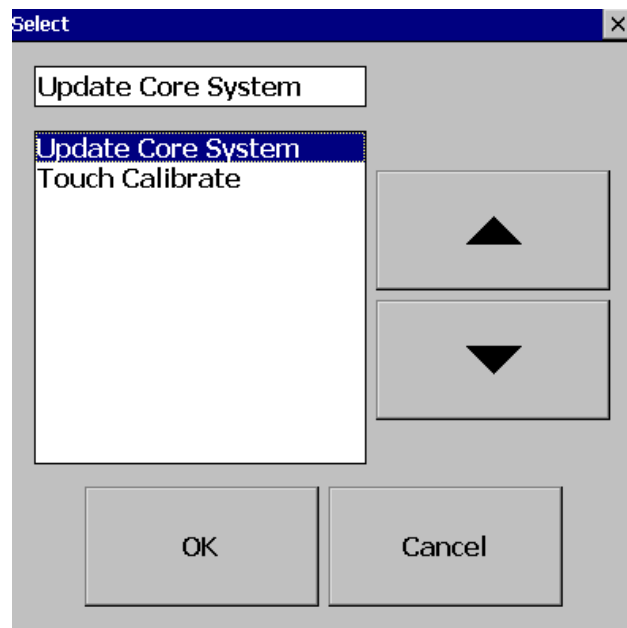
**IP address:** Display IP address for the Paperless Recorder

**Slot 1..5:** Indicates the status of all Slots and the cards been inserted in. The cards include Analog Input AI, Digital Input DI and Digital Output DO & AO.

#### 4.10.1.1 Upgrade Firmware

Path:  (Menu)-More-Config-System Information-Maintain

**Maintain:** The Maintain button is located at left lower side in System Info. page. It is the button to upgrade the firmware and Calibrate touch screen in paperless recorder



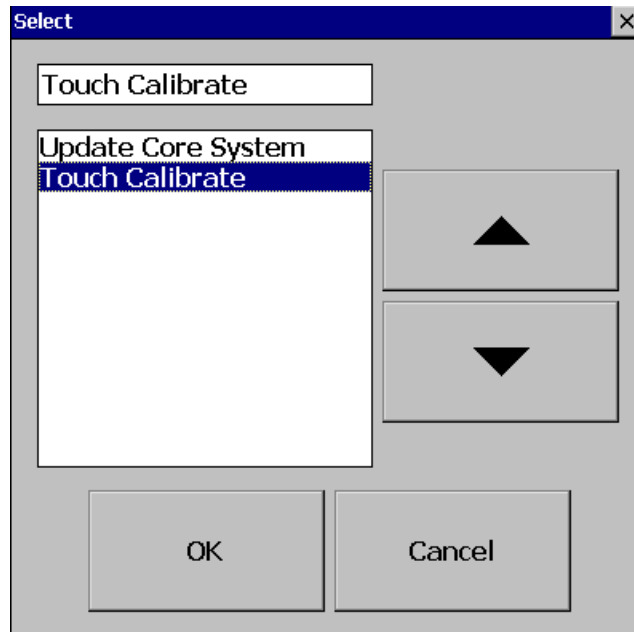
#### **Upgrade Core System:**

This is to upgrade firmware in paperless recorder. Contact factory/supplier for latest firmware files. Please download firmware file first to USB stick, then, insert USB stick at USB port at Paperless Recorder. Select 'Update Core System' and then click on "OK" button. It may take a few seconds to finish the WHocess. Please note that power supply should be not switched off during this upgrade WHocess

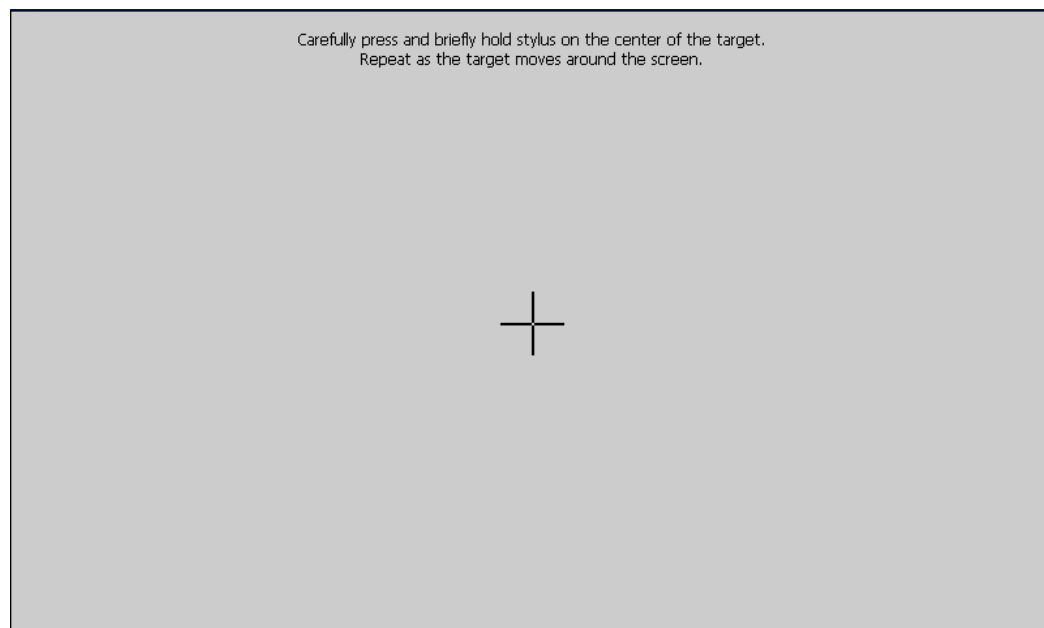
#### 4.10.1.2 Calibrate Touch Screen

Path:  (Menu)-More-Config-System Information-Maintain

**Maintain:** The Maintain button is located at left lower side in System Info. page. It is the button to upgrade the firmware and Calibrate touch screen in paperless recorder




This is to calibrate the touch screen. A "+" symbol appears in the center of the LCD screen. Carefully WHess and briefly hold stylus on the center of the target. Repeat this WHocedure as the target moves around the screen. Just touch the screen to complete the screen calibration. This WHocedure helps to locate pointer via touch screen and WHoperly select the objects during operation of the recorder

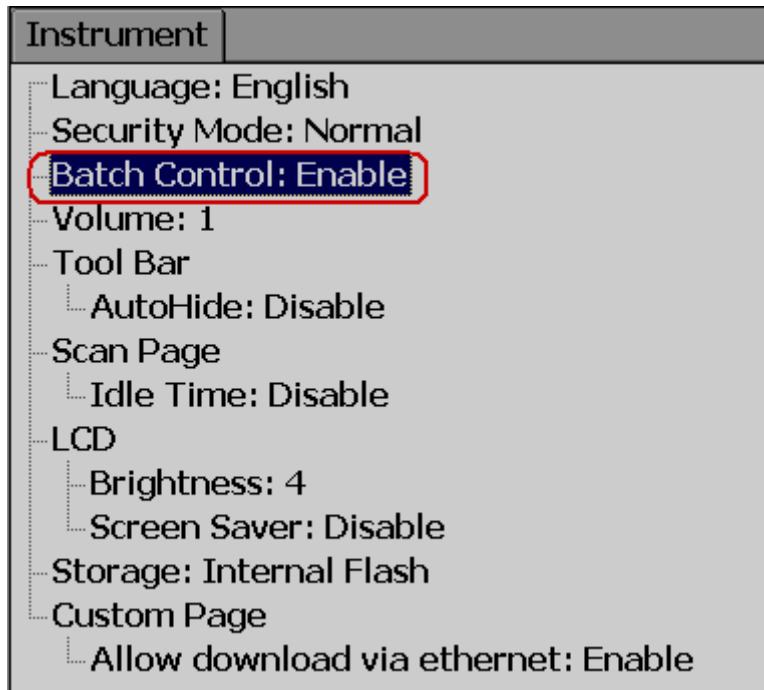


## 4.11 Batch Control

This feature is to store data in different folder for every batch and archive data later with reference to a batch.

Path:  (Menu)- More-Config- Instrument

Select Batch Control and WHess “Enter” key. Select “Enable”. WHess “Ok”




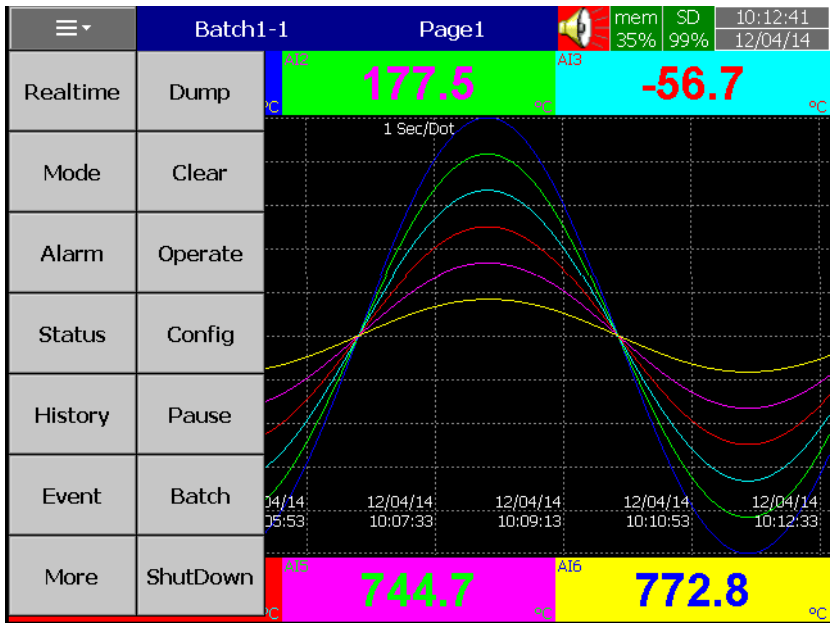
WHess “Back”





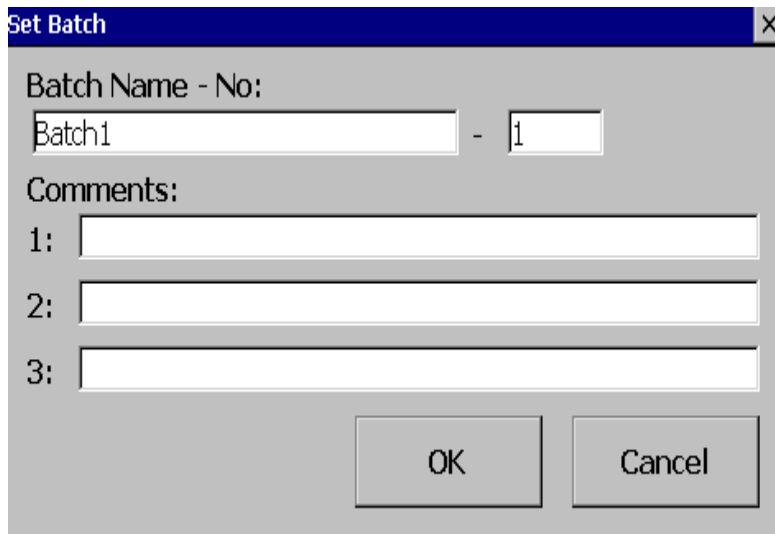
WHess "OK", then, WHess "Home" Soft key to save these settings

After Power ON, Then in the  (Menu), Batch soft key will be shown as below




Note: "Batch" soft key will appear only after Batch Control enabled as explained above

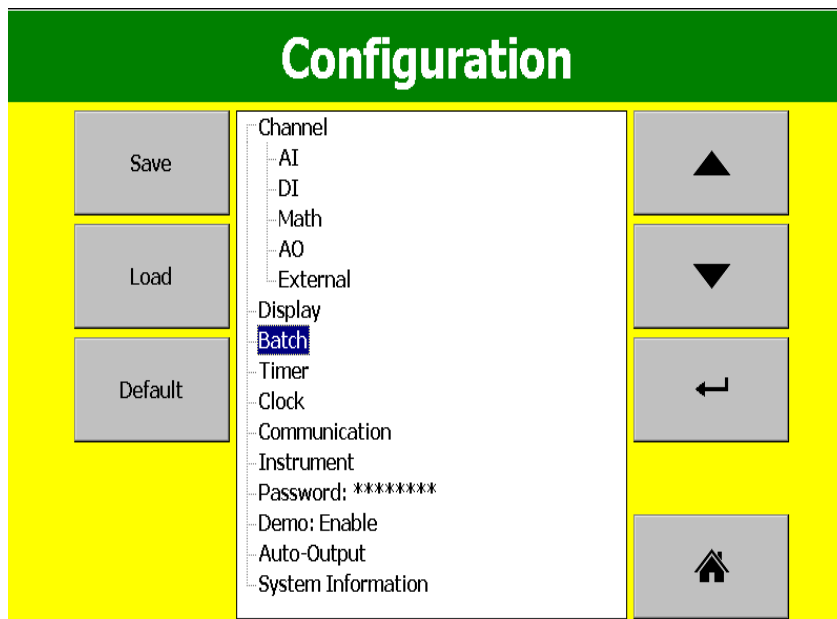
WHess on Batch and it shows the following screen



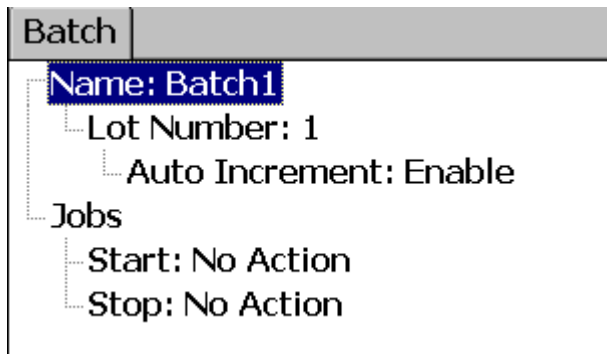
The image shows a 'Set Batch' dialog box with a blue title bar. It contains a 'Batch Name - No:' section with two input fields: the first contains 'Batch1' and the second contains '1', separated by a hyphen. Below this is a 'Comments:' section with three numbered input fields (1, 2, and 3), all of which are currently empty. At the bottom of the dialog are two buttons: 'OK' and 'Cancel'.

Operator can enter maximum three comments for any batch.

In the  (Menu)-More-Config, select "Batch", WHess "Enter" key



It will show the Batch control settings as shown below




**Name:** Enter Batch name. Maximum 18 characters are allowed. By default, it's Batch1

**Lot Number:** Enter the Lot number. If Auto increment is enabled, then Lot numbers will be incremented automatically by the recorder say Batch1-1, Batch1-2, Batch1-3 etc.. during every start of a new batch

**Jobs:** Two events, Start, Stop are available


**Start:** Start means Jobs that should be done during start of a new batch

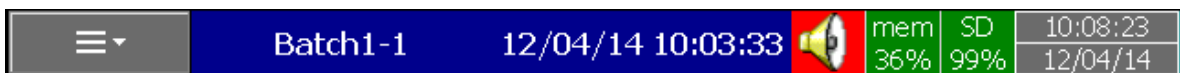
**Stop:** Stop means Jobs that should be done during stop of a batch

**Note:** When batch control is enabled, then recorder will be in Pause mode by default initially and it requires Starting of the recorder from the Menu by WHessing at  (Menu)- More than "Start". When recorder is not logging any data, Pause status shall be shown in the Top right area of the recorder as shown below



### How to do the batch control

WHess on  ("Menu") , "More", then "Start". Batch number will be shown in the recorder Top area.



To Stop this batch, WHess on "Menu", "More", then "Pause". It gives a message "Saving data" and updates batch data in the internal memory of the paperless recorder.

#### 4.11.1.1 Batch Example-1

Operator wants to start a batch every day at 8.00 hrs and stop the batch at 12.00 hrs.

Configuration

##### Timer1

Type: Daily            Action: Enable  
Time – Hour: 8            Min: 0    Sec: 1  
Job1: Start  
Job2: No Action

##### Timer2

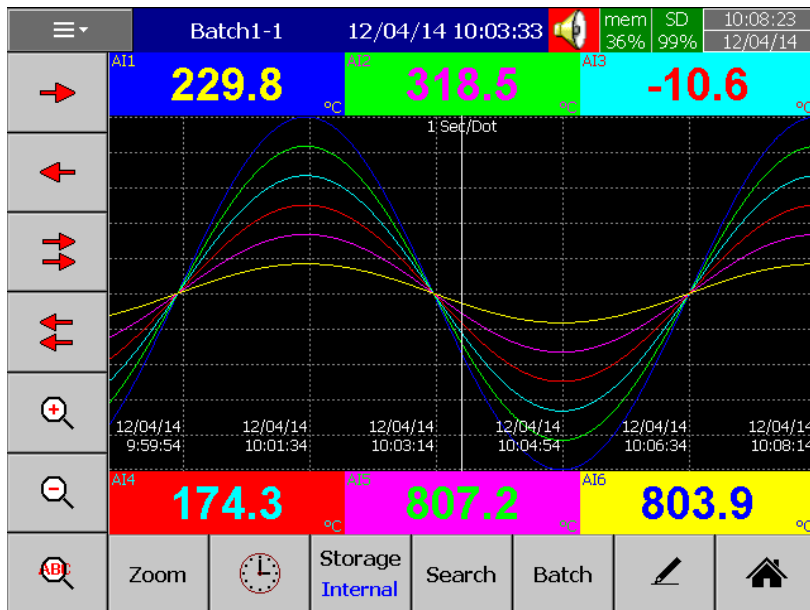
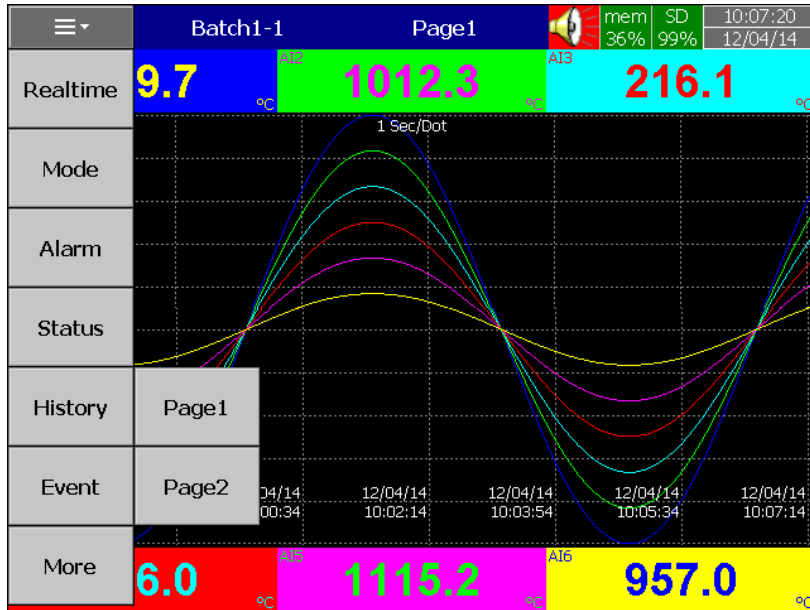
Type: Daily            Action: Enable  
Time – Hour: 12            Min: 0    Sec: 1  
Job1: Pause  
Job2: No Action

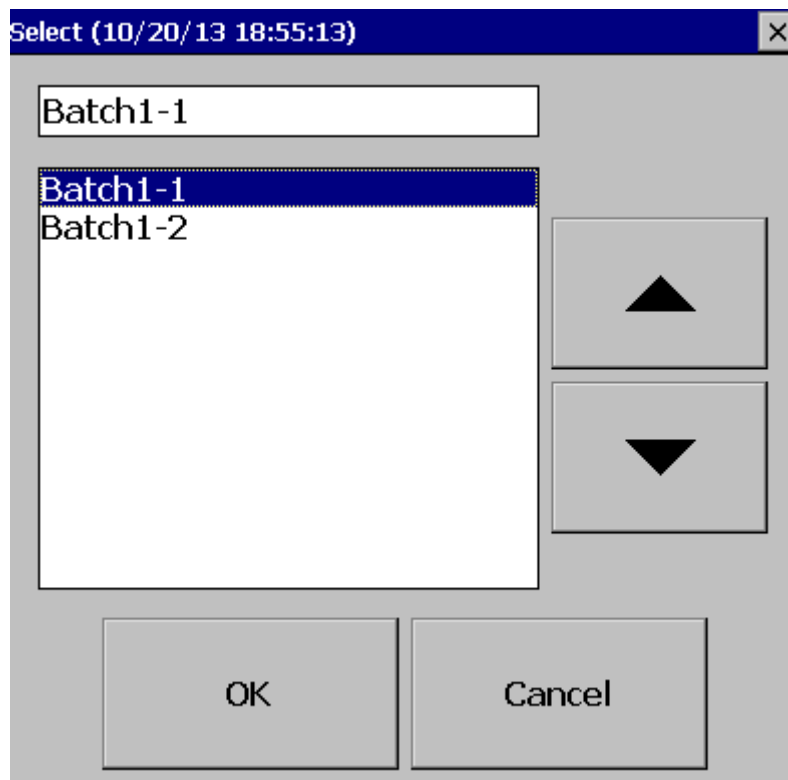
#### How to view batch data in Recorder ??

WHess on  (Menu)-History-Page1


WHess “Search”, select required Batch and WHess “Ok”

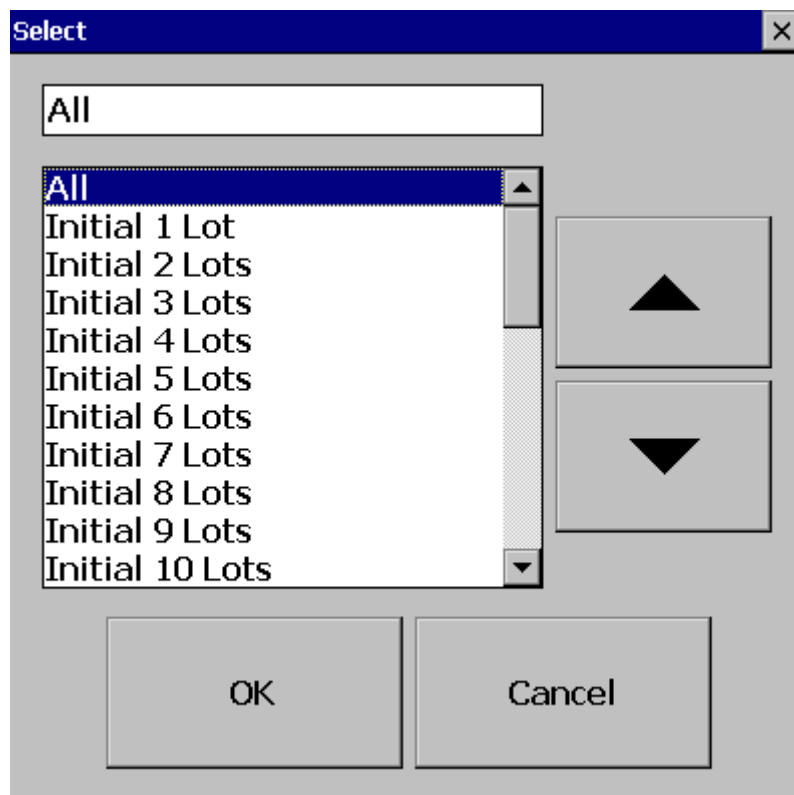
Batch details including lot number can be archived by WHessing soft key “Batch”





### How to Dump Batch data to external USB memory

WHess on  (Menu)-More then WHess on Dump

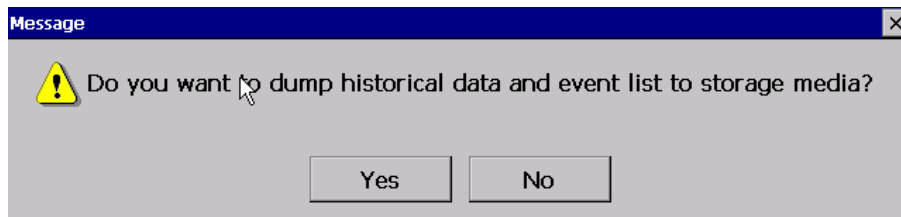


Select "All" or required lots and WHess "OK"

For ex: Batch1-1, Batch 1-2, Batch1-3 are available  
Initial 1 Lot means, Batch1-1  
Initial 2 Lots means, Batch1-1 and Batch1-2  
Initial 3 Lots means, Batch1-1, Batch1-2 and Batch1-3

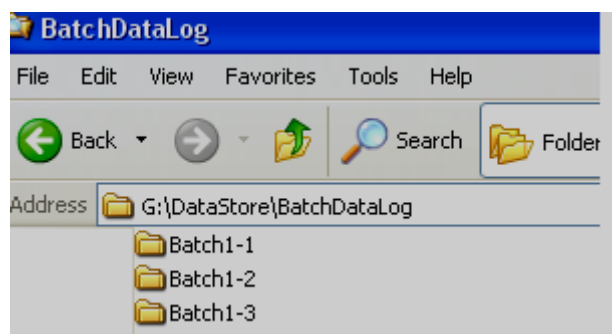
Note: WHovision not available to dump only specific lot.

Please refer Instrument->Data Transfer-> Transfer and Remain



WHess on “Yes” to dump data from internal memory to external SD Card or USB memory .

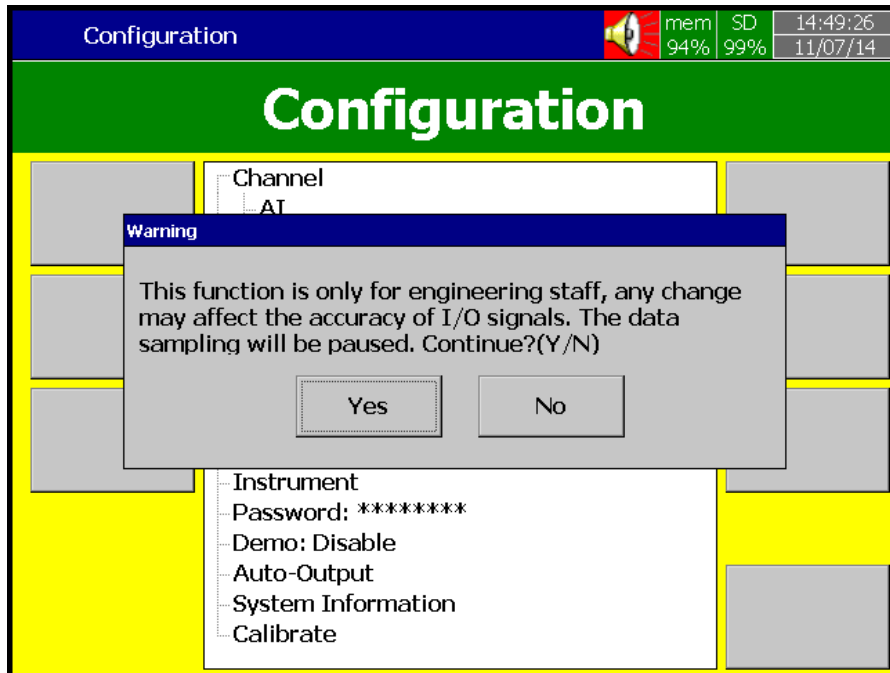
If you have 3 batches say Batch1-1, Batch1-2 and Batch1-3, then you can see three different folders in the external USB memory card after completing of dump



Please note that the data available in USB memory is in WHOWhietary format to avoid any kind of tampering and you need PC software to view this data.

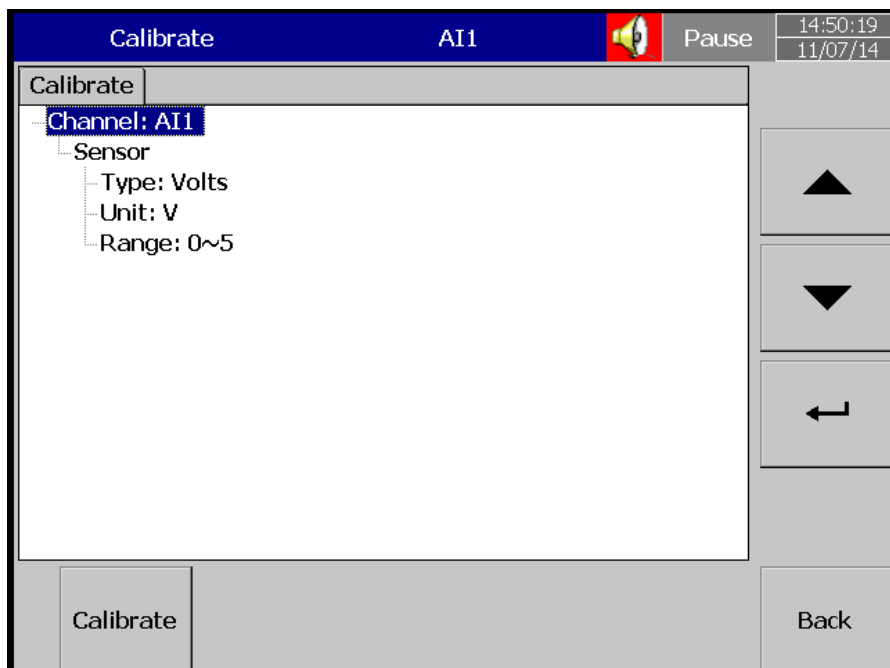
## 4.12 Calibrate

This function is used for calibrating Individual Analog channel.

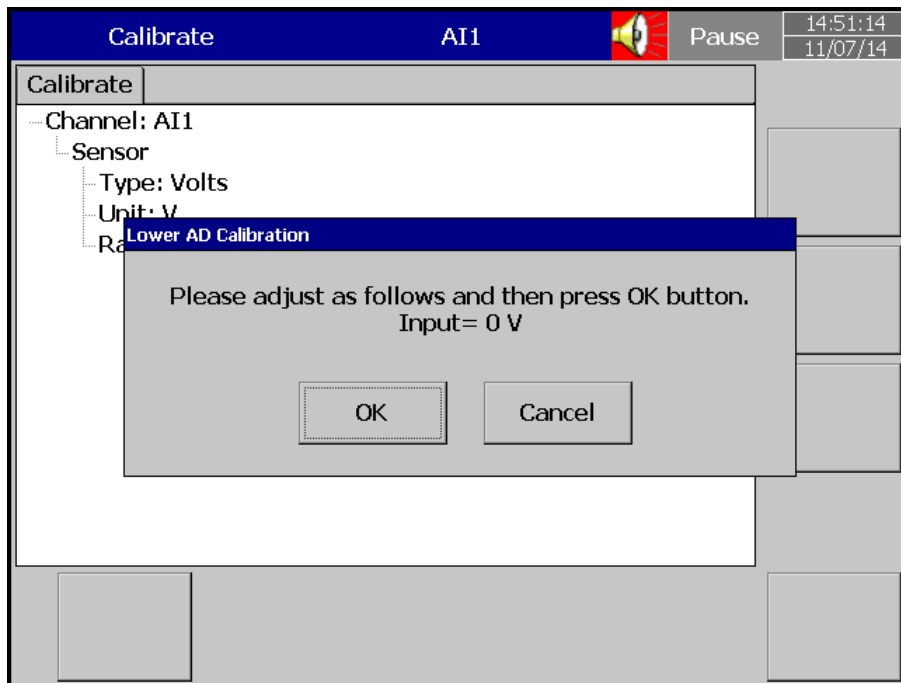


For Eg:

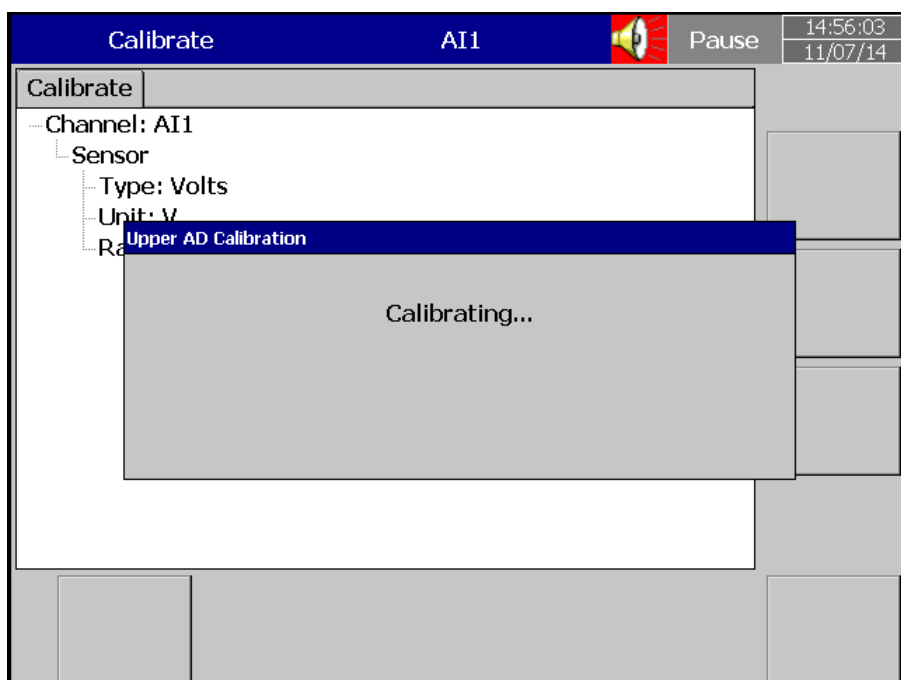
If you are calibrating an AI (0-5V). When you click Calibrate menu , User can see the below screen. Then please click calibrate as shown in the below screen



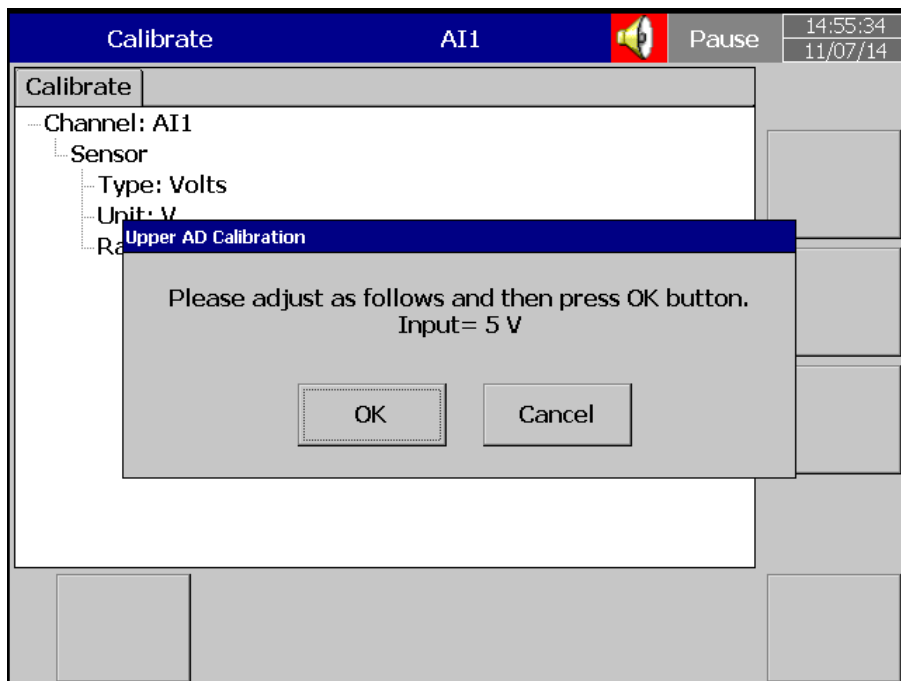
Please follow the next instruction, inject 0V in to the input which can be seen in below screen



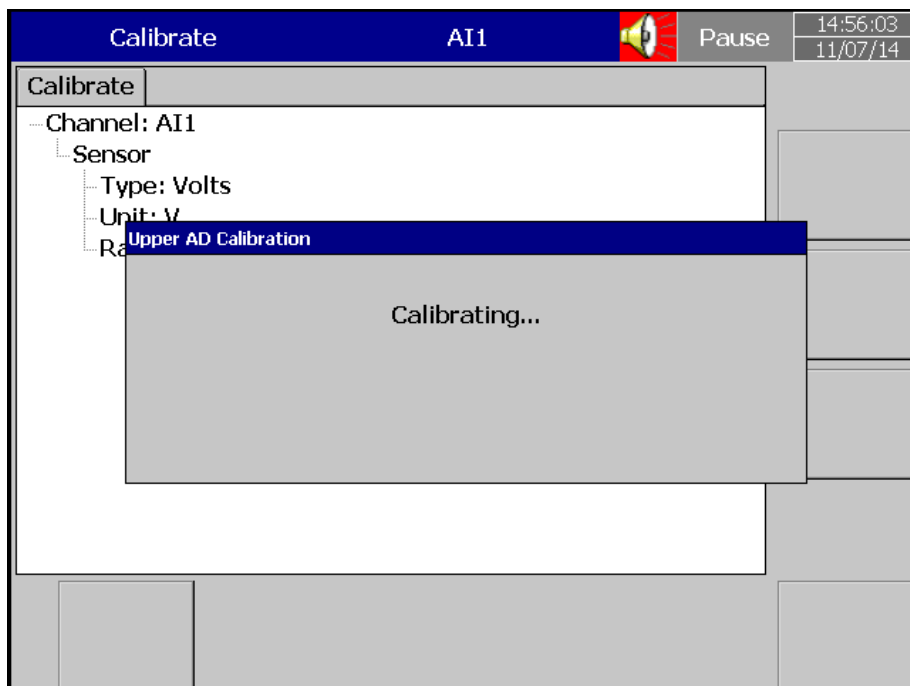
After you inject and select ok , User can see the below screen  
Now follow the next instruction



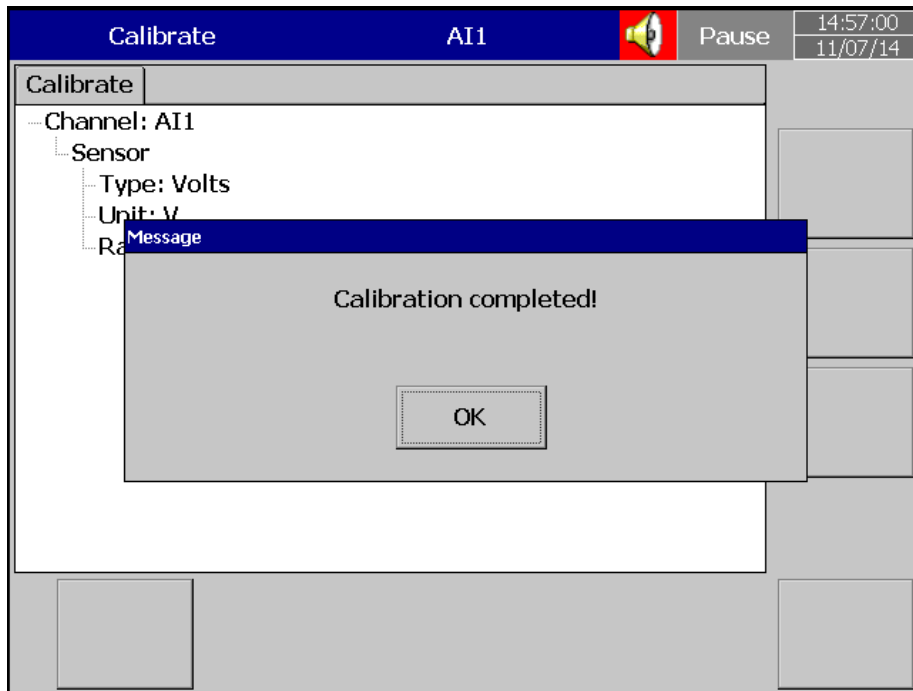
Now inject 5V and click ok



After you inject and select ok , user can see the below screen  
Now follow the next instruction



When the calibration is done successfully , the user can see below screen.



## 5. PC BASED SOFTWARE

By using this software you can configure the settings of the Recorder offline and online. Trends of configured channels can be viewed in PC by using this .

This has got 4 Options:

### 5.1 Free Basic Software

#### 5.1.1 Requirements

##### Hardware


Recommended hardware  
PC with 3G GHz WHocessor, 512 MB RAM  
50GB free space in the hard disk.  
Ethernet port, RJ 45 female/ USB port

#### 5.1.2 Operating system

Windows based Operating systems, Windows XP, Windows 7, Windows 8 etc..  
32 bit and 64 bit operating systems are supported

#### 5.1.3 Software

Software installation

1. Install latest dotNet software from Microsoft website
2. Install the software
3.  Historical viewer icon desktop shortcut will be created after installation of software
4. Historical viewer can be accessed from the following path as well
5. Start-WHograms-Historical viewer-Historical viewer.

The Software contains:



HIST\_VIEWER is for monitoring historical trends and also for configuration of recorder parameters in PC.

### Uninstall the free Software

This is to remove WHevious versions of free software from PC.

### HIST\_VIEWER



On how to set configuration of the Recorder from PC.

Start-WHograms-Historical Viewer

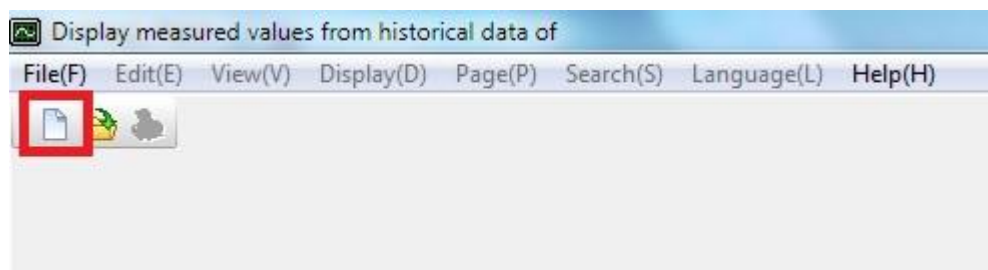
Tool bar



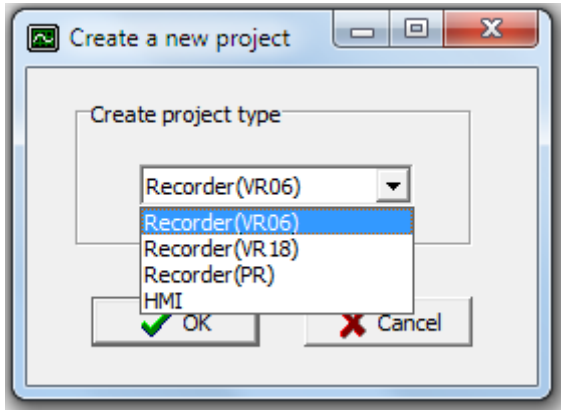
To open new WHOject



To open existing WHOject file

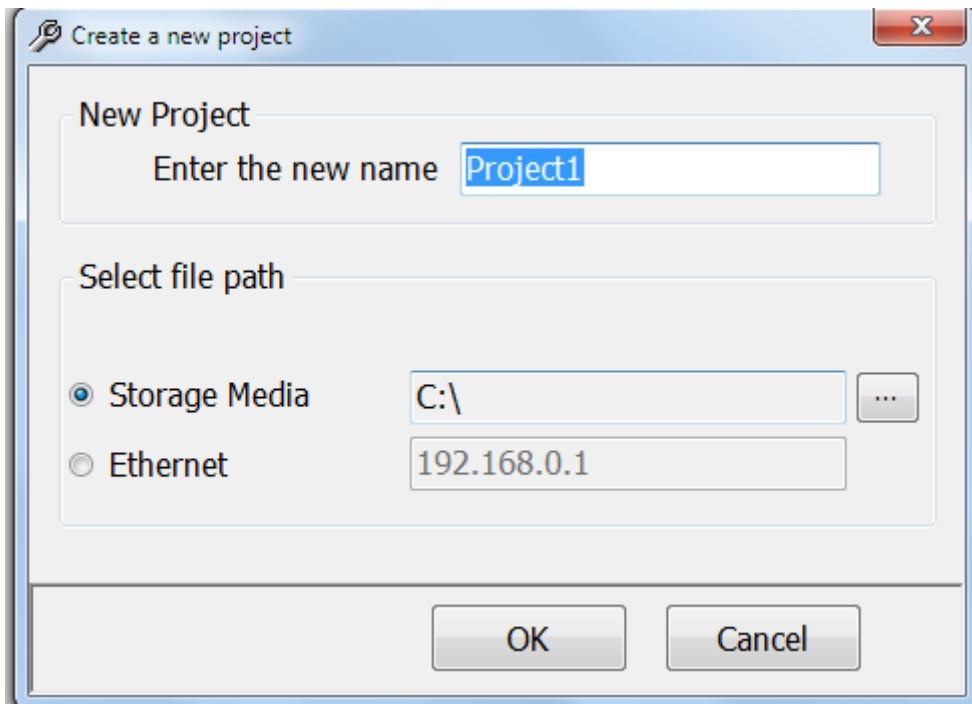


When the User clicks the icon new ( shown in the above picture, squared), they can view the below menu, and accordingly they can select the Recorder (WH) and click ok.

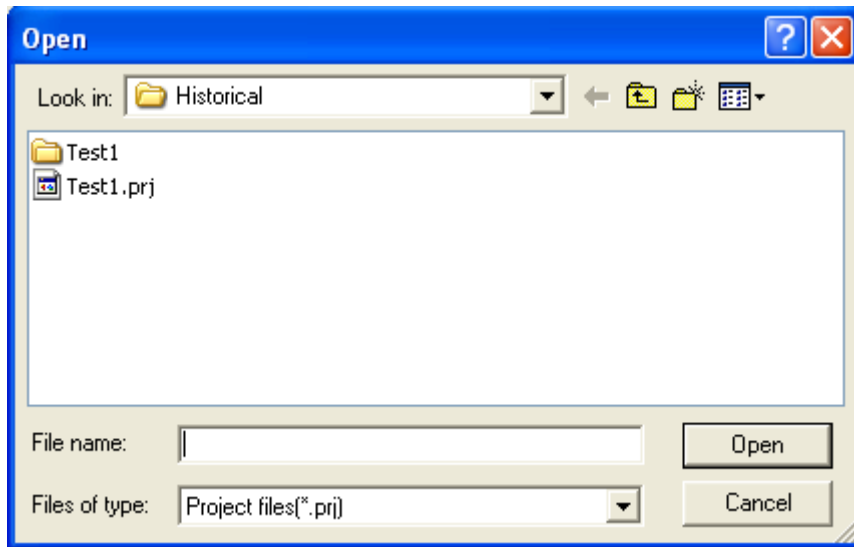



After that User has to give a name to the WHoject and select the location of WHoject ( as shown in the below figure). If the user has already got the configuration in a SD card or USB , they can select the path accordingly.


If the User for the first time wants to configure the Recorder , then they have to select Ethernet, and enter the correct IP address of the Recorder.




If the User wants to open file in the software, already configured in the PC, then they can select \*.WHj file to open the WHoject.



 To save the WHoject file settings in PC

 Receive configuration (Storage Media/Ethernet)

 Send configuration (Storage Media/Ethernet)

If the software is already configured in the PC, then you can select \*.WHj file to open the WHoject.

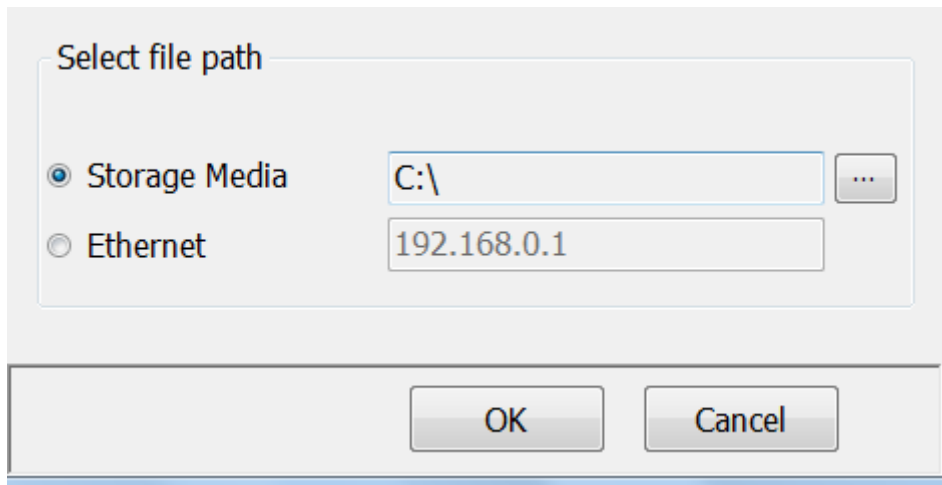
**Bank** 

This is used to select physical connection between the Recorder and PC.

two options are available:

Storage Media

Ethernet



Standard Ethernet port (RJ 45 female) shall be available at the Recorder. RS 232/RS485 shall be supplied as additional options.

#### 5.1.4 Ethernet Configuration

It is possible to use PC software for data logging of Recorders connected on standard Ethernet. Maximum 1024 tags can be configured for data logging, archiving and analysis. The tags cover AI, Math, DI, DO, Counter & Totalizer.

1. Make sure that network adapter in PC is properly configured. IP address, Subnet mask and Gateway should be configured at the PC for using Observer II program. Please contact System administrator to set Unique IP address for the PC.
2. Install Observer II application software in PC. The software may be installed from setup available in the CD supplied as per the order.
3. Ethernet configuration at Recorder

Please refer to **4.5 Communication** for entering IP address, subnet mask and gateway address manually at the Recorder.

Gateway refers to a device on a network that sends local area traffic to other networks.

Subnet mask numbers help to define the relationship between host and rest of the network.

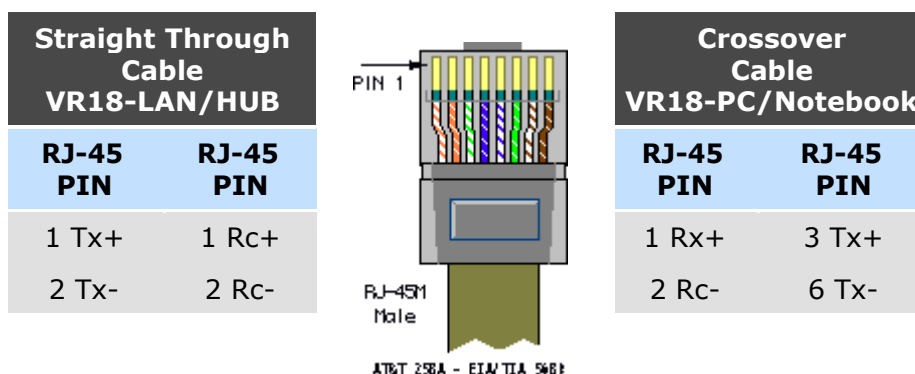
For every LAN, the Network administrator shall define Subnet mask and Gateway. Obtain subnet mask and gateway address for the LAN at the place where the Recorder to be connected. Enter these details at the Recorder manually using front buttons.

By default, subnet mask address: 255.255.255.0

By default, Gate way: 0.0.0.0

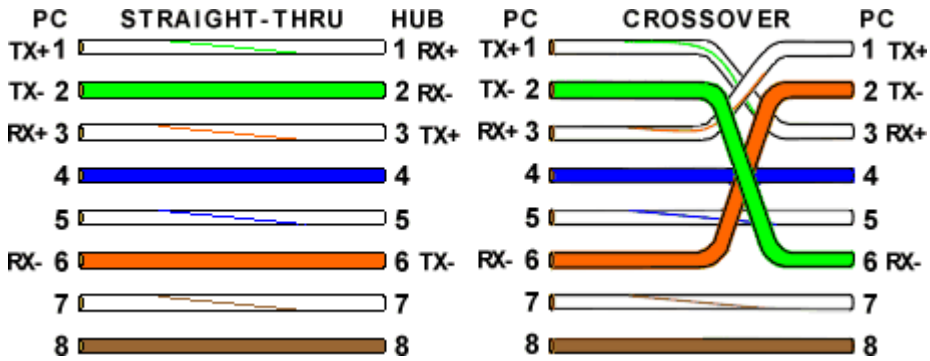
Allocate the Unique IP address to the Recorder and enter IP address at the Recorder manually. Contact System administrator for obtaining free IP address available at user LAN. Naming duplicate IP address may disable the communication between the Recorder and PC/LAN HUB.

- Local area network uses UTP cable for Ethernet connectivity. Maximum UTP cable distance between the Recorder and LAN/HUB/PC should be less than 100 Meters. If the distance is more than 100 Meters, additional LAN accessories/equipments may be required for increasing signal strength. Please contact network administrator for more information on extending LAN.
- Two different types of cables shall be used for connecting the Recorder on Ethernet as follows. For connecting the Recorder to LAN HUB, then standard straight-through Ethernet cable should be used. For connecting the Recorder to PC/Notebook directly, then crossover Ethernet cable should be used.



3 Rc+	3 Tx+
6 Rc-	6 Tx-

3 Tx+	1 Rc+
6 Tx-	2 Rc-



- Connect WHoper UTP Ethernet cable as per the requirements and observe the communication status between the Recorder and PC/LAN HUB at the LED's dedicated for the purpose near female RJ 45 connectors.

Recorder side

Link (Green LED)

Green lit: Cable connected between the Recorder and PC/LAN HUB

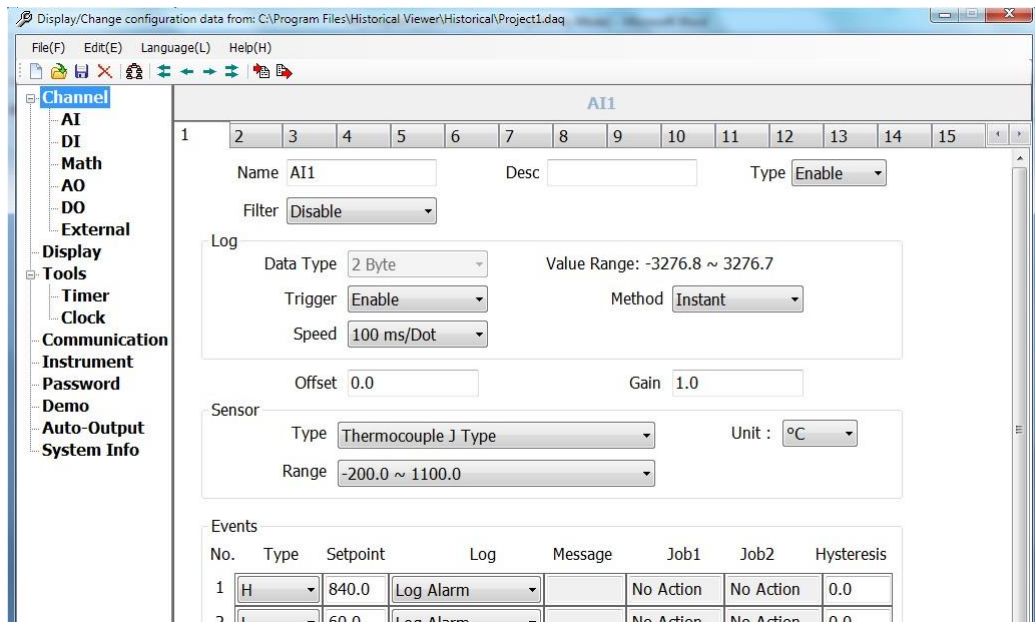
Green Off: No Link between the Recorder and PC/LAN HUB

Tx/Rx

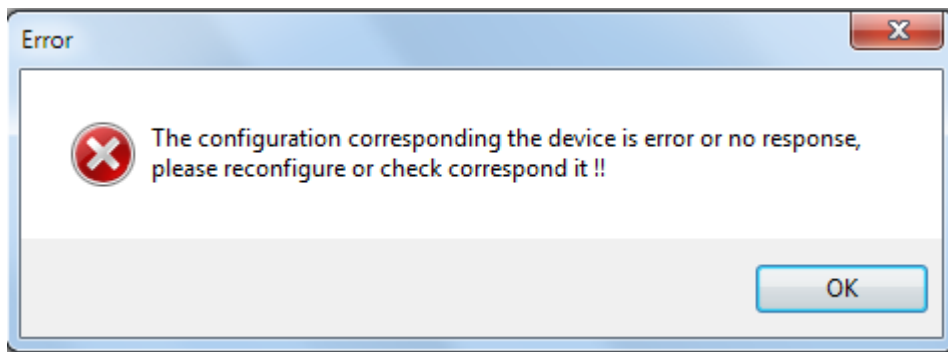
Orange Lit continuous: No cable connection

Orange slow blink: Communication established between Recorder & PC/LAN HUB

If the download is successful, the User can see the below screen.



If Upload is unsuccessful, it shown message as “No response from Recorder, connection fails”.



If this is the case, please check the Ethernet cable connections at both the Recorder and PC/LAN HUB side. Also make sure that green communication LED available for WHoper firm connection at RJ 45 connector.

If still communication is not established between the Recorder & PC, then once again check Subnet mask and gateway address at the Recorder & PC. Contact Network/ System administrator for WHoper Ethernet configuration of the Recorder & PC. Please note that Recorder should have unique IP address in the network and PC being used for Observer II shall have separated Unique IP address in the network.

## 5.2 Data Acquisition Studio Software

## 5.2.1 Requirements

### Hardware

Recommended hardware  
PC with 3G GHz WHocessor, 512 MB RAM  
50GB free space in the hard disk.  
Ethernet port, RJ 45 female/ USB port

## 5.2.2 Operating system


Windows based Operating systems, Windows XP, Windows 7, Windows 8 etc..  
32 bit and 64 bit operating systems are supported

## 5.2.3 Software

### Software installation

6. Install latest dotNet software from Microsoft website
7. Install Data Acquisition Studio software



Historical viewer icon and Real time viewer icon , desktop shortcut will be created after installation of software

Historical viewer can be accessed from the following path as well  
Start-WHograms-Historical viewer-Historical viewer

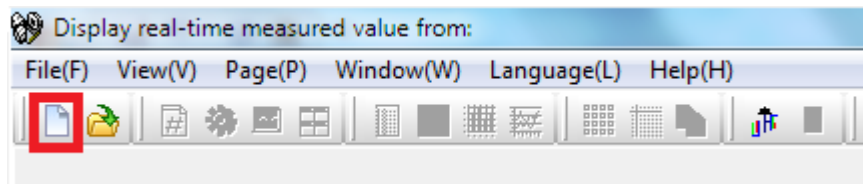
Real time viewer can be accessed from the following path as well  
Start-WHograms-Data Acquisition StudioStudio- Realtime viewer

## 5.2.4 How to configure Communication Bank

It is to set path for the data transfer. It's important to setup "Bank" WHoject at the firsthand to WHOceed further

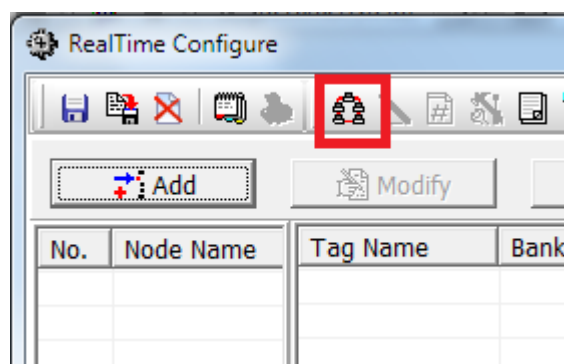
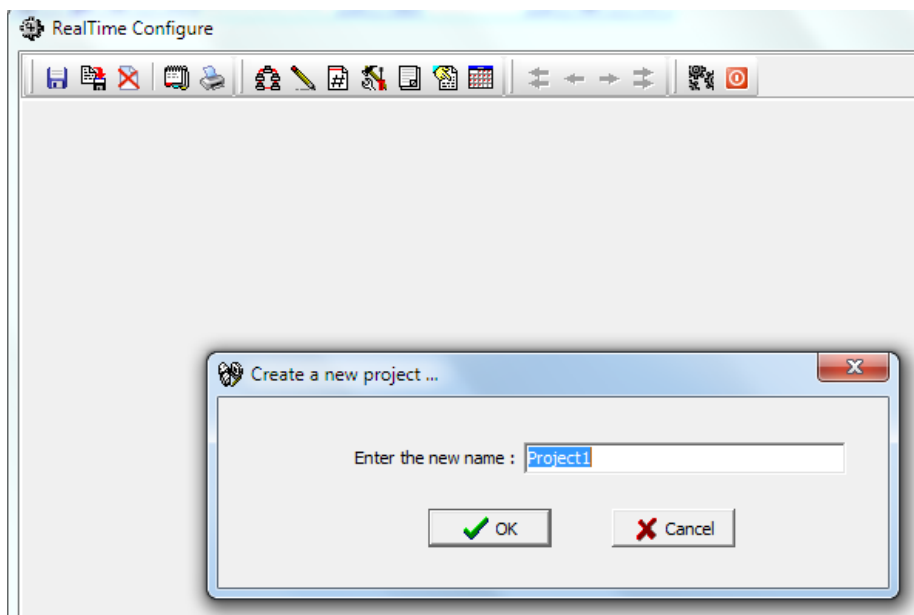
1. Open existing WHOject or create a new WHOject from RealTime viewer using one of the following options


#### Start-WHograms-Data Acquisition Studio-Realtime Viewer

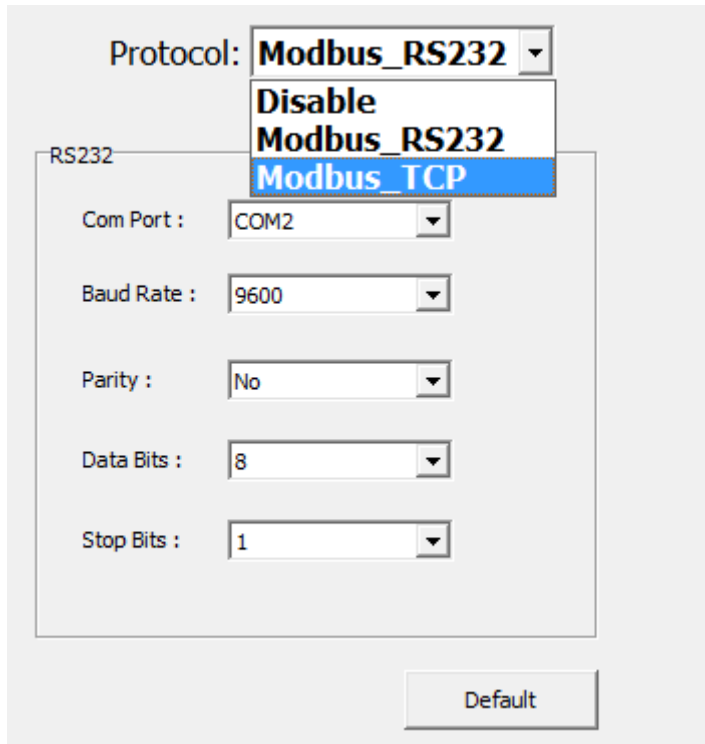


Click on new WHOject as shown in square icon in the above figure

Then the User has give name to the WHOject as shown in the below figure



Click at bank icon  to open communication bank configuration, and select the bank bank accordingly.



Protocol: **Modbus\_RS232** ▼

Disable  
Modbus\_RS232  
**Modbus\_TCP**

RS232

Com Port : COM2 ▼

Baud Rate : 9600 ▼

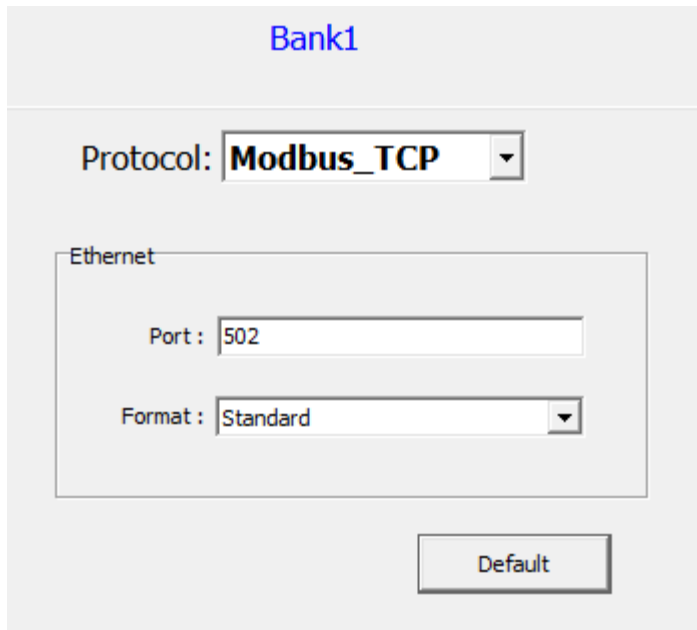
Parity : No ▼

Data Bits : 8 ▼

Stop Bits : 1 ▼

Default

If Recorder is connected to Ethernet, then select Modbus\_TCP as shown below



Bank1

Protocol: **Modbus\_TCP** ▼

Ethernet

Port : 502

Format : Standard ▼

Default

If Recorder is connected on Serial RS-232 or RS-485, then select Modbus\_RS232 as shown below. Please select the com port , baud rate as in the instrument.

## Bank1

Protocol: **Modbus\_RS232** ▼

RS232

Com Port : COM2 ▼

Baud Rate : 9600 ▼

Parity : No ▼

Data Bits : 8 ▼

Stop Bits : 1 ▼

Default

## 5.2.5 How to configure Recorder

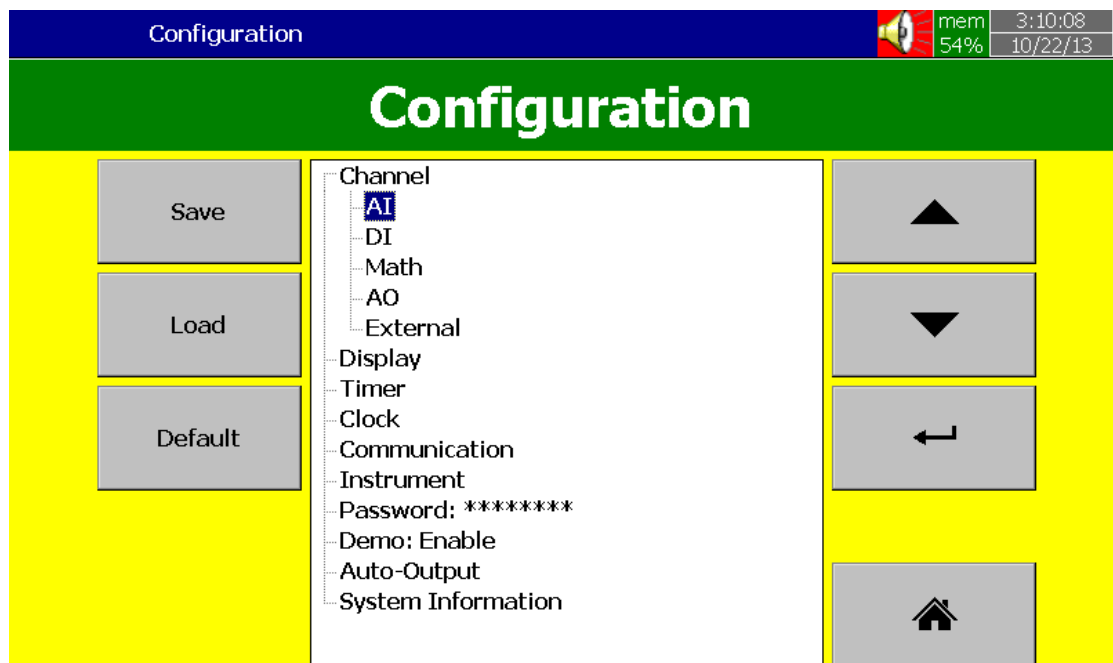
Three ways

Touch screen, Software and Storage Media.

## 5.2.6 Touch Screen

It is possible to configure Recorder directly from Touch screen

WHess Menu-Config



Please refer chapter 4 for more details

## 5.2.7 Ethernet

The steps are given below

1. Connect Recorder to PC via cross over or straight Ethernet cable

2. Check IP address of your Computer. Make sure to set IP address of Recorder in same domain as your PC  
For ex: IP address of your computer: 192.168.0.200  
You may set IP address of Recorder as 192.168.0.11
  
3. WHocedure to set IP address manually at Recorder  
Menu-More-Config-Communication, WHess "Enter"  
IP = Select User Define  
Select, IP address: 192.168.0.11 (Default) and WHess "Enter" to change if required  
Subnet mask: 255.255.255.0  
Default Gateway: 192.168.0.1
  
4. Use Ping from DOS WHompt and check communication is ok or not. If no response, then, check cable or IP address at your computer or IP address at computer

```

C:\ Command Prompt
Microsoft Windows XP [Version 5.1.2600]
(C) Copyright 1985-2001 Microsoft Corp.

E:\Documents and Settings\Mahi>ping 192.168.0.11


Pinging 192.168.0.11 with 32 bytes of data:


Reply from 192.168.0.11: bytes=32 time<1ms TTL=128
Reply from 192.168.0.11: bytes=32 time<1ms TTL=128
Reply from 192.168.0.11: bytes=32 time<1ms TTL=128
Reply from 192.168.0.11: bytes=32 time<1ms TTL=128

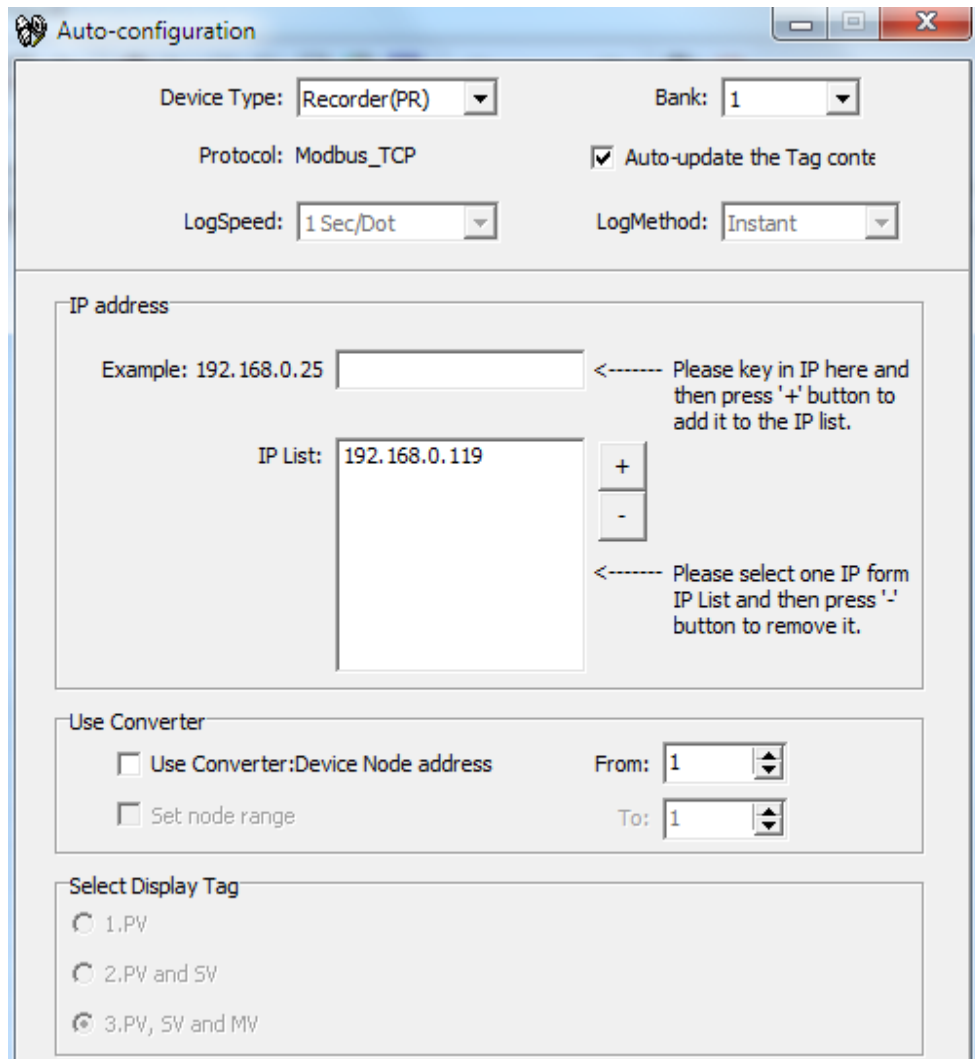
Ping statistics for 192.168.0.11:
    Packets: Sent = 4, Received = 4, Lost = 0 (0% loss),
    Approximate round trip times in milli-seconds:
        Minimum = 0ms, Maximum = 0ms, Average = 0ms

E:\Documents and Settings\Mahi>_

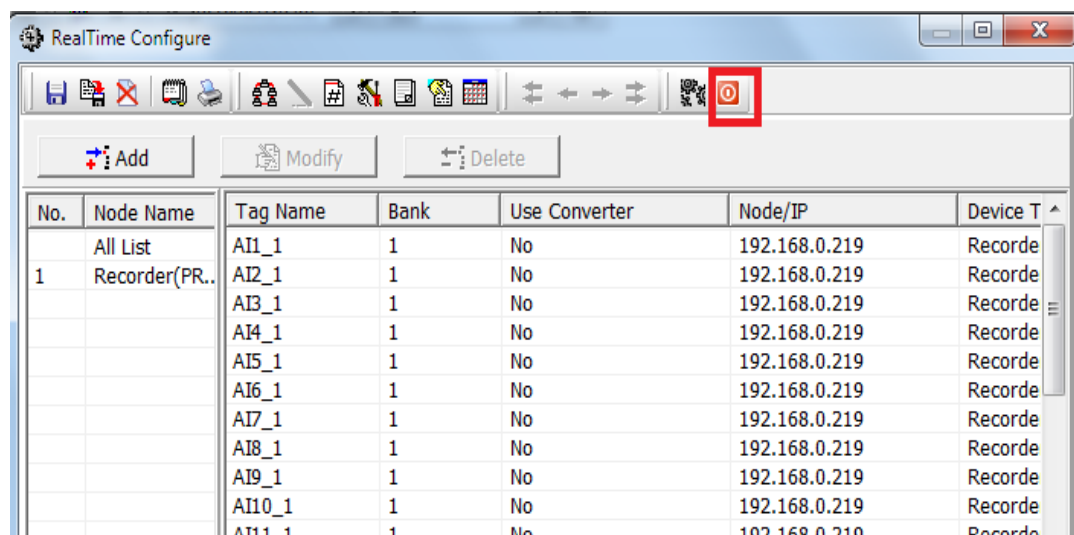
```

5. Double click at Realtime viewer icon  at desktop and follow on screen instructions to create a new WHOject

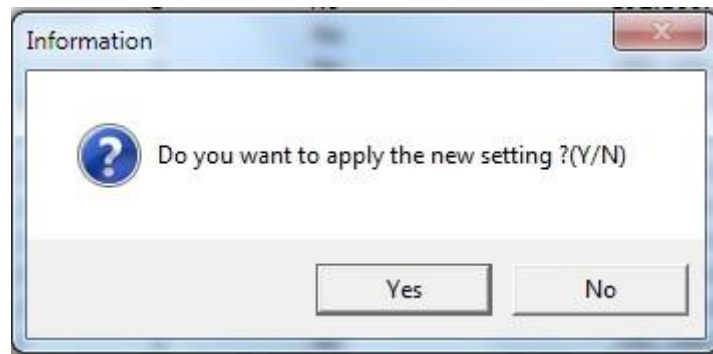
Note: Create a new WHOject only if it's first time. Next time onwards, you can open  the saved WHOject available in your computer



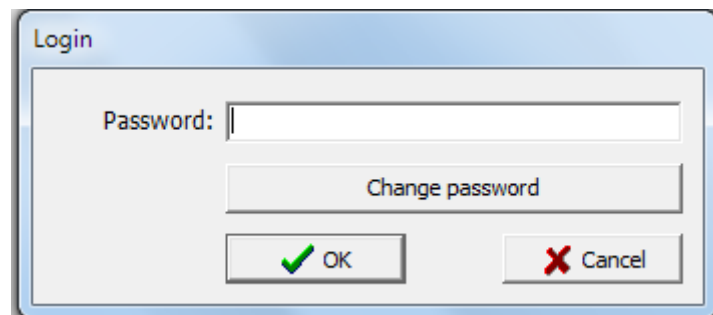
If the connection is working fine, the user can see the below figure. Upon clicking the icon shown you are accepting the configuration



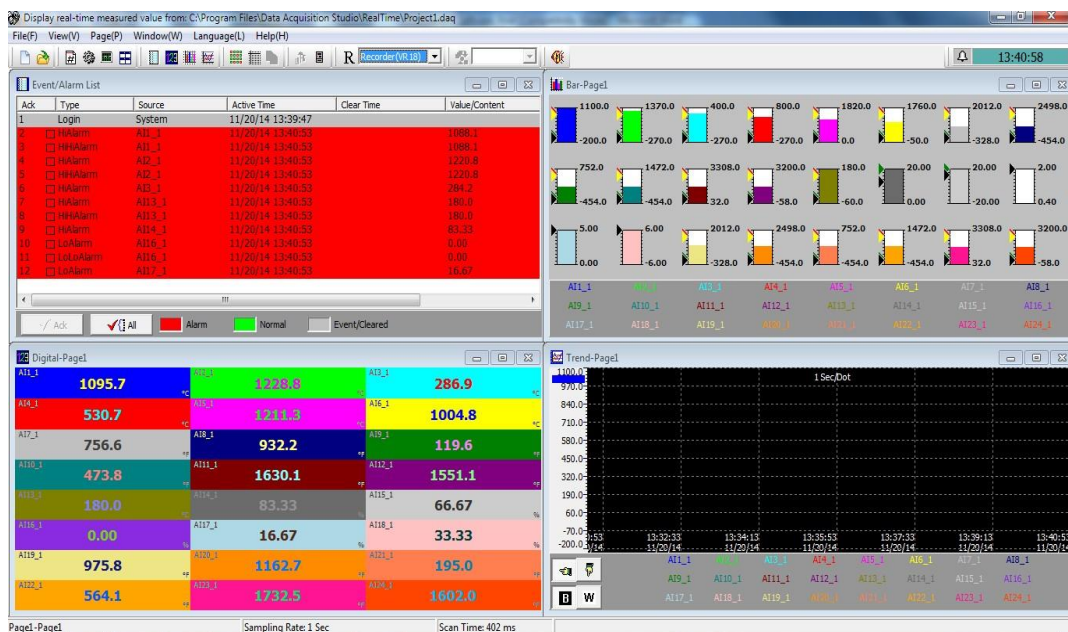
Click yes to apply the settings.



If you have set no password just click ok



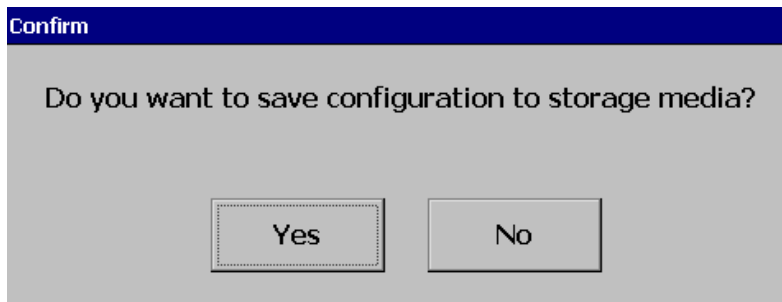
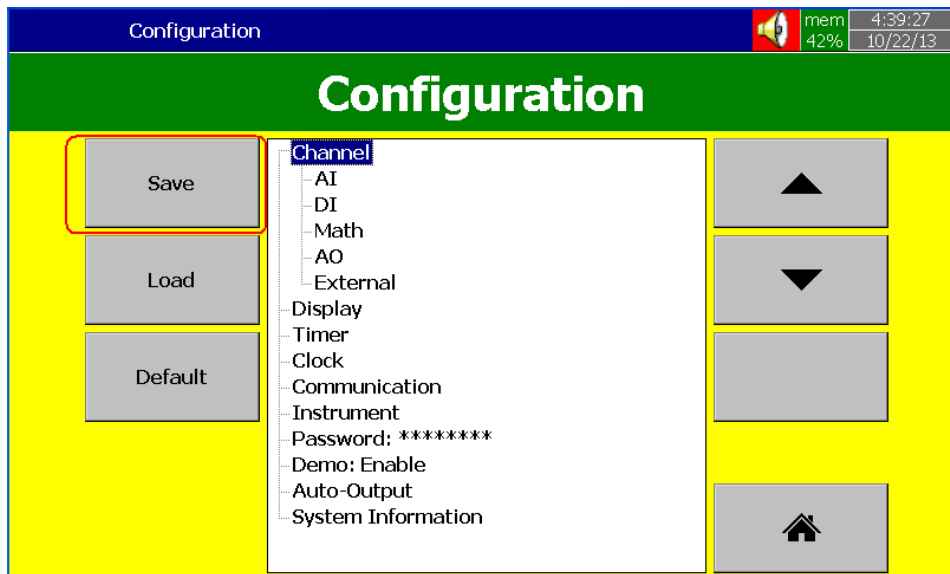
And after that you can see the below figure



## 5.2.8 Removable Media

The steps are given below

1. In Recorder, pl. insert empty SD card or USB stick
2. In Recorder, WHess “Menu-More-Config”. WHess “Save”




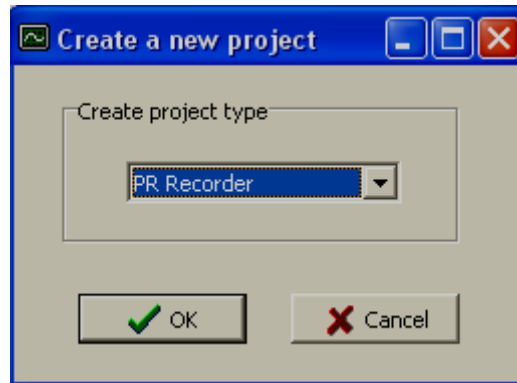
WHess “Yes”. It will save Recorder configuration files into USB stick.

Check contents of Removable media. It should have following files



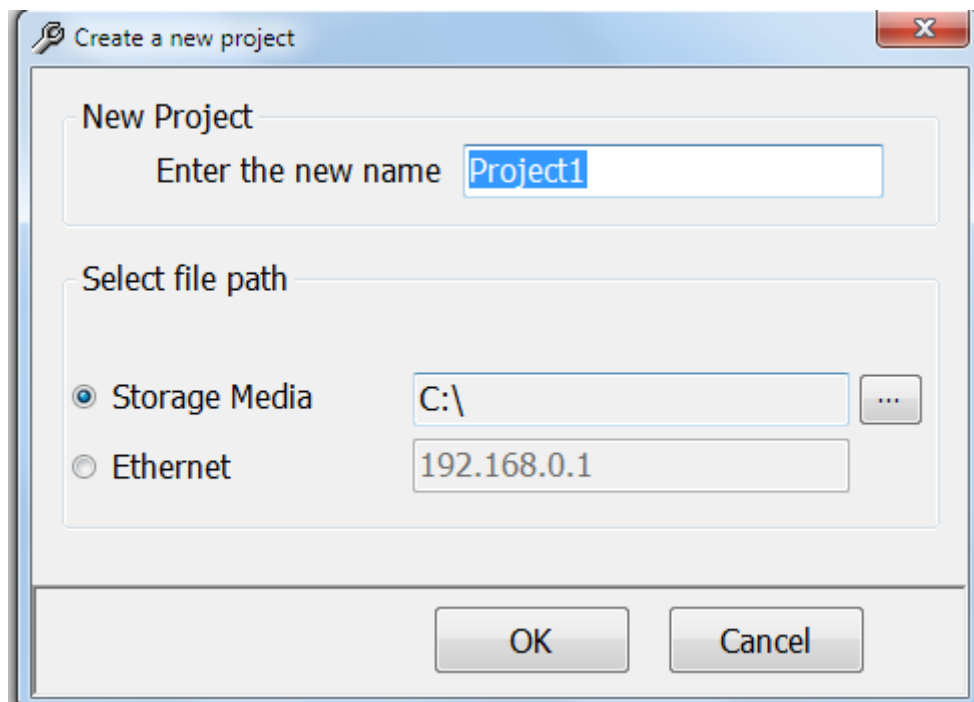
3. Remove Removable media from Recorder. Insert in PC

4. Double click at historical viewer icon  at desktop and follow on screen instructions to create a new WHOject

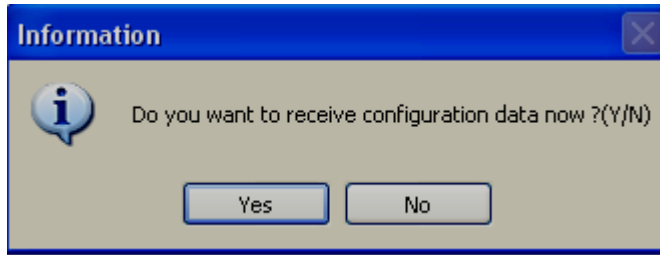


Select WH Recorder. Click “OK”

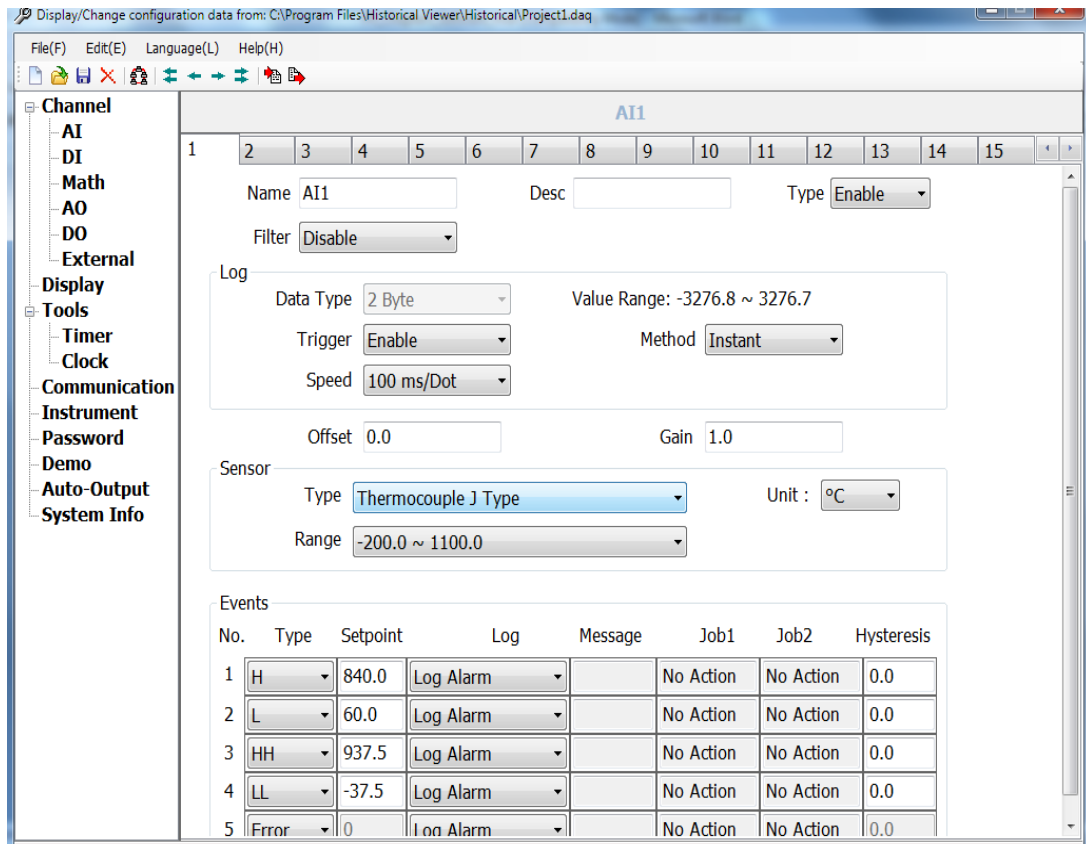
Note: Above screen appears first time if no WHOject files available in Computer




Select Storage Media, path to the Recorder files in USB stick or SD card and click “OK”

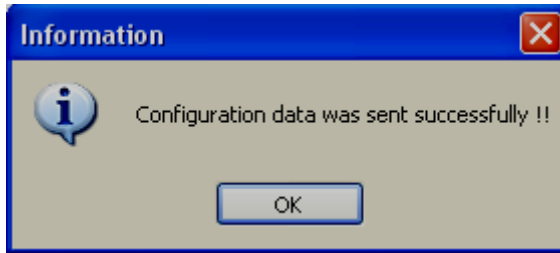


Click "Yes". It will open Recorder configuration screen



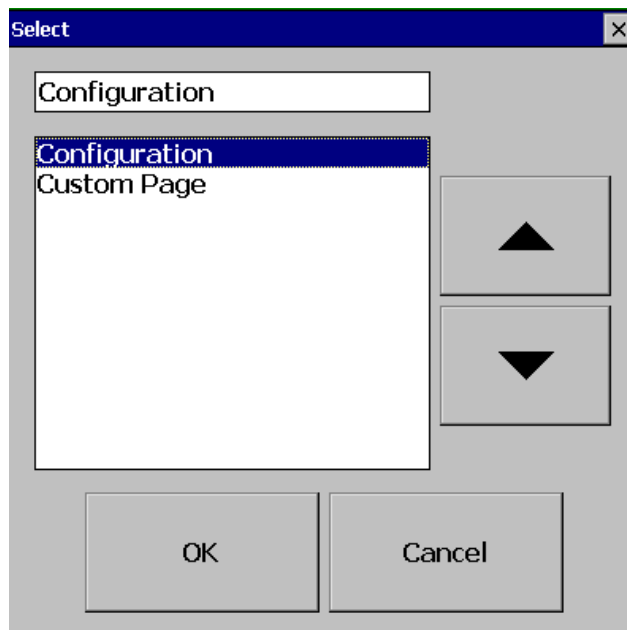
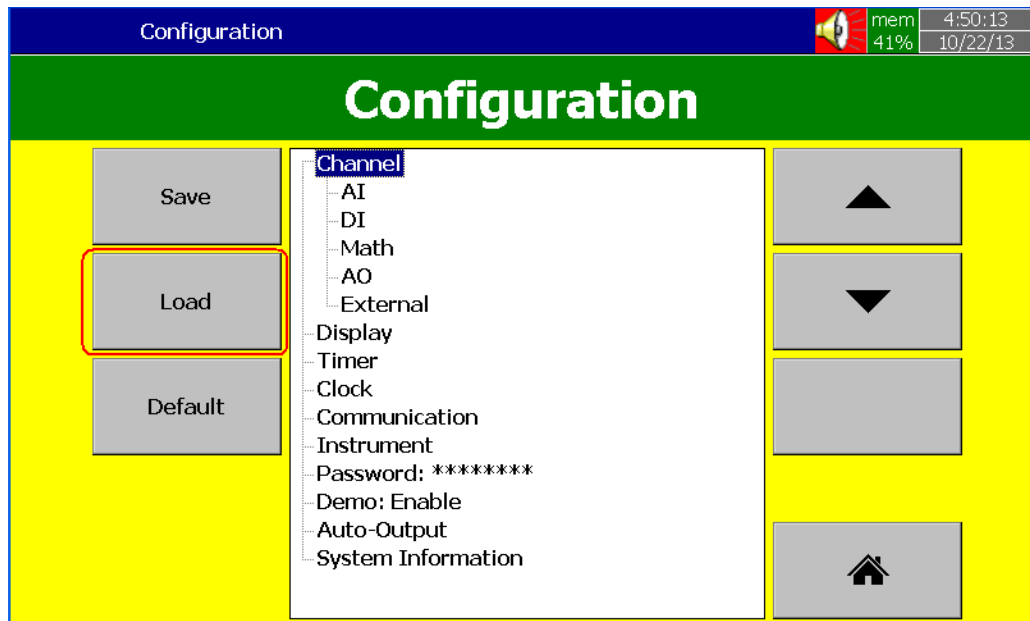
Note: The configuration screen is same as available directly in Recorder. Please refer Chapter 3 & 4 for more details about configuration

- Do the required changes in the configuration. Click at Send configuration icon 

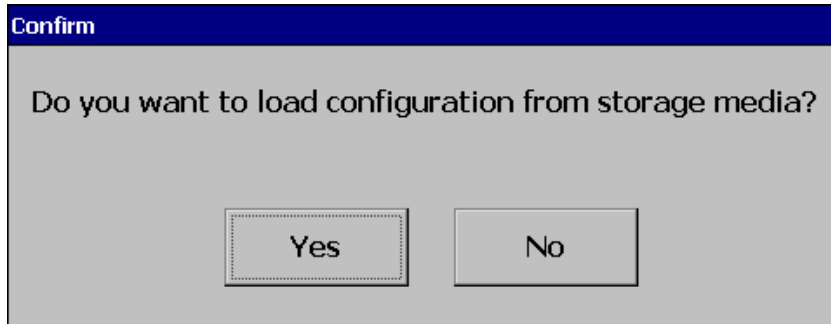


6. Now, remove Removable media from PC. Insert it into the Recorder. In Recorder, WHess "Menu-More-Config"

WHess "Load"



WHess "OK"



When "Yes"

## 5.2.9 Configuration

Please refer Chapter 4 for full details related to configuration

### 5.2.9.1 Analog Input

- Channel
- AI
- DI
- Math
- AO
- DO
- External
- Display
- Tools
- Timer
- Clock
- Communication
- Instrument
- Password
- Demo
- Auto-Output
- System Info

AI1

1	2	3	4	5	6	7	8	9	10	11	12	13	14	15	
Name		AI1					Desc			Type					Enable

Filter: Disable

Log

Data Type: 2 Byte      Value Range: -3276.8 ~ 3276.7

Trigger: Enable      Method: Instant

Speed: 100 ms/Dot

Offset: 0.0      Gain: 1.0

Sensor

Type: Thermocouple J Type      Unit: °C

Range: -200.0 ~ 1100.0

Events

No.	Type	Setpoint	Log	Message	Job1	Job2	Hysteresis
1	<span style="border: 1px solid gray; padding: 2px;">H</span>	840.0	<span style="border: 1px solid gray; padding: 2px;">Log Alarm</span>		No Action	No Action	0.0
2	<span style="border: 1px solid gray; padding: 2px;">L</span>	60.0	<span style="border: 1px solid gray; padding: 2px;">Log Alarm</span>		No Action	No Action	0.0
3	<span style="border: 1px solid gray; padding: 2px;">HH</span>	937.5	<span style="border: 1px solid gray; padding: 2px;">Log Alarm</span>		No Action	No Action	0.0
4	<span style="border: 1px solid gray; padding: 2px;">LL</span>	-37.5	<span style="border: 1px solid gray; padding: 2px;">Log Alarm</span>		No Action	No Action	0.0
5	<span style="border: 1px solid gray; padding: 2px;">Error</span>	0.0	<span style="border: 1px solid gray; padding: 2px;">Log Alarm</span>		No Action	No Action	0.0

### 5.2.9.2 Digital Input

**DI1**

1 2 3 4

Name: DI1  
 Desc: Tank level high  
 Type: Logic Level

**Events**

No.	Type	Log	Message	Job1	Job2
1	Disab	No Action		No Action	No Action
2	Disab	No Action		No Action	No Action

### 5.2.9.3 Math channel

**Math1**

1 2 3 4 5 6 7 8 9 10 11 12

Name: Math1  
 Desc: Totalizer 6  
 Type: Math

**Log**

Data Type: 4 Byte Value Range: -3.4E+38 ~ 3.4E+38  
 Trigger: Enable Method: Instant  
 Speed: 100 ms/Dot

Expression: (AI1+AI2)/2

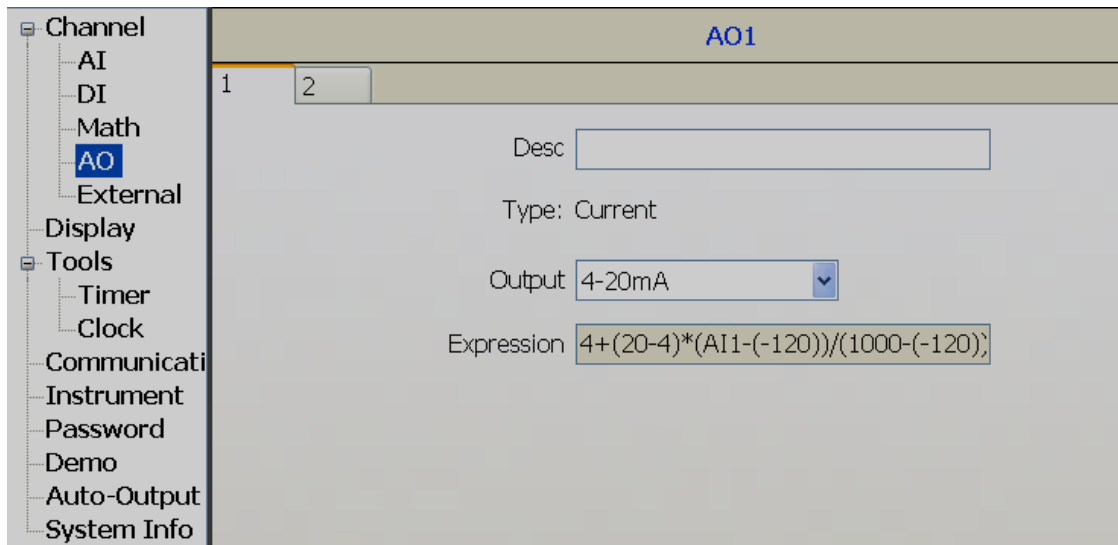
**Scale**

Unit: Transformation: Value  
 Decimal: 0 Table: Point 1 to 2  
 Range: 0 ~ 10

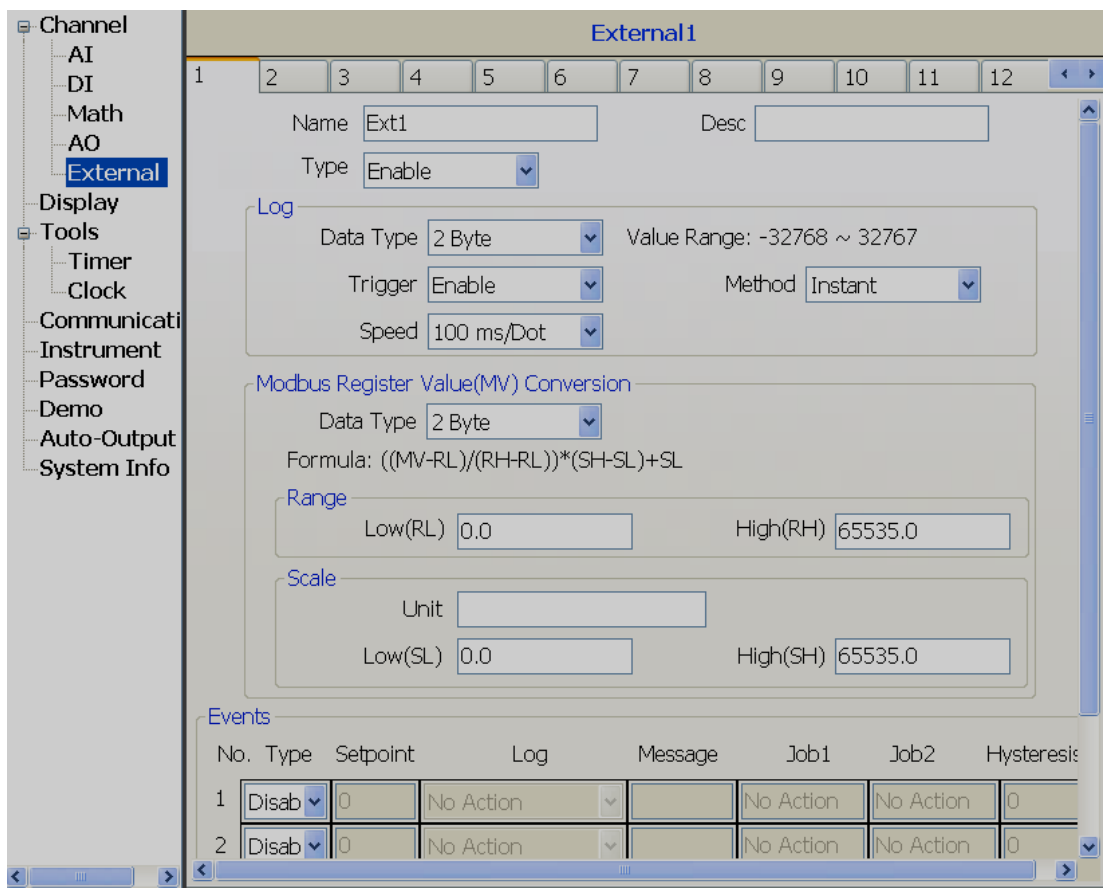
**Events**

No.	Type	Setpoint	Log	Message	Job1	Job2	Hysteresis
1	H	0	No Action		No Action	No Action	0
2	Disab	0	No Action		No Action	No Action	0
3	Disab	0	No Action		No Action	No Action	0
4	Disab	0	No Action		No Action	No Action	0
5	Disab	0	No Action		No Action	No Action	0

### 5.2.9.4 Analog Output



### 5.2.9.5 External Channel



### 5.2.9.6 Display

**Display1**

Name: Page1    Mode: Trend    Direction: Horizontal

Speed: 1 Sec/Dot    Background: Black

Pen					
No.	Channel	Color	Width	Display Low	Display High
1	AI1	Blue	1	-120.0	1000.0
2	AI2	Lime	1	-200.0	1370.0
3	AI3	Cyan	1	-250.0	400.0
4	AI4	Red	1	-100.0	900.0
5	AI5	Magenta	1	0.0	1820.0
6	AI6	Yellow	1	0.0	1767.8
7	AI7	Gray	1	0.0	1767.8
8	AI8	Dark Blue	1	-250.0	1300.0

**Status Bar**

Type: Disable

1. Disable    2. Disable    3. Disable    4. Disable  
5. Disable    6. Disable    7. Disable    8. Disable

### 5.2.9.7 Timer

**Timer1**

Type: Daily    Action: Enable

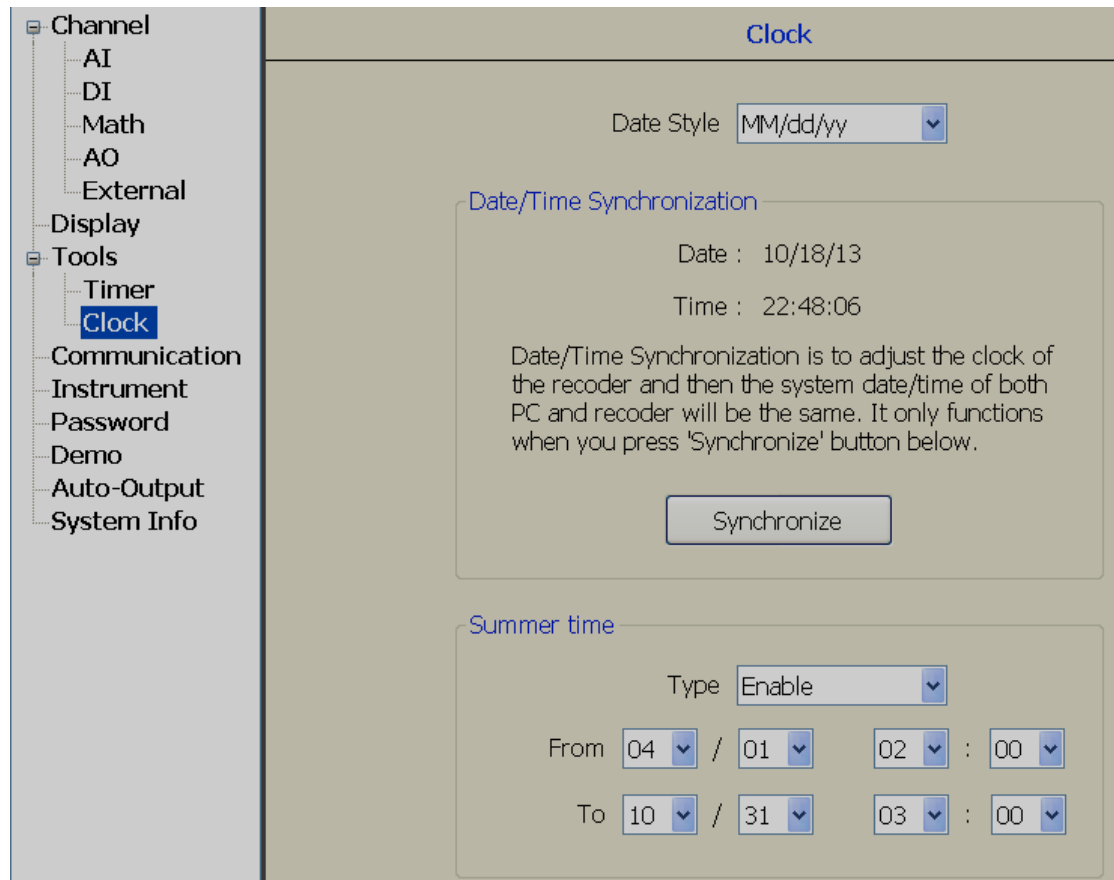
**Time**

Day: 1    Hour: 8    Min: 0    Sec: 1

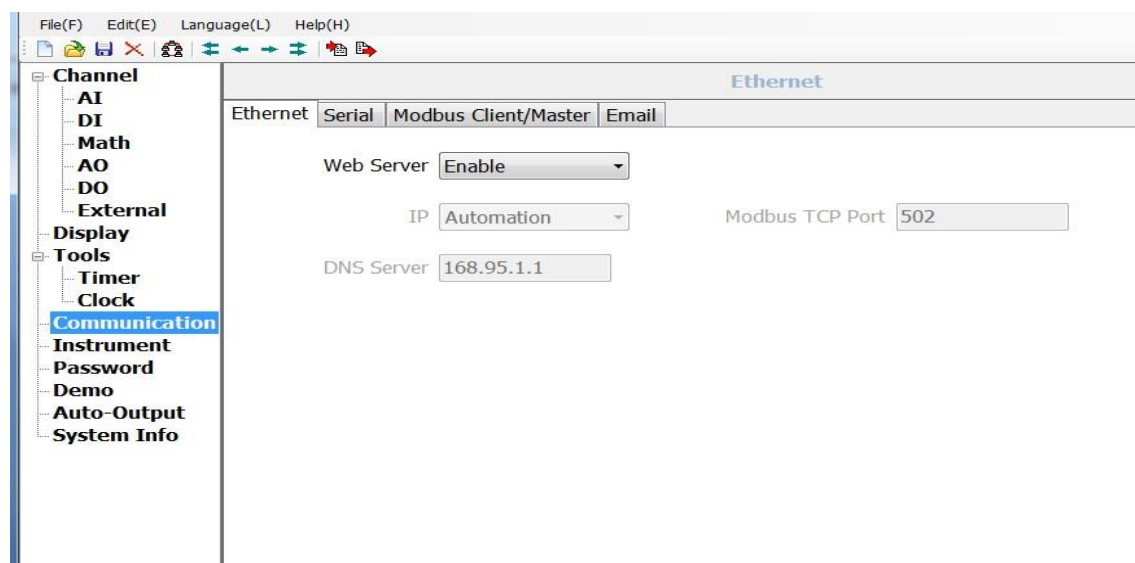
**Events**

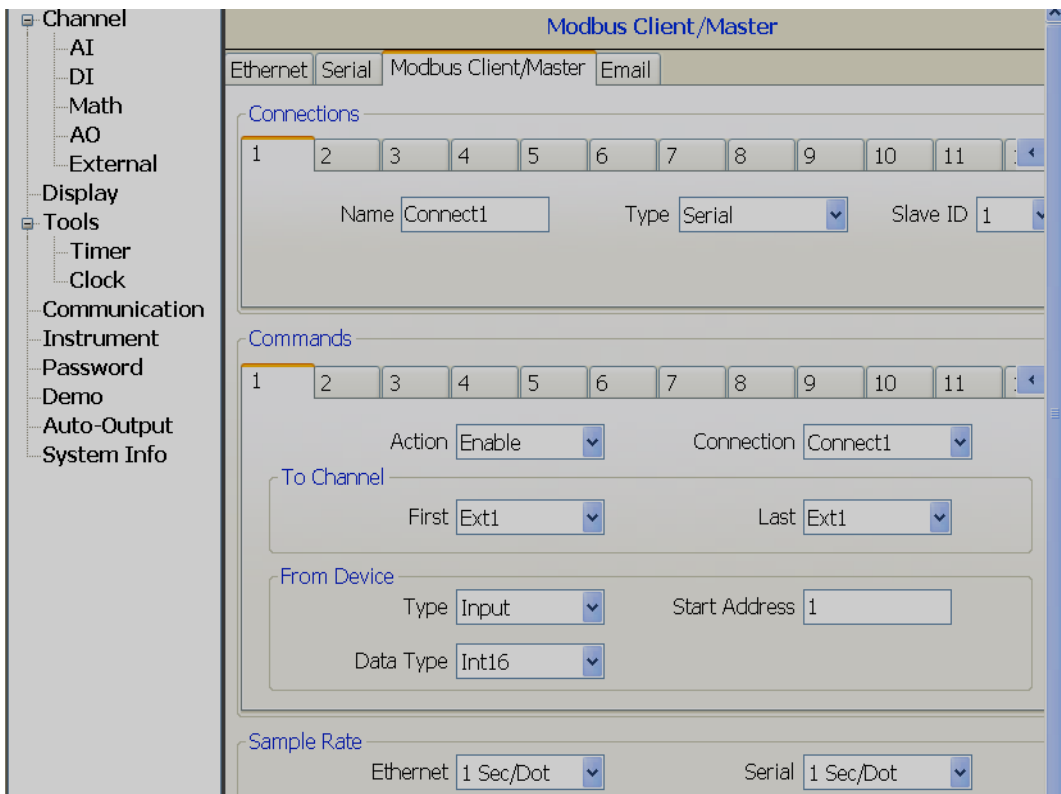
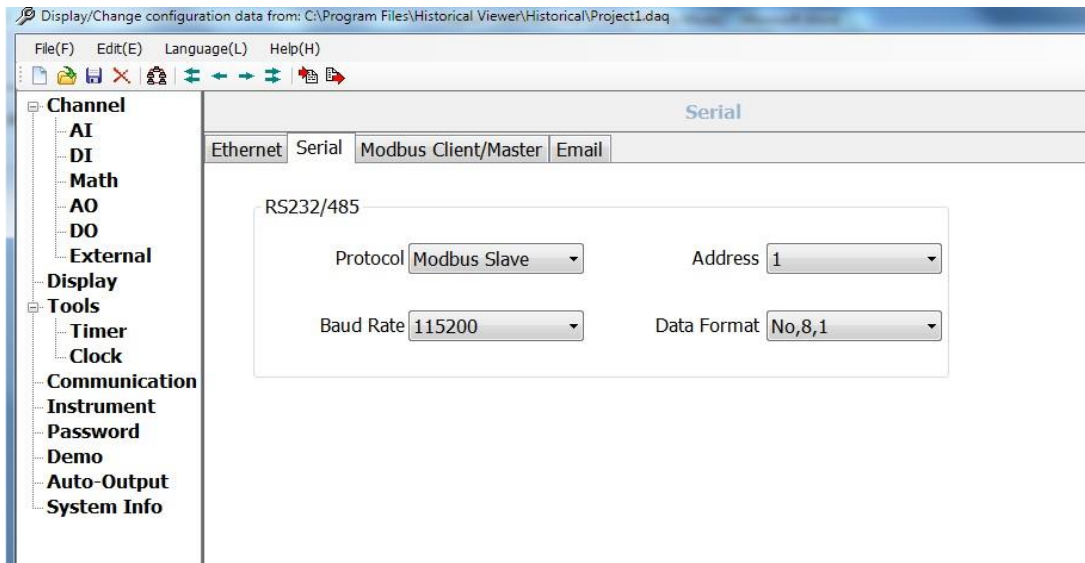
Job1: Print Report List  
Job2: No Action

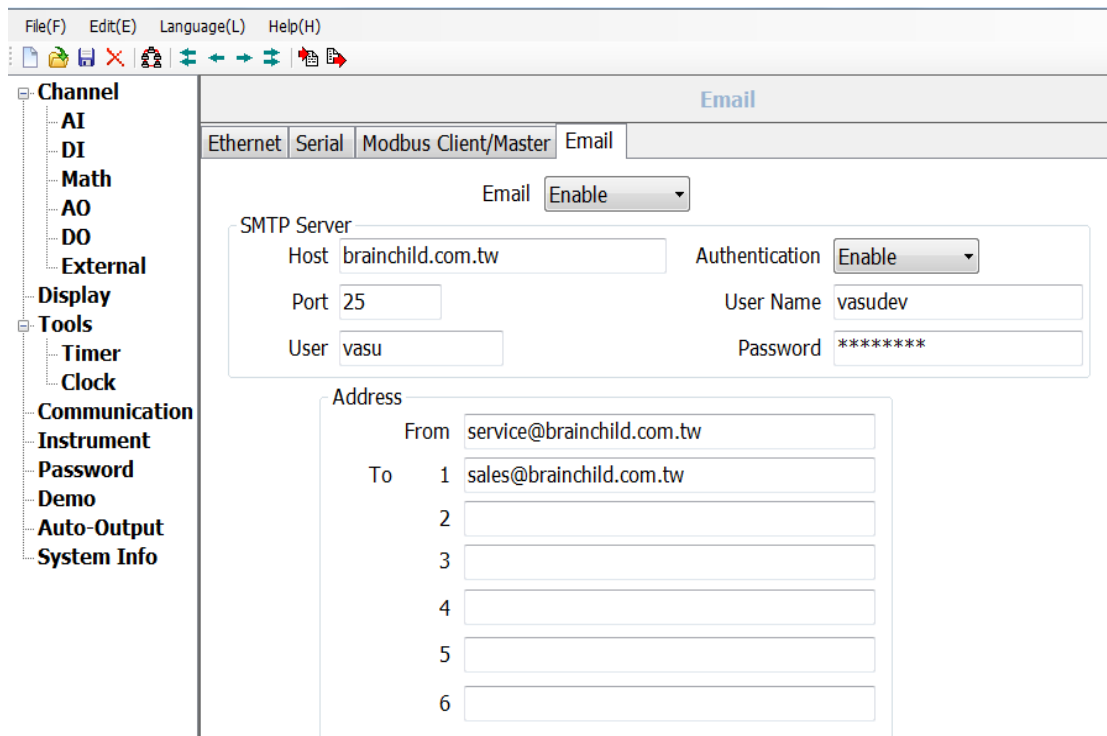
### 5.2.9.8 Clock



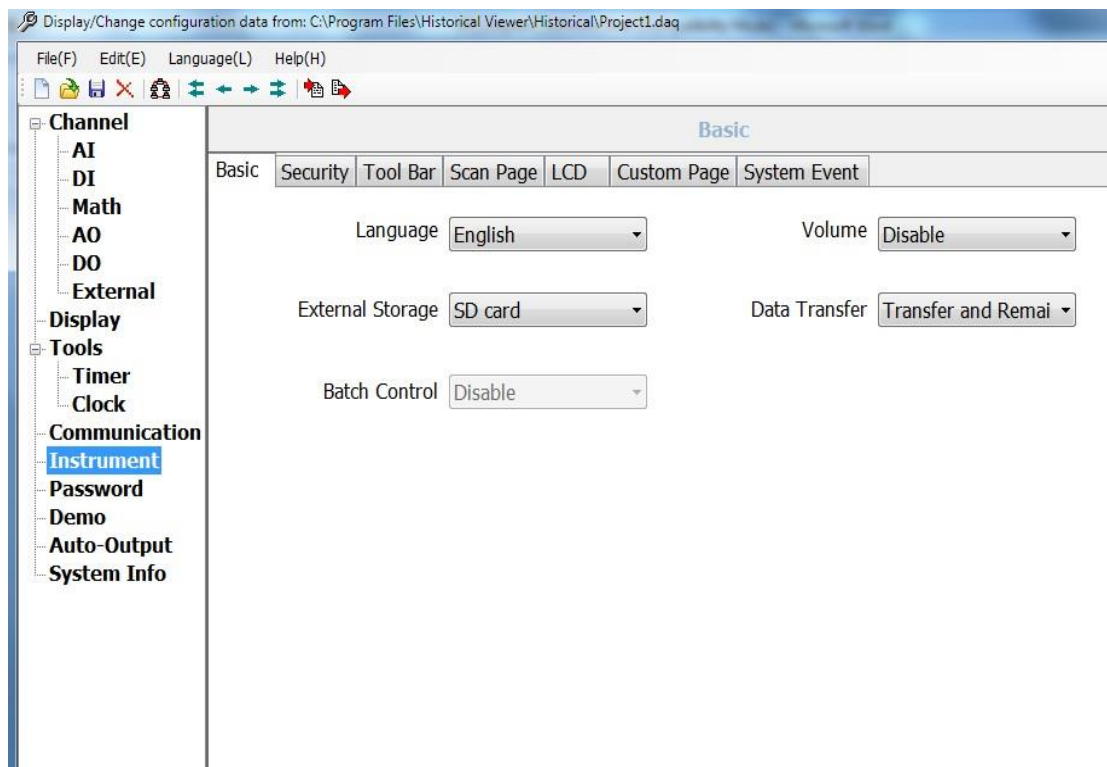
### 5.2.9.9 Communication

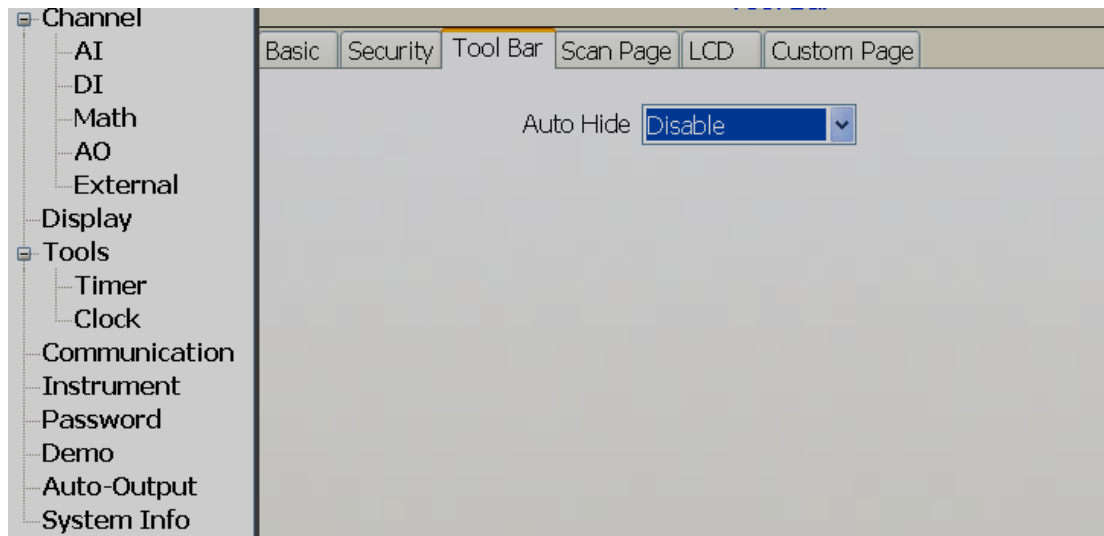
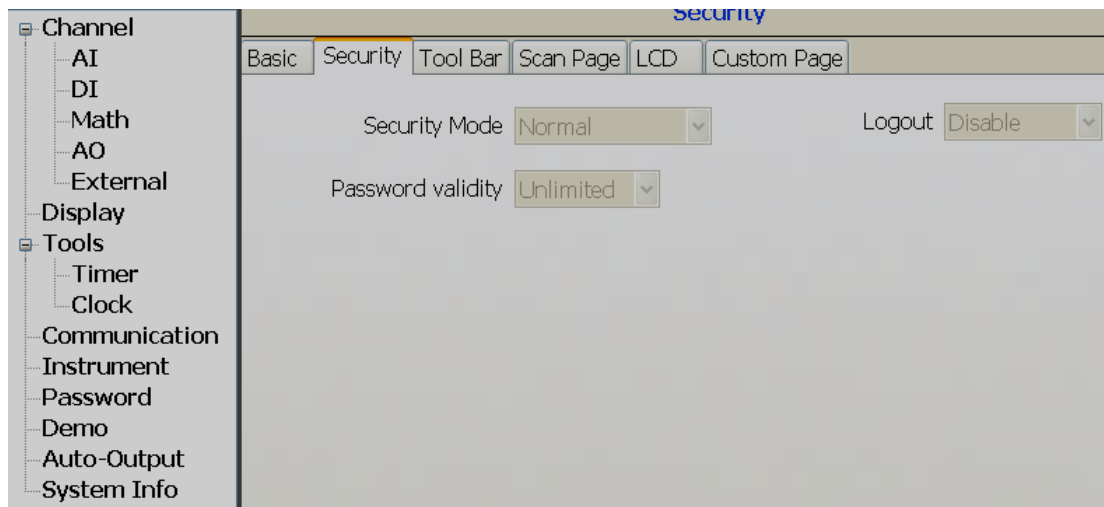


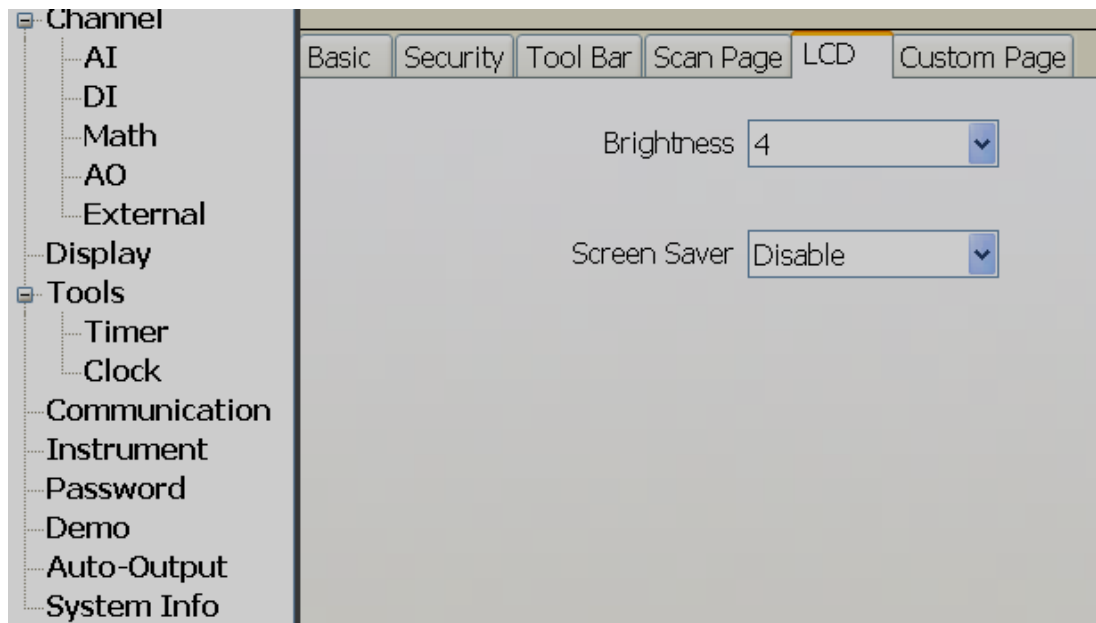
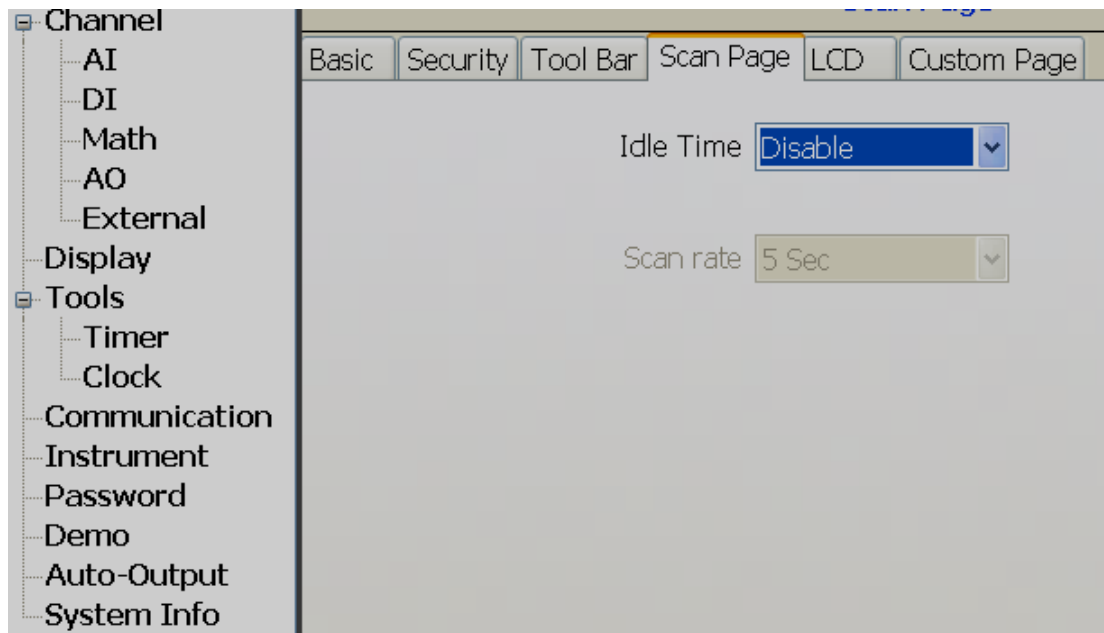


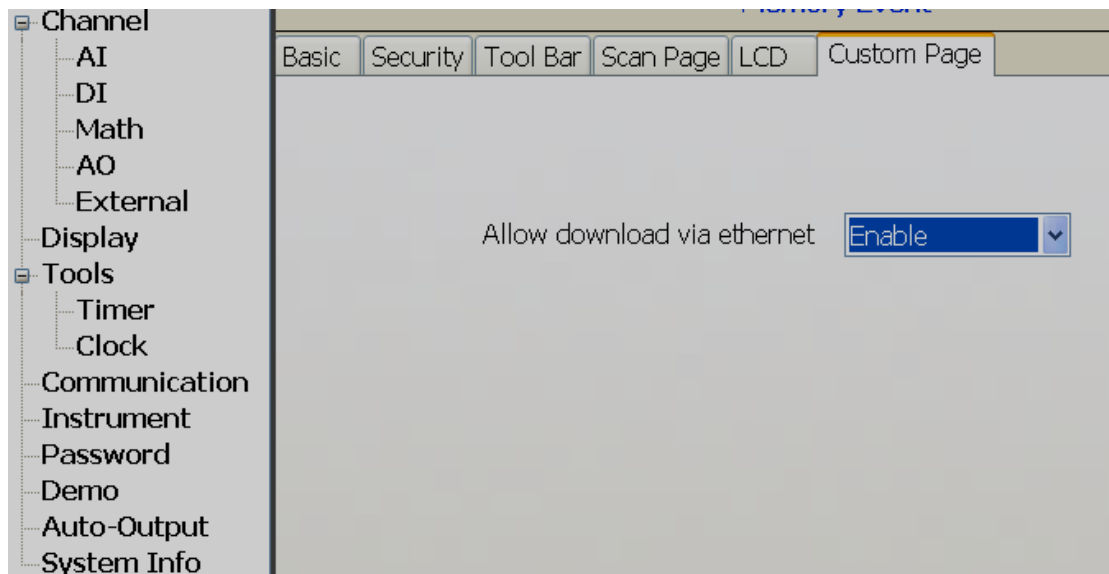


### 5.2.9.10 Instrument

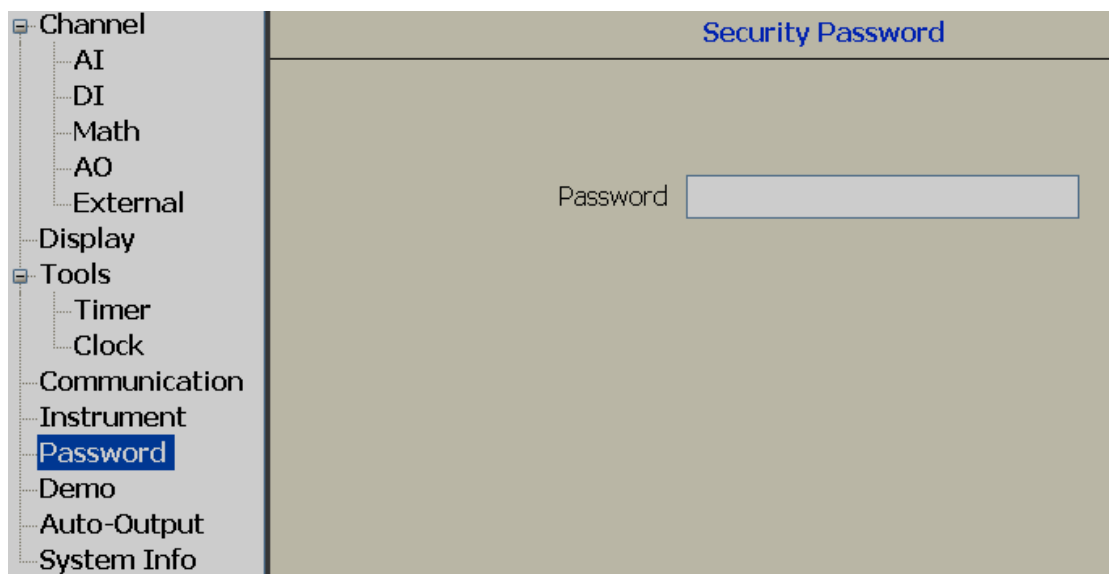




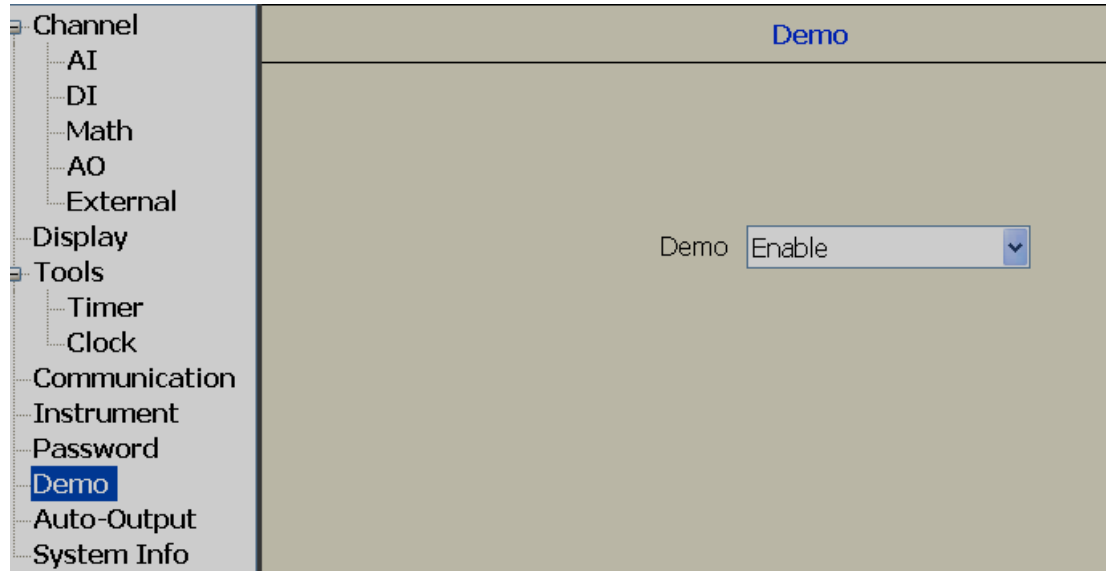




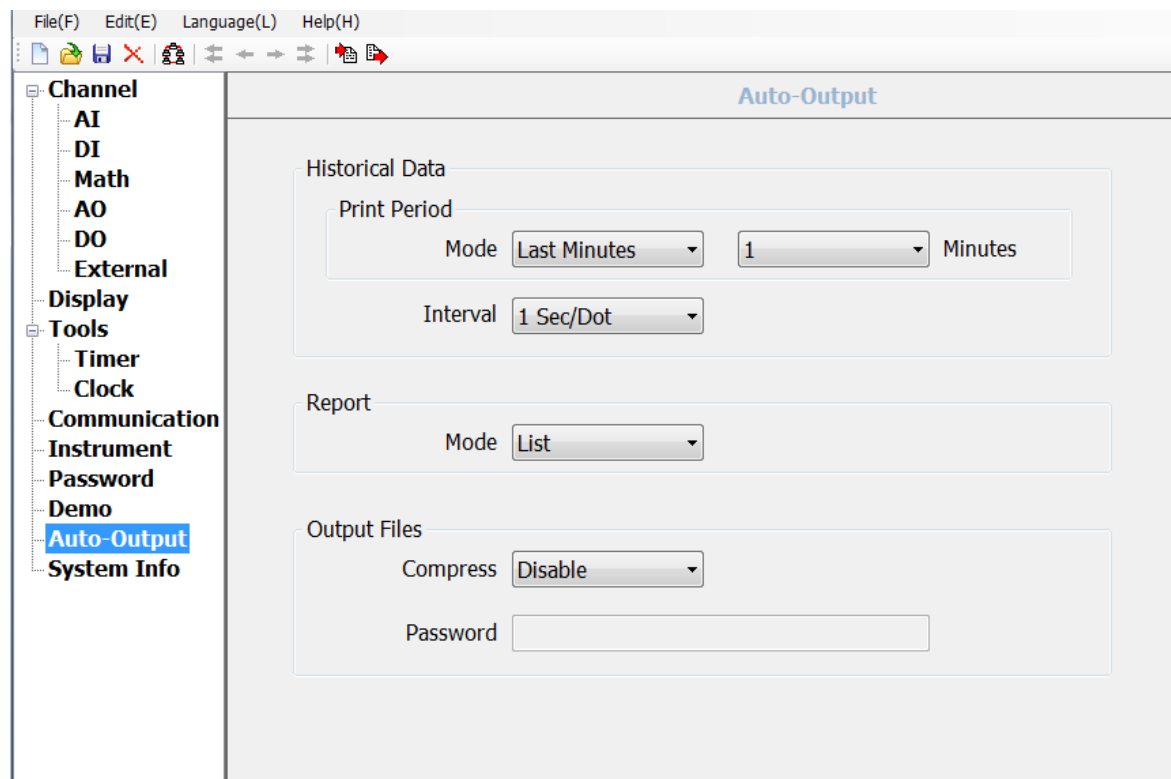
### 5.2.9.11 Password



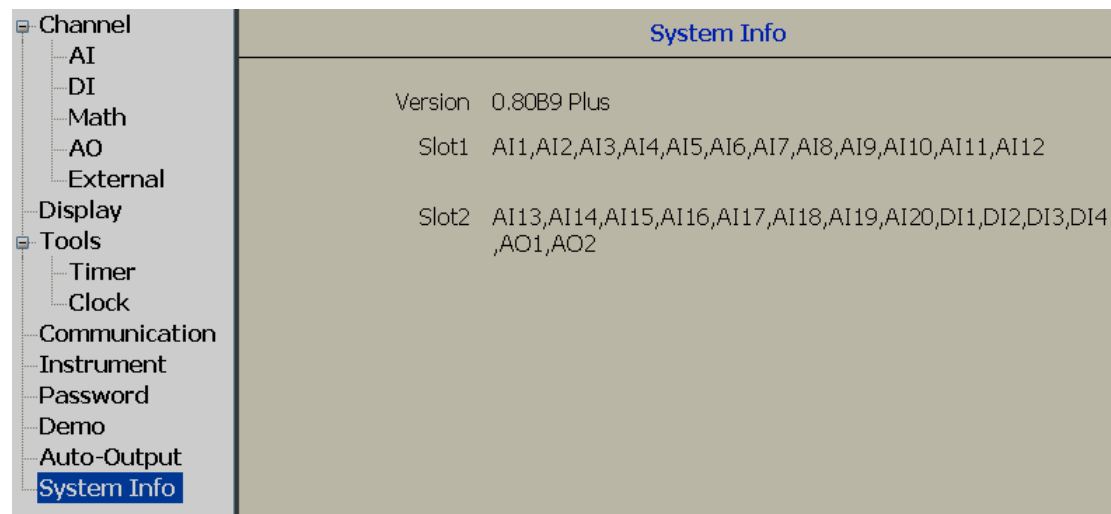
### 5.2.9.12 Demo



### 5.2.9.13 Auto-Output



### 5.2.9.14 System Information



System Info	
Version	0.80B9 Plus
Slot1	AI1,AI2,AI3,AI4,AI5,AI6,AI7,AI8,AI9,AI10,AI11,AI12
Slot2	AI13,AI14,AI15,AI16,AI17,AI18,AI19,AI20,DI1,DI2,DI3,DI4, AO1,AO2

### 5.2.10 How to view Historical data

Three ways

1. Touch screen
2. Ethernet
3. USB stick

#### 5.2.10.1 Touch Screen

Please refer Chapter 3 for details how to view historical data in Recorder directly using the Touch screen


#### 5.2.10.2 Ethernet

Note: Please read the following sections first

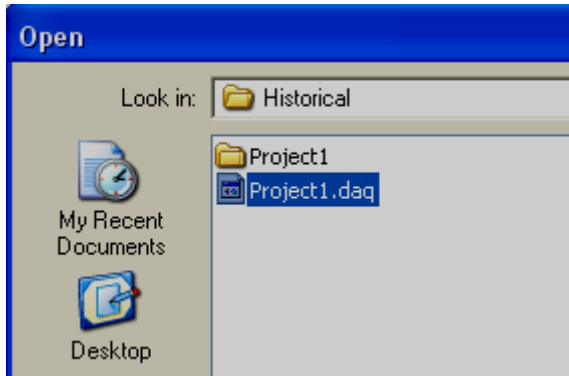
1. How to configure Communication bank
2. How to configure Recorder - Ethernet

Make sure, WHOject already created and it's saved in Computer, set bank WHoperly to Ethernet before WHOceeding with the below steps

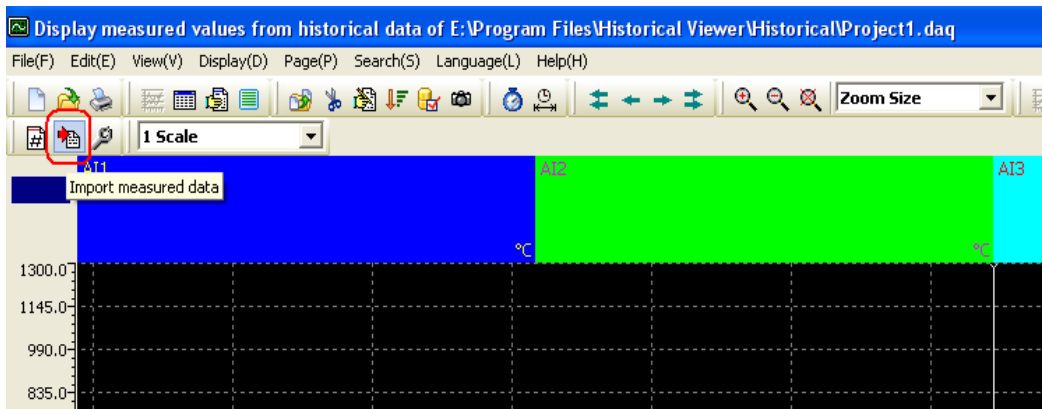
Open WHOject from Historical viewer using one of the following options


Desktop: Historical viewer icon 

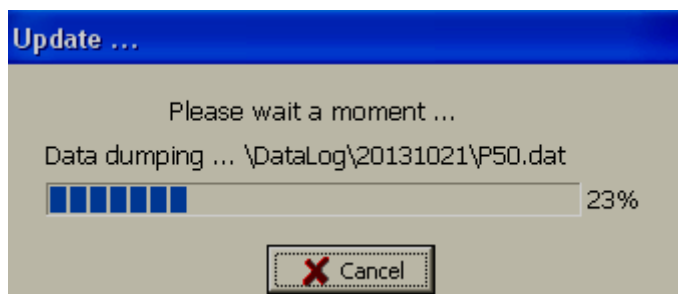
Start-WHograms-Historical viewer-Historical viewer



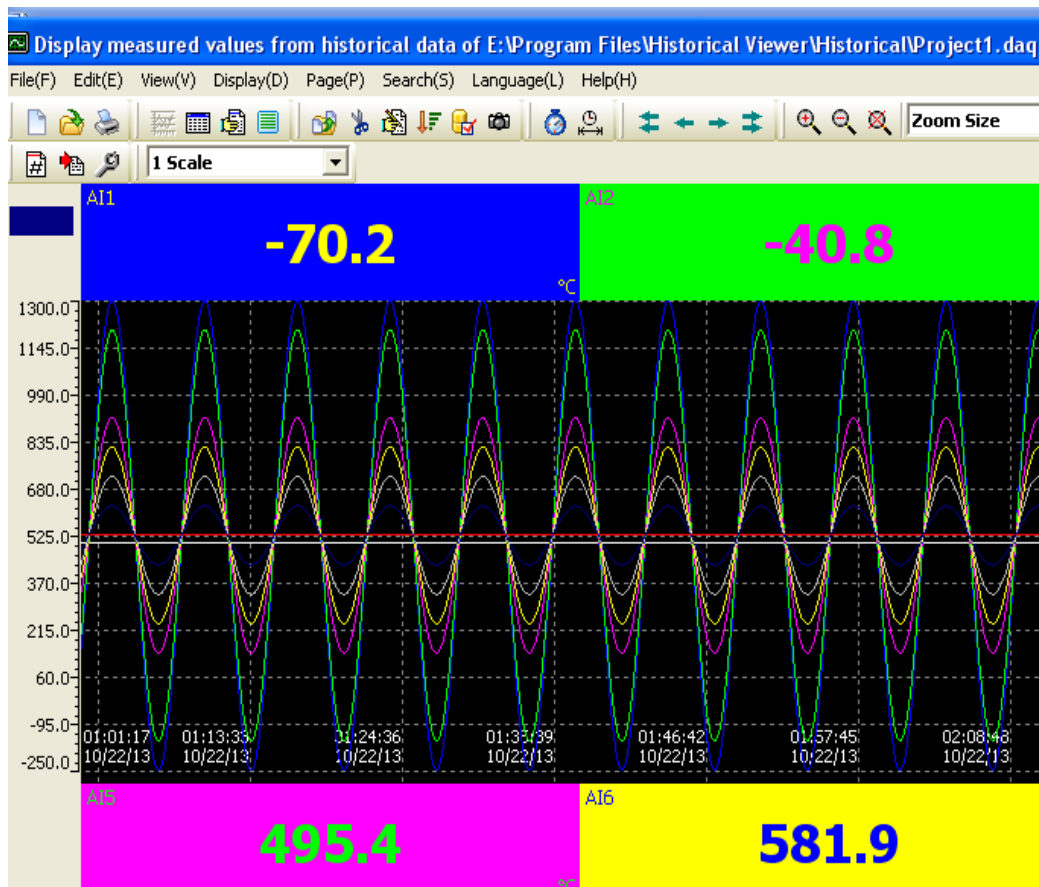
Select WHOject and click “Open”




Click Import measured data icon 



Note: Time taken based on amount of data available in internal memory



Select on any of the trend area, then click at Zoom icon  and then see the historical trend clearly

Note: Please read “Historical viewer” help file from software itself for all the features available in Historical viewer software

### 5.2.10.3 Removable Media

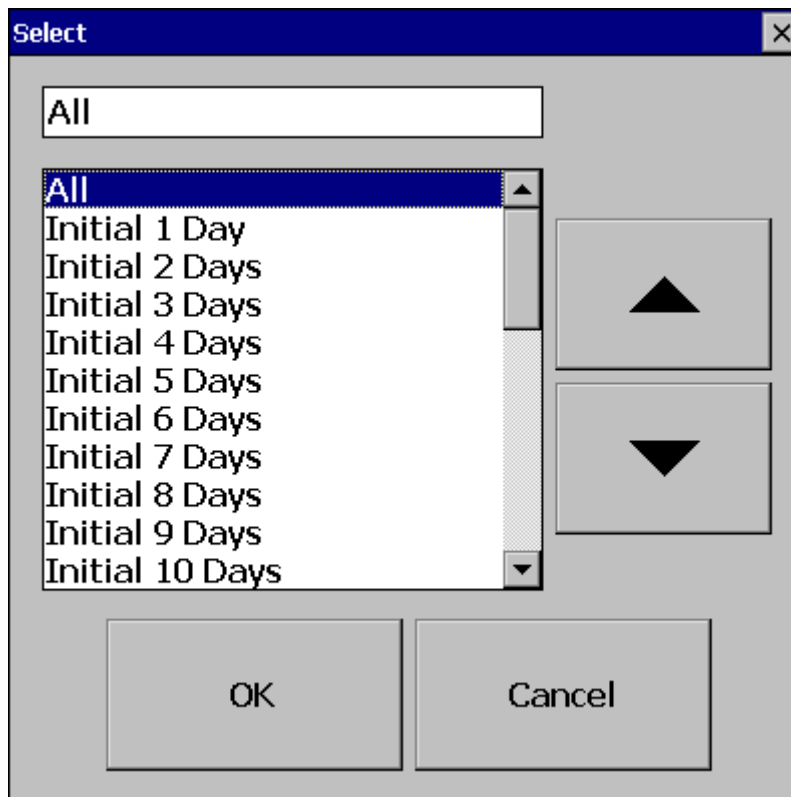
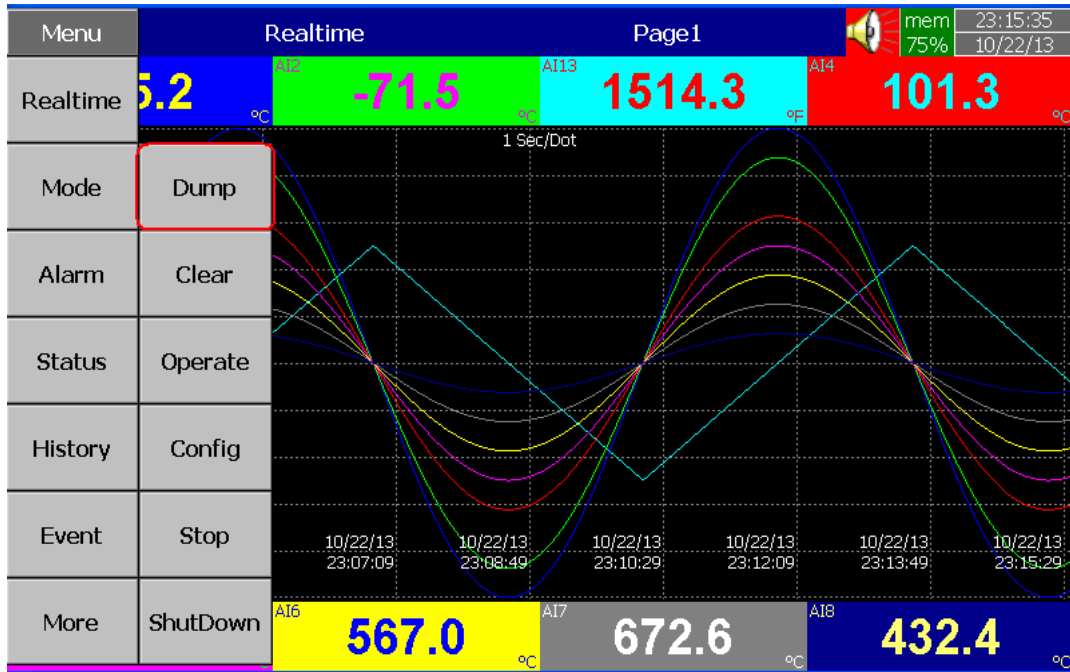
Note: Please read the following sections first

1. How to configure Communication bank
2. How to configure Recorder - SD card or USB

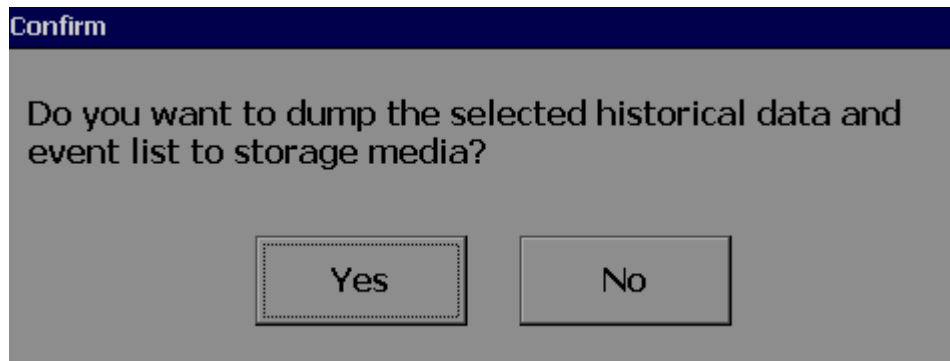
Make sure, WHOject already created via SD card or USB, it's saved in Computer, set bank WHOject to “Storage media” before WHOjecting with the below steps

Insert Empty - SD card or USB in Recorder

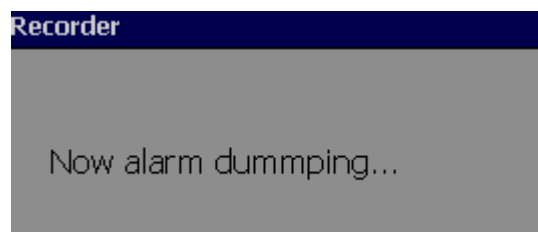
WHOject “Menu-More-Dump”



Select "All" or one of the other available options, then WHess "OK"

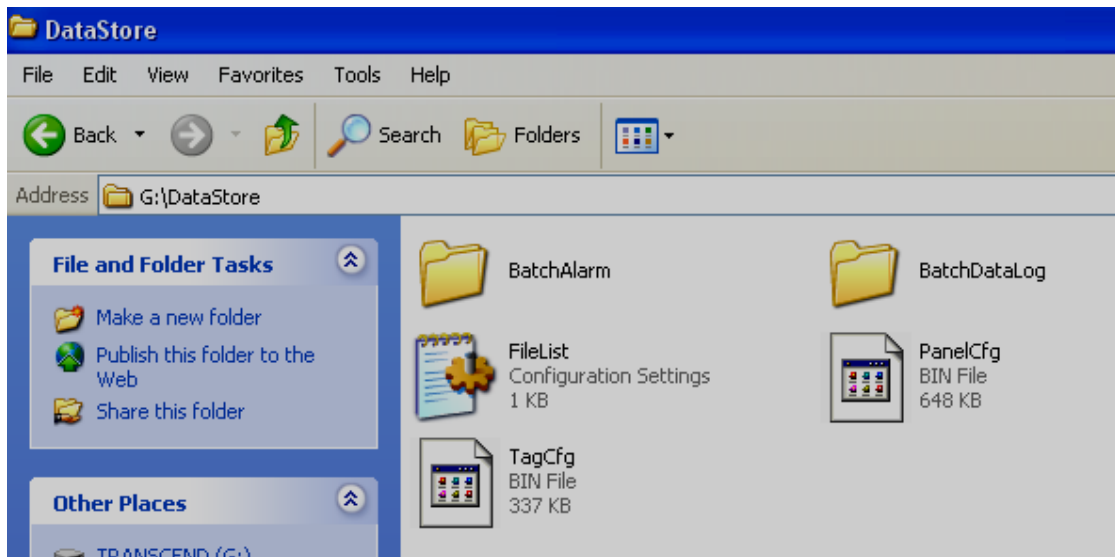


When "Yes"




Now, remove USB stick from Recorder

Check contents in the USB stick



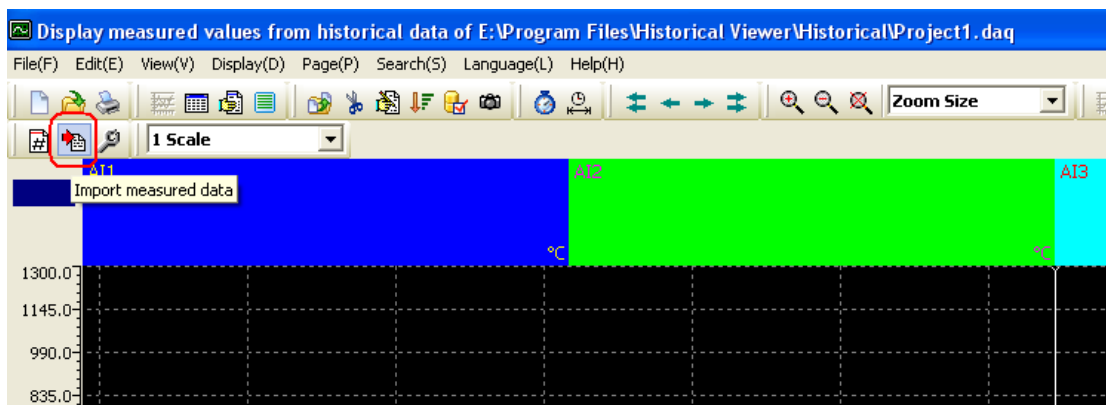
Open WHOject from Historical viewer using one of the following options


Desktop: Historical viewer icon 

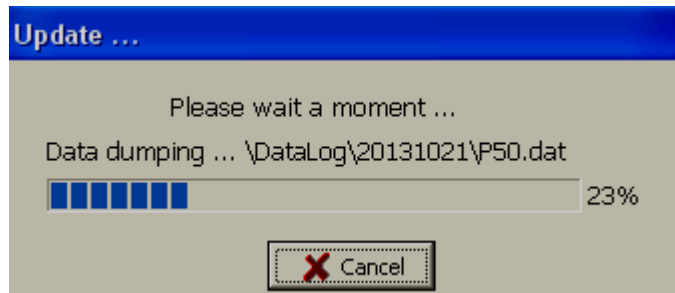
Start-WHograms-Historical viewer-Historical viewer



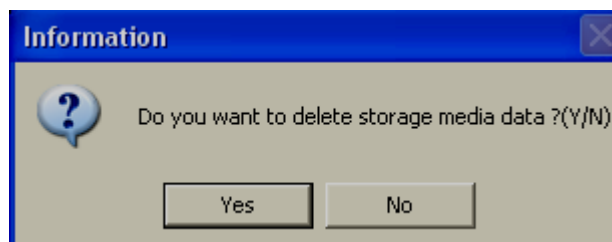
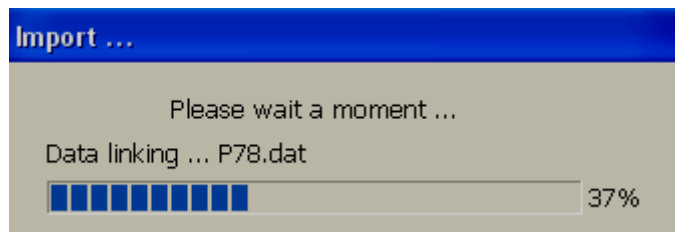
Select WHOject and click “Open”



Click Import measured data icon 

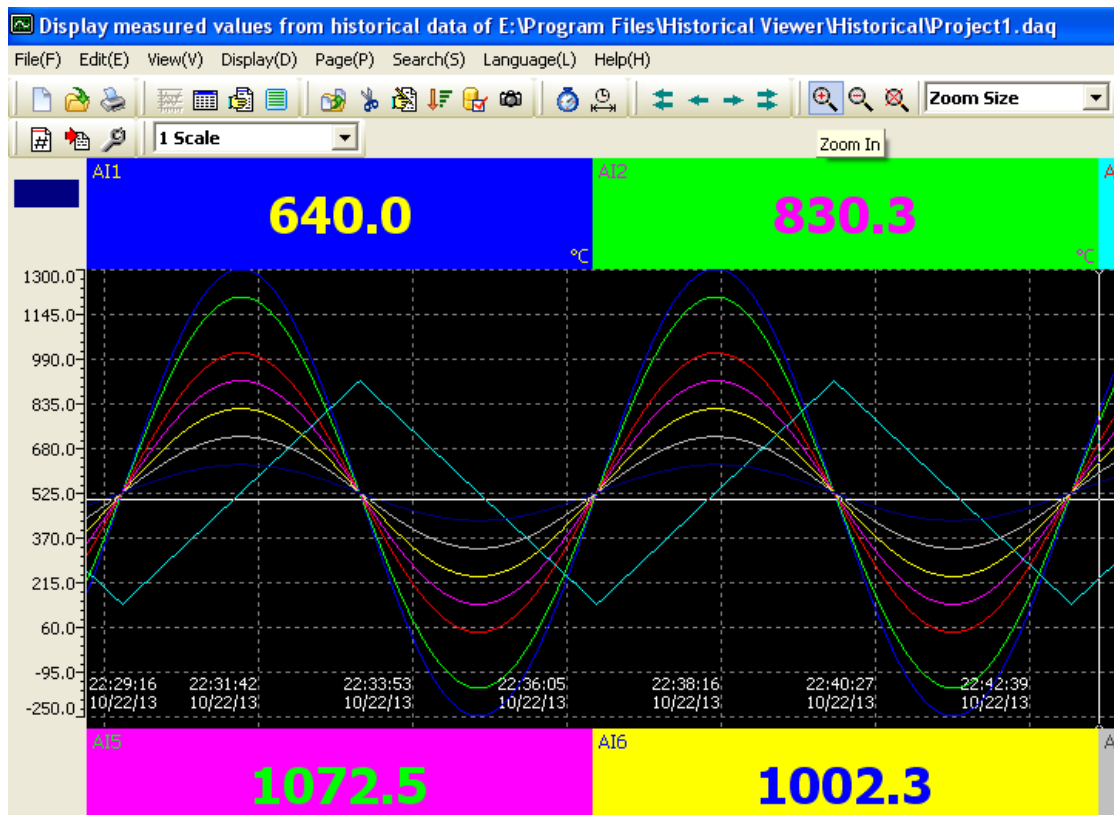



Note: Time taken based on amount of data available in internal memory



“Select” Yes if you wish to delete data from USB stick.

“Select” No only if any plans to transfer data say another Computer or if you have any plans to maintain data storage as back up in WHoWHietary format in Computer hard disk



Select on any of the trend area, then click at Zoom icon  and then see the historical trend clearly

Note: Please read “Historical viewer” help file from software itself for all the features available in Historical viewer software

### 5.2.11 How to view Real time data in PC


It is possible to monitor Real time data from Paperless Recorder in PC

For this, Recorder should be connected to PC via Ethernet or Serial network (RS232/422/485). Set bank WHoperly to WHOceed with required option

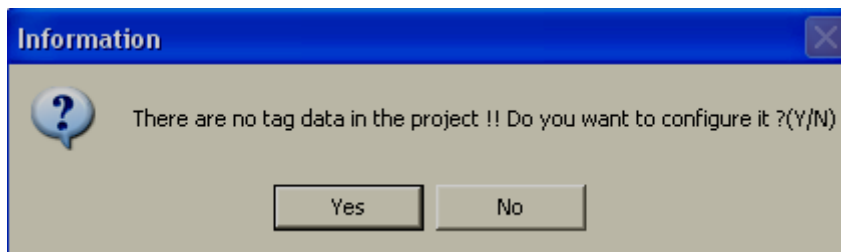
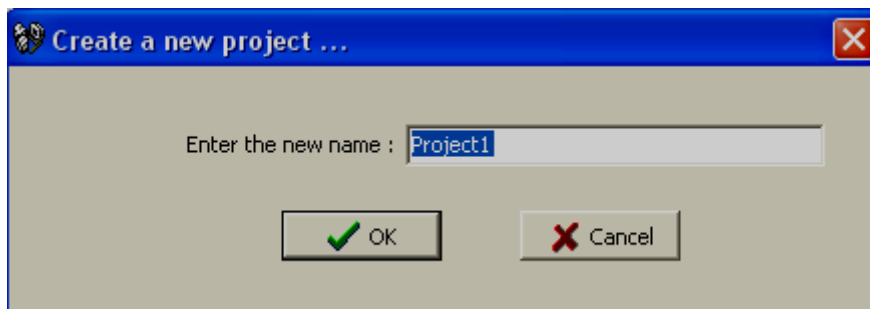
## 5.2.12 Bank configuration

How to open Real time viewer

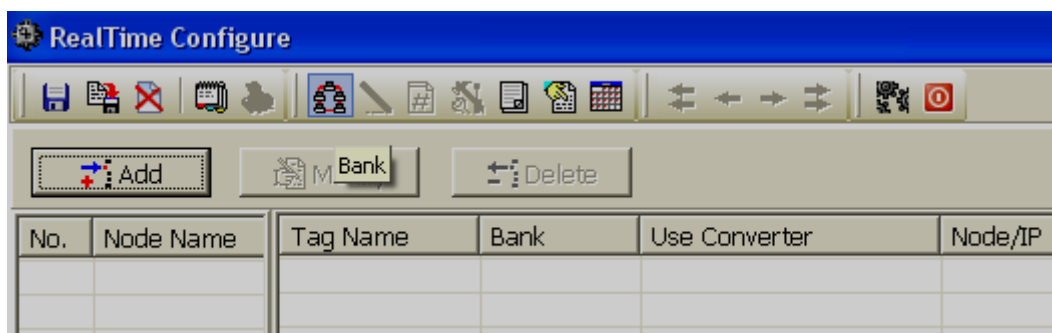
Two ways


Click at desktop icon 

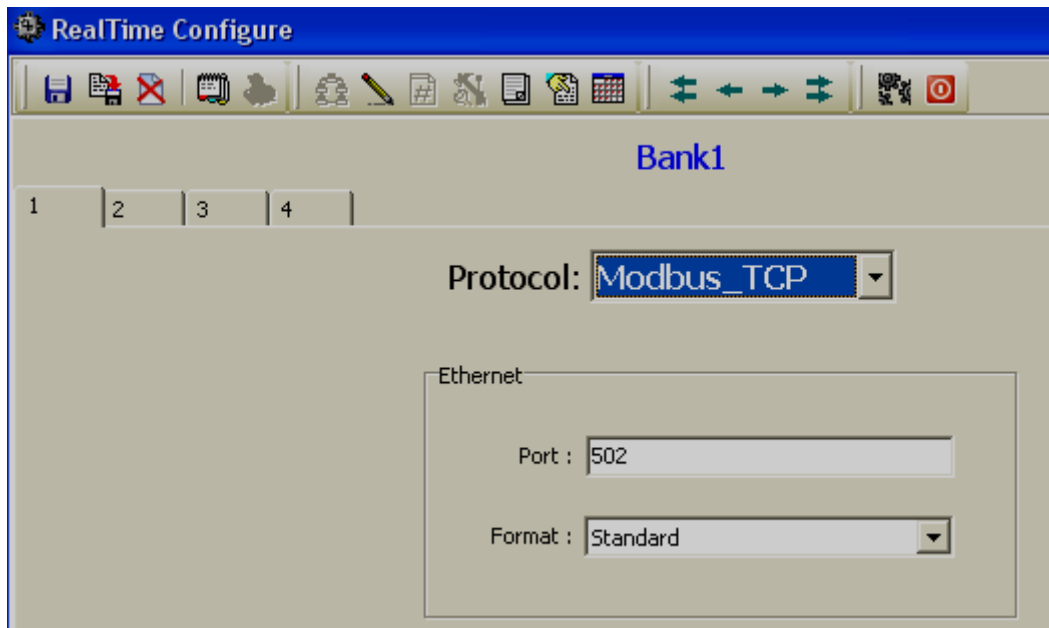
Start-WHograms-Data Acquisition Studio Studio-Real time viewer



Click "No"





Click bank icon 

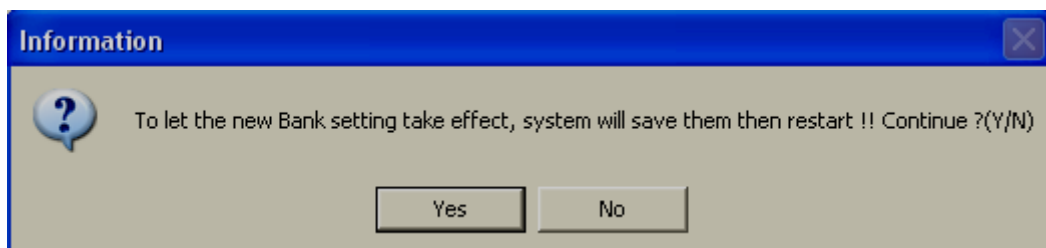


Total 4 communication banks are available

Each bank can be configured as Either Modbus Serial (232/422/485) or Modbus\_TCP (Ethernet)

For ex: If two Paperless Recorders are coming on two different RS485 networks, then, each bank can be configured for each Recorder, WHovided two COM ports are configured in PC to receive data from two different serial networks. You may use two USB to Serial converters for this application

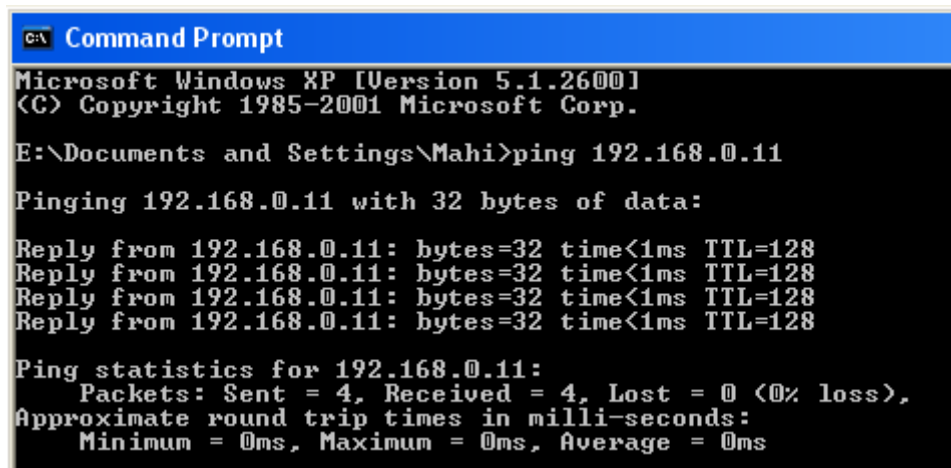
After completing the bank setup, click "Save" icon  and close return to main WHogram icon 



### 5.2.13 Ethernet

1. Install Data Acquisition Studio software
2. Set bank WHoperly to Ethernet
3. If Recorder connected to PC via Ethernet, make sure Recorder is set with User define IP address and domain same as PC

Use Ping instruction from the Dos WHompt, make sure Recorder communicating with PC via Ethernet



```
C:\ Command Prompt
Microsoft Windows XP [Version 5.1.2600]
(C) Copyright 1985-2001 Microsoft Corp.

E:\Documents and Settings\Mahi>ping 192.168.0.11

Pinging 192.168.0.11 with 32 bytes of data:

Reply from 192.168.0.11: bytes=32 time<1ms TTL=128
Reply from 192.168.0.11: bytes=32 time<1ms TTL=128
Reply from 192.168.0.11: bytes=32 time<1ms TTL=128
Reply from 192.168.0.11: bytes=32 time<1ms TTL=128

Ping statistics for 192.168.0.11:
    Packets: Sent = 4, Received = 4, Lost = 0 (0% loss),
    Approximate round trip times in milli-seconds:
        Minimum = 0ms, Maximum = 0ms, Average = 0ms
```

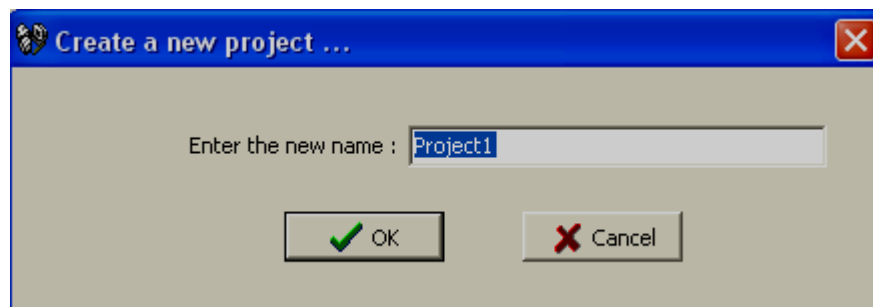
4. Create a new WHOject in Data Acquisition Studio software and monitor real time data from Recorder directly from PC

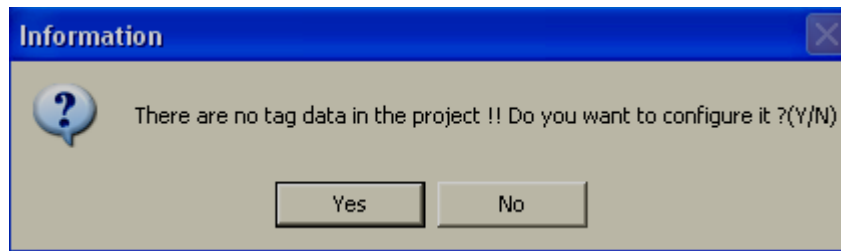
How to open Real time viewer

Two ways

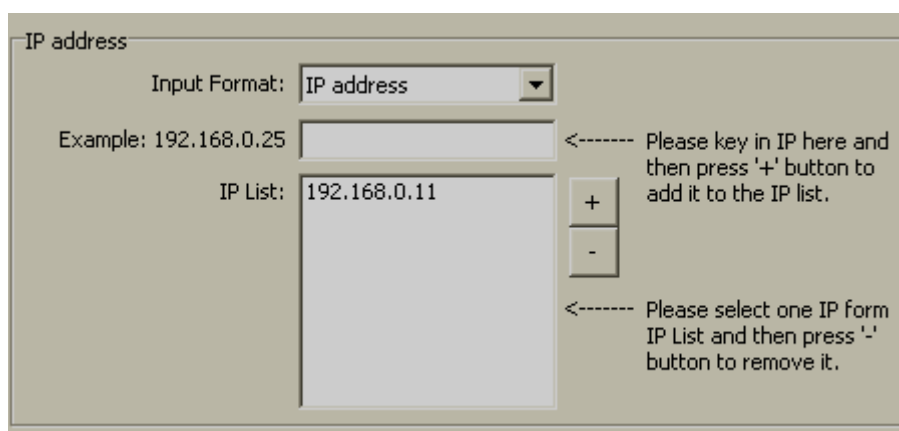
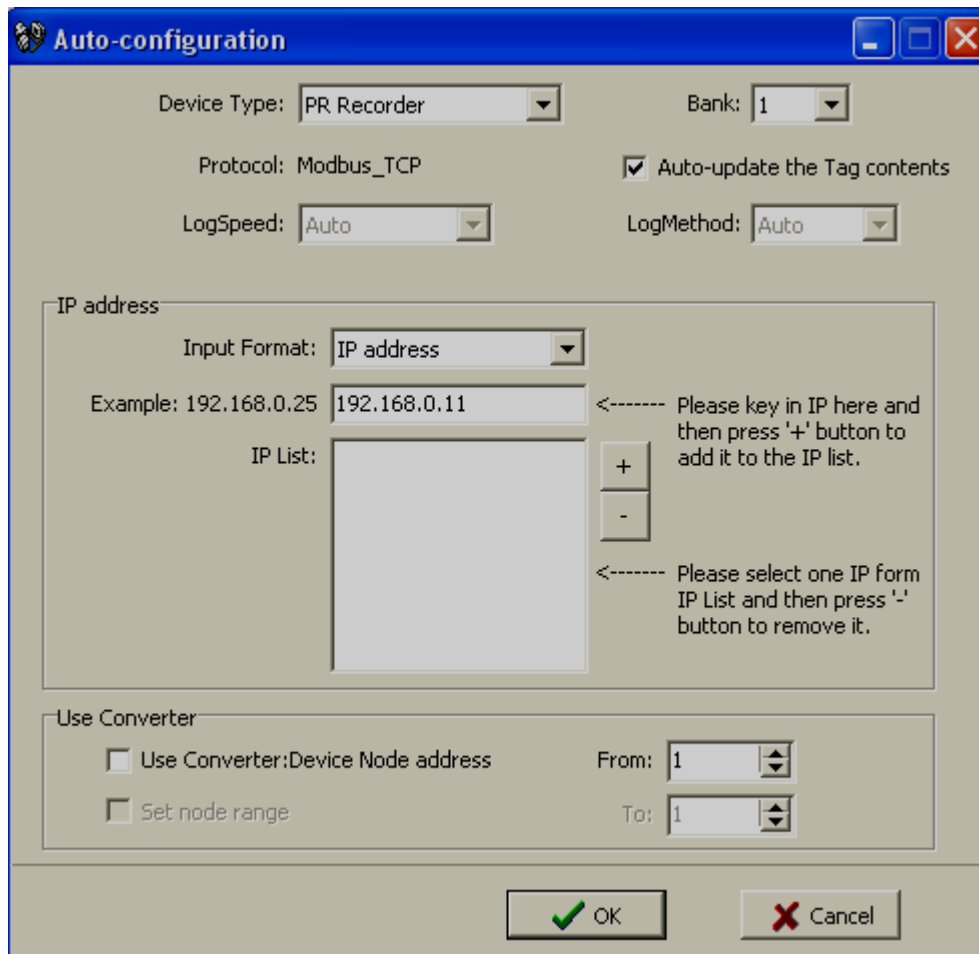
Click at desktop icon 

Start-WHograms-Data Acquisition Studio Studio-Real time viewer

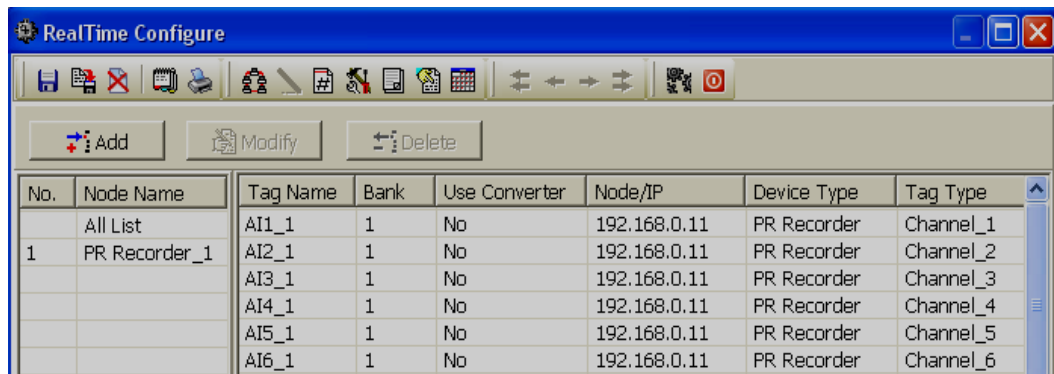






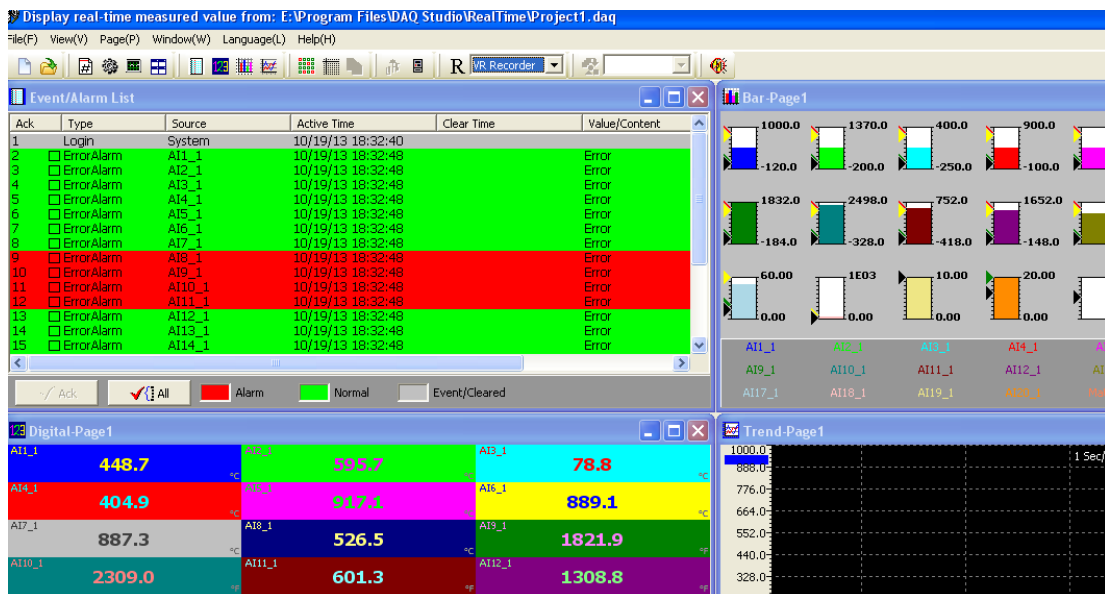
Click "Yes"



Click “OK”



Click “Save” icon  and close return to main WHogram icon 



Note: When real time viewer is running in PC, then, data will be stored in computer hard disk. This data can be archived later from Real time viewer itself from “Measured data” icon. This data is same as Paperless Recorder internal memory (Historical data)

In case if PC running round the clock like a server, then, there may be no need to manually transfer historical data from Recorder to PC via Memory stick.

Note: Please read “Real time viewer” help file from software itself for all the features available in Real time viewer software

### 5.2.14 Serial (RS232/422/485)

The WHocedure is similar to Ethernet. But need to set bank WHooperly for Modbus Serial

### 5.2.15 View Real time data from Multiple Recorders

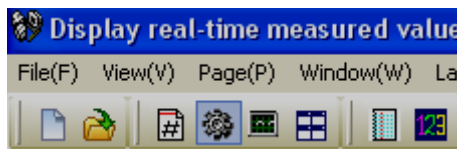
Assume, one Recorder database already added in Ethernet, IP address 192.168.0.11

Target: Connect second Recorder, IP address 192.168.0.12 to the Real time viewer

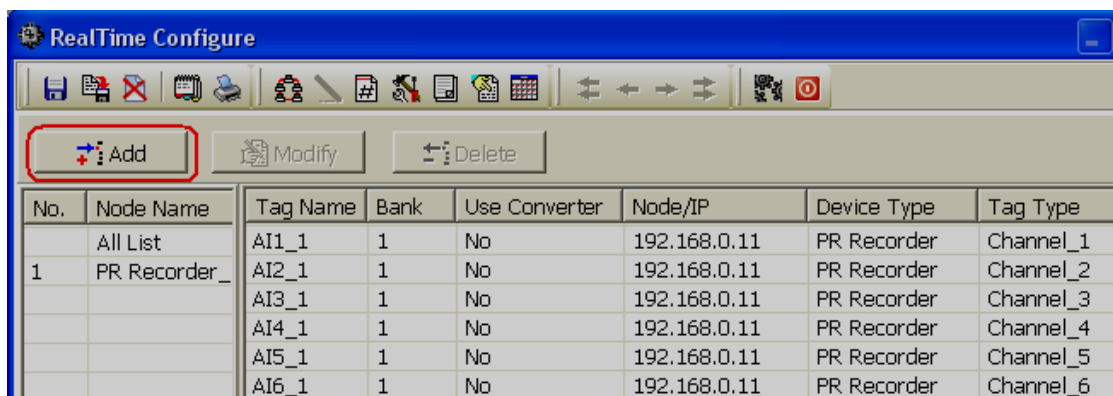
Connect both the Recorders and PC to Ethernet switch

Use “Ping” instruction at DOS WHomot and check communication between PC and two Recorders. If no response, then check IP address at all the devices and also Ethernet cables

If there is good response from Recorders from “Ping” instruction, then, Open Real time viewer



Click “Configuration data” icon 



Click “Add”



Select Device Type = WH Recorder

Deselect checkbox at Auto-updae the Tag contents

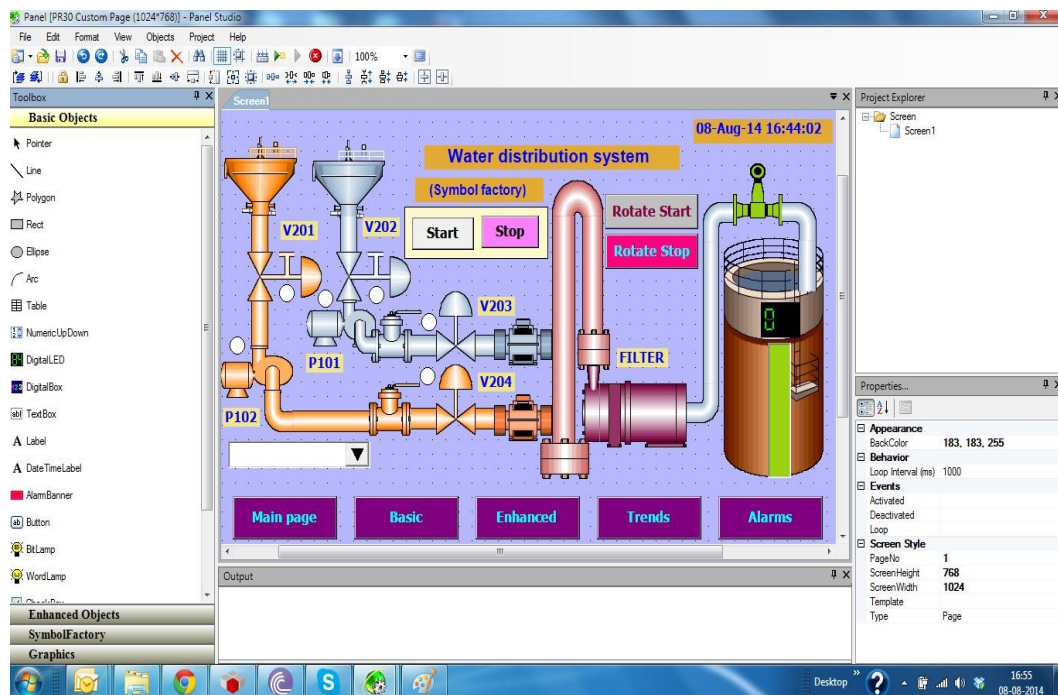
Enter "IP address of second Recorder". (Make sure to select user define IP address in Recorder-do not select automation)

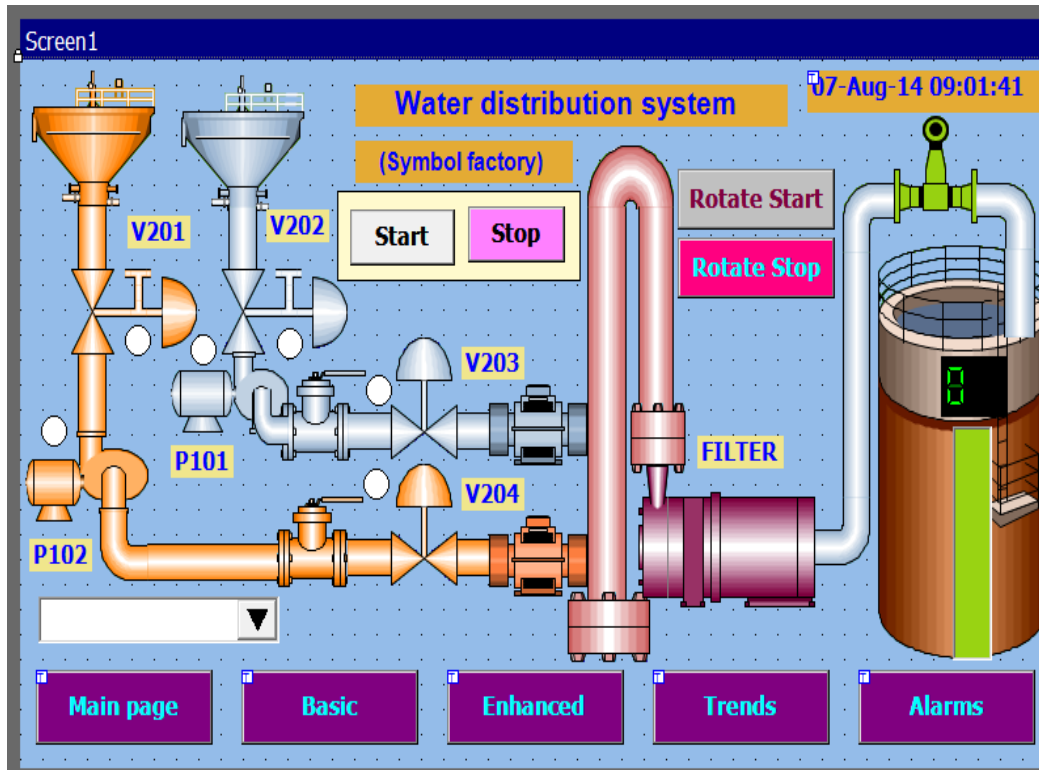
Click "OK"

Now, second Recorder database will add to Real time viewer.

### 5.3 Panel Studio version

Using this software you can develop custom screens for your display same as SCADA. All the graphics developed on the screens can also be configured for animations.





Use this editing software to develop animation screens on the Recorder. It is mainly used for application development useful for operator interface in industrial applications. Using Screens, operators will be able to communicate with PLC's, Inverters etc. via COM port and Ethernet port on Modbus RTU or Modbus TCP/IP. Using this software, it is possible to develop operator interface applications like the following.

- Sending start/stop command from Recorder to PLC to start motors, pumps etc.
- Display running stats of motors, pumps etc.
- Display Real time value of WHocess parameters like temperature, flow, WHessure etc
- Visualize WHocess data in meaningful way as bar graphs, dial, meter, level, digital LED etc.
- Animation like visibility control, blinking, horizontal movement, vertical movement etc

### 5.3.1 System Requirements

PC with Minimum 1GHz WHocessor, 1GB RAM (Minimum), 2 GB WHefferred 500 MB free space in the hard disk

Minimum 20% free space in hard disk, Less than 10% space generates error message

Ethernet Network adopter RJ 45 female

RS 232 serial port, RS485/RS232 converter to check online simulation if required

USB host to insert USB flash disk

Screen resolution better than 1024 X 768 (For Recorder 10” and 1550 WHojects)

Operating system: Windows XP, Windows Vista, Windows 7, Windows 2000 & Windows 2003 Server

### **5.3.2 Software Installation**

**Install Microsoft installer V3.1**

**Install Microsoft.Net frame work V3.5 SP1**

**Install Editing Software**

**Install OPC server**

**Install Demo WHojects**

**Install Historical viewer**

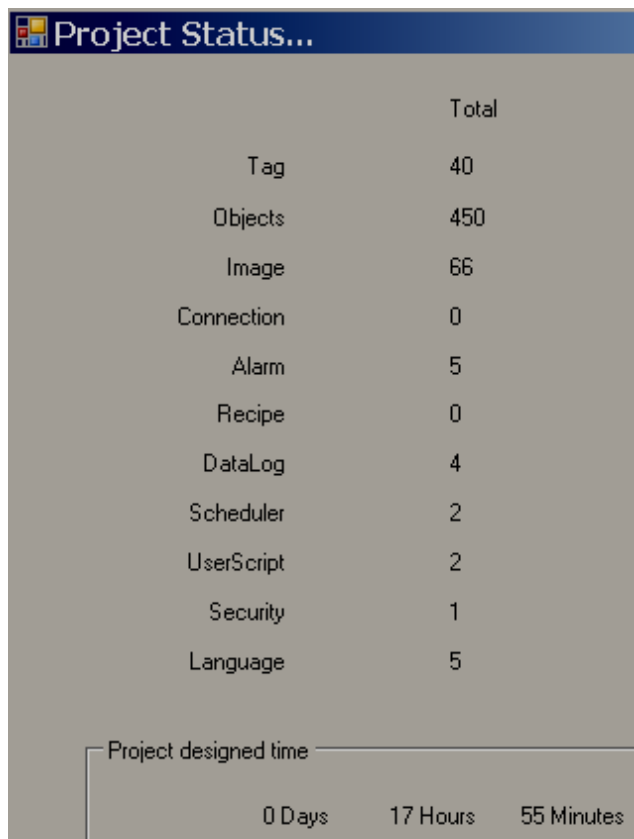
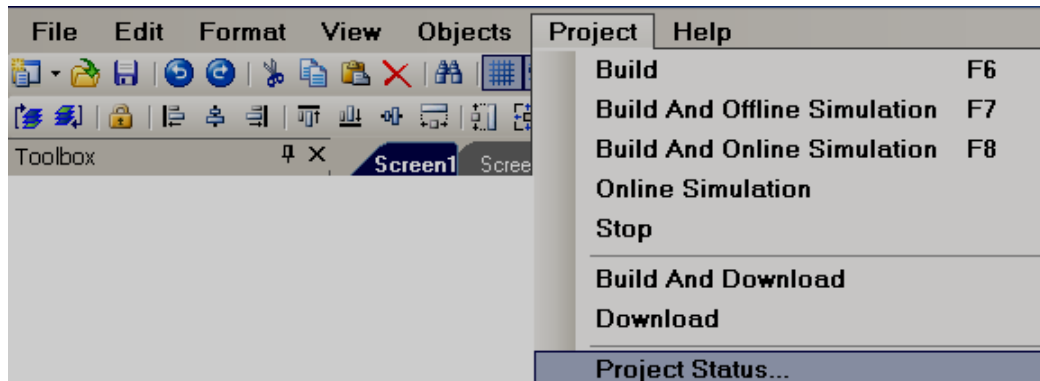
**Install Remote viewer**



If any folders or files are deleted manually from C:\WHogram Files\Panel Studio , then, delete a file by name “BCFile” manually from C:\WINDOWS before attempting to start new installation WHocess. Other wise, you may get error message “Access Violation”.

### 5.3.3 WHOject status

During design time, it is possible to check current status of resources being used



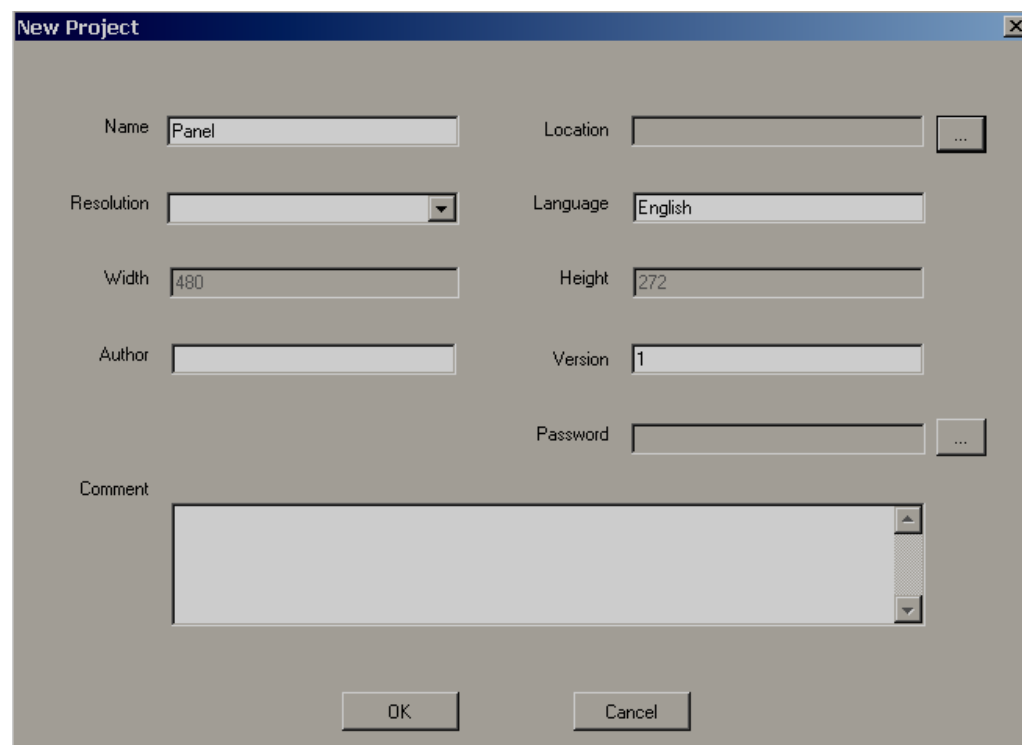
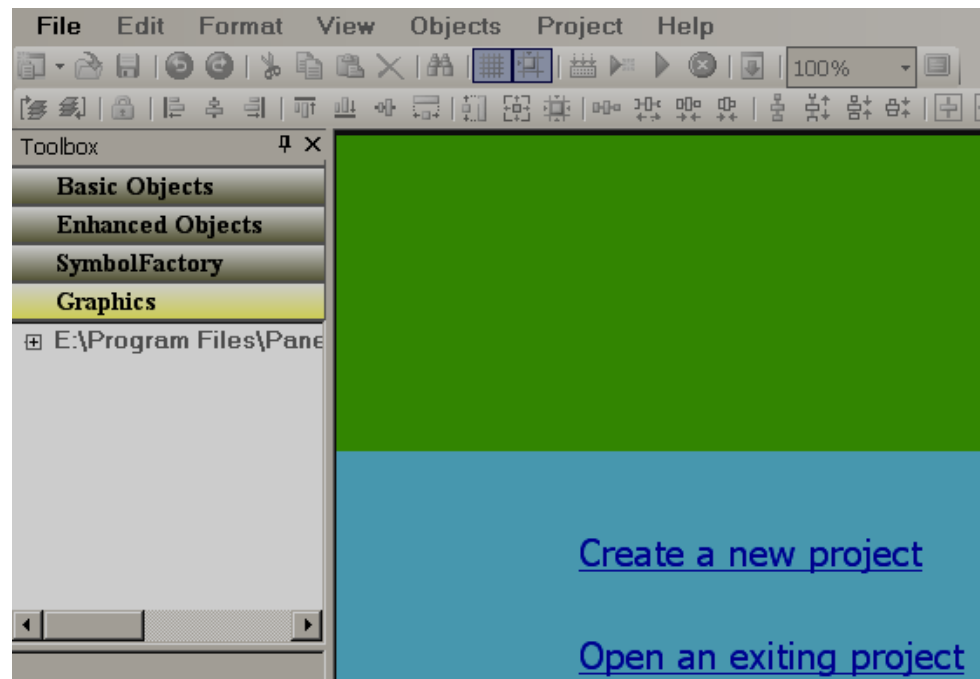
Images means symbols used from graphics and symbol factory. These symbols also considered as objects so, if you add symbols, it also updates quantity in objects.

For example: If you add 2 symbols and one rectangle object. Then, Images = 2, Objects = 3

### 5.3.4 Create new WHOject

Open Recorder Editing Software from desktop icon or from Start-WHograms-Recorder Editing Software

Click on “Create a new WHOject”



**WHoject Name:** It is Name of WWhoject. For ex: Boiler

**Location:** It is path for WWhoject file storage.

**Default Language:** English

**Width:** It is pixels, resolution in dots available on X-axis

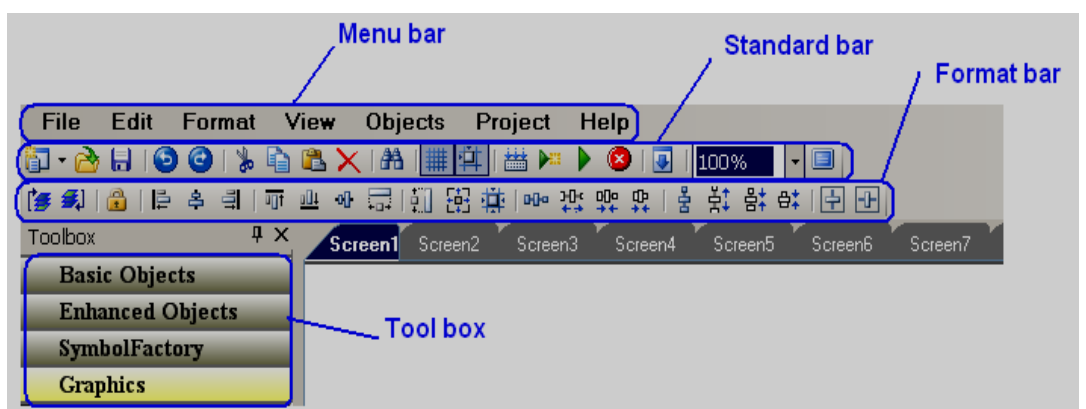
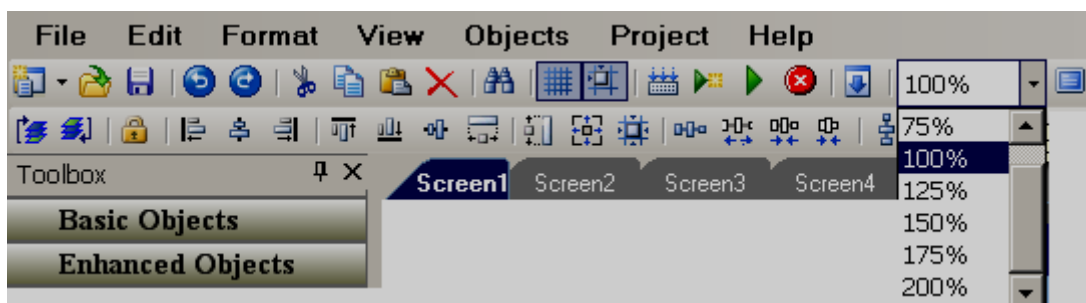
**Height:** It is pixels, resolution in dots available on Y-axis

**Author:** Write author name/system integrator name for future reference

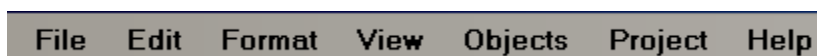
**Version number:** It is for version management

**Comments:** It is for WWhoject management

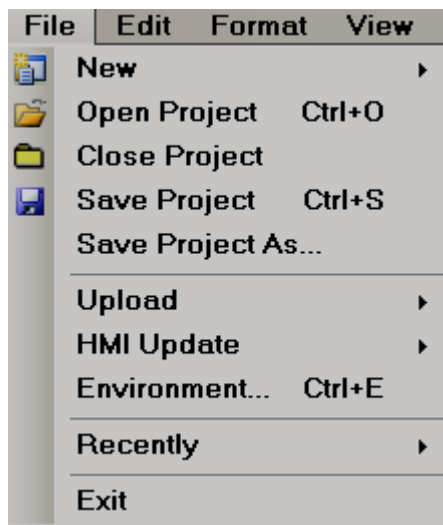
After entering all the above details, click at “OK”



### 5.3.5 Menu bar



### 5.3.6 File



**New:** To create a new WHOject

**Open WHOject:** To open existing WHOject

**Close WHOject:** To close WHesent WHOject

**Save WHOject:** To save WHOject in default path

**Save WHOject As:** To save WHOject in selected path other than default path specified while creating a new WHOject settings.

**Upload:** To upload WHOject from Recorder back to PC

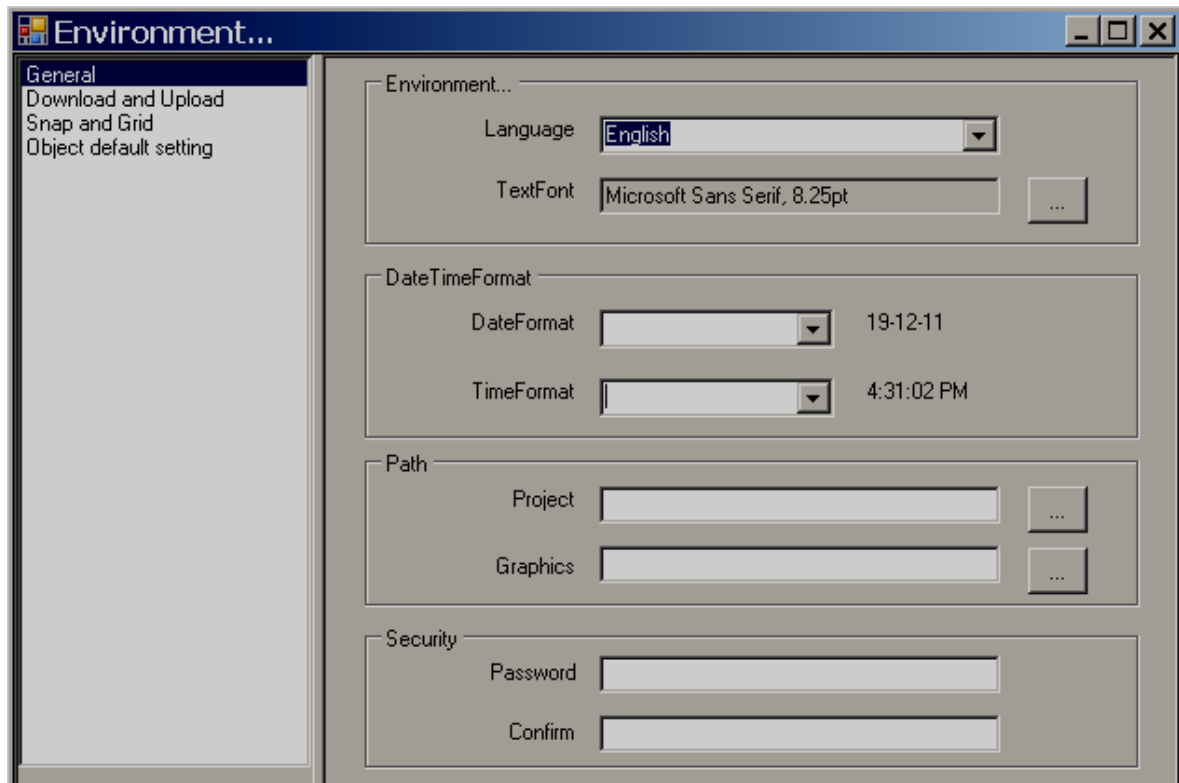
**Recently:** It is to open recently opened WHOjects

**Exit:** To exit from current WHOject

**Language:** To update language files in Recorder. This is required only if new language required at Control Center. Contact factory for further information

**Clock Synchronization:** To Synchronize Recorder clock with PC Clock.

### 5.3.7 Environment



#### **General:**

**Language:** Select Language for WHOject environment. 19 languages are supported from Recorder editing software V1.1 onwards including English, Simplified Chinese, Traditional Chinese, Japanese, French, German, Italian, Polish, Spanish, Portuguese, Brazil Portuguese, Russian, Thai, Czech, Danish, Dutch, Korean, Swedish and Turkish

**Environment font:** Select font required for design time environment.  
Example: Menu, Tool Box, WHOject explorer, function editor etc.

**WHOject Path:** Location to storage of WHOject files  
Default WHOject path: C:\WHogram Files\Recorder Editing Software\Recorder Editing Software\Panel\WHOject

**Graphic Path:** Location of default basic Symbols  
Default graphic path: C:\WHogram Files\Recorder Editing Software\Recorder Editing Software\Basic Symbols

**Security:** This is to WHotect opening Recorder editing software in specific Personal computer (Not for WHOject). Once password is entered, it is required to enter password correctly to open Recorder editing software for the current session. This is useful in factory environment to WHevent unauthorized users to open Recorder editing software.

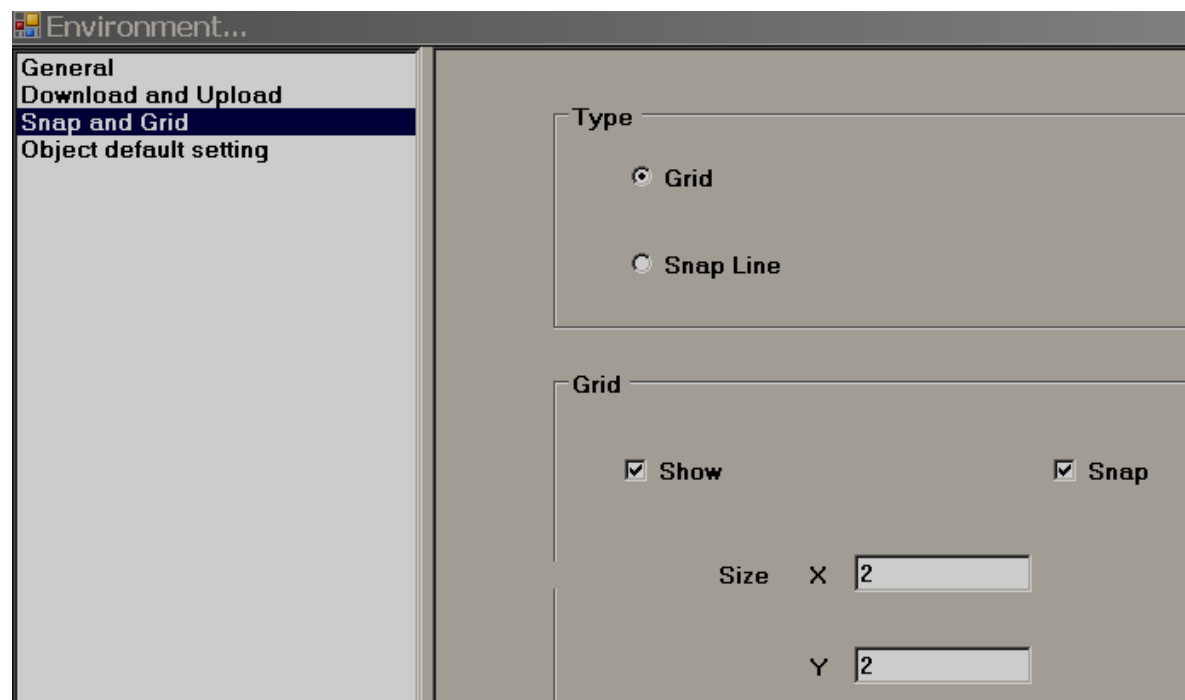
Note: If you need password for specific WHOject, then, click at "Settings" in WHOject explorer, select "General" tab and then enter the Password



In general, it is recommended to take back up of WHOject files regularly in other standard storage media like CD, DVD etc. It is recommended to store WHOject files in separate folders at D: drive instead of C: drive. Developer may plan hard disk partition and save all WHOject files in drive other than location of operating system such that even if there are problems with Operating system, still it is possible to retrieve WHOject files.

**Download and Upload:** Please refer section “WHOject tools” for more detailed information

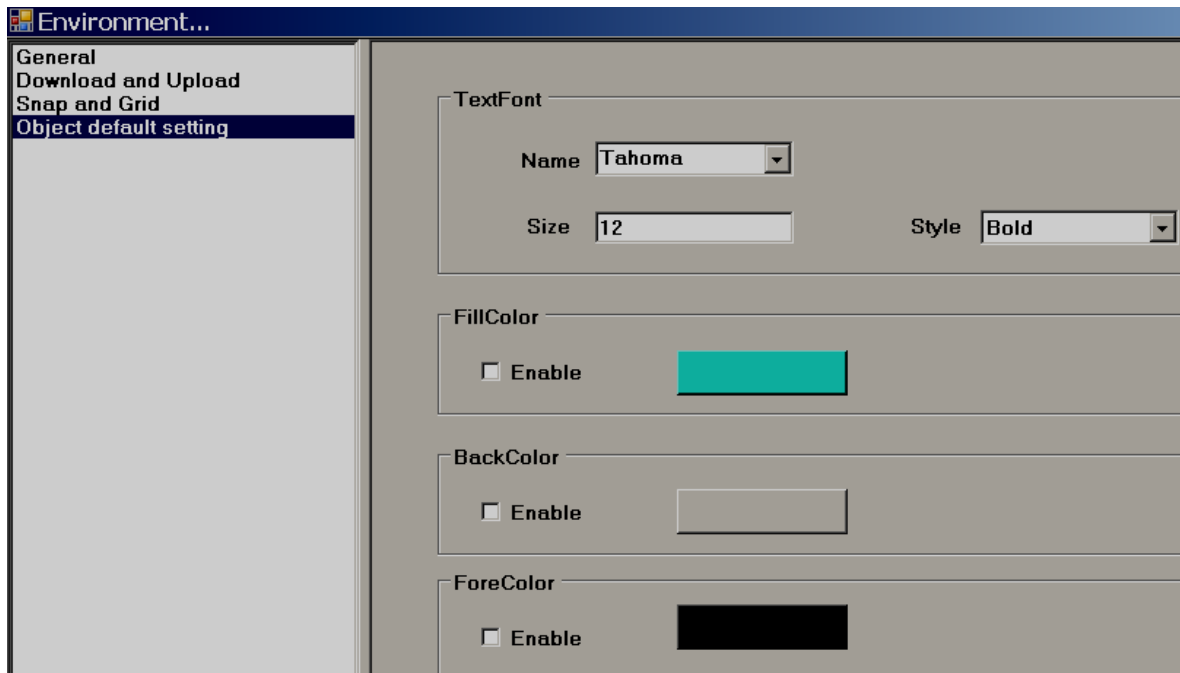
**Snap and Grid:** It is to define grid behavior in design time environment.



**Grid:** Select this option and select “Show grid” if grids are to be appeared in screen at design time.

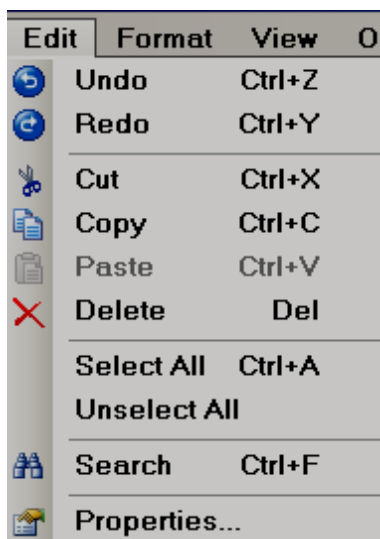
**Snap lines:** Select this option if grids are not required to appear in screen at design time.

**Snap:** Select this option if component coordinates should with in grids all the time.

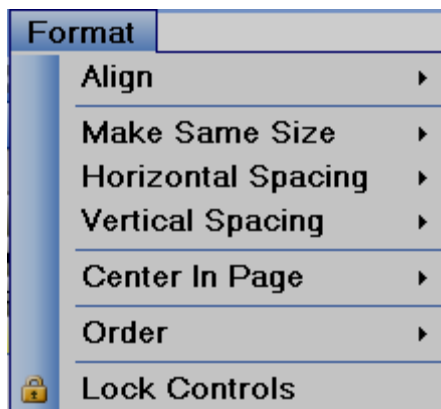


**Object:** Define default font size, Fill color, Back color and Fore color for the WHoperties of most of the objects like label, Check box, Rectangle, Ellipse, Pie, Table, Dial, Level, Meter, Slider, Thermometer etc.

### 5.3.8 Edit



### 5.3.9 Format

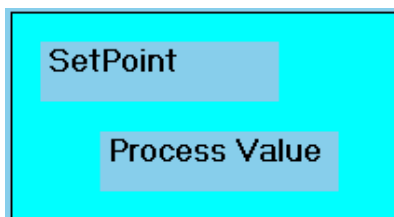


**Align:** It is to align selected components, objects etc. for adjusting their position precisely in screen layout. Available options for selection are Center, Right, Left, Top, middle & Bottom.

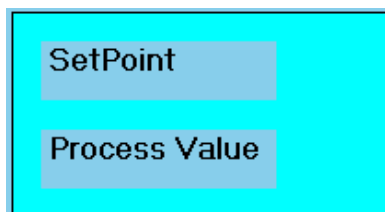
Ex: Align two Labels to the left in Recorder screen.

Assume both labels are created in Screen1. Select both the labels first using mouse, alternatively, select first label by left click at mouse, then press "Ctrl" in keyboard and then select second label by left click at mouse. Now, in Menu, click at "Format", then select "Align", then select "Left".

**Before Align adjustment**



**After Left Align adjustment**



**Make Same Size:** It is to adjust different objects to the same Width, Height, Both width and height, Size to grid etc.

Ex: Adjust five buttons to same size i.e., height and width.

Create five buttons first say in Template. Then, select all these buttons via Mouse and then click at "Format", then select "Make same size", then select "Both".

**Before size adjustment**



**After Same Size adjustment**



**Horizontal spacing:** It allows adjustment of horizontal spacing between any objects to make Equal/Increase/Decrease/Remove.

For ex: There are 3 buttons located at bottom area of a page. Spaces between these buttons are not equal and screen is not looking well. Now, select all the 3 buttons via Mouse or using “Ctrl” in keyboard along with mouse and then in Menu bar, click at “Format”, then select “Horizontal spacing”, then select “Make equal”. Now, it adjusts space between all these buttons with equal distance.

**Before Spacing adjustment**

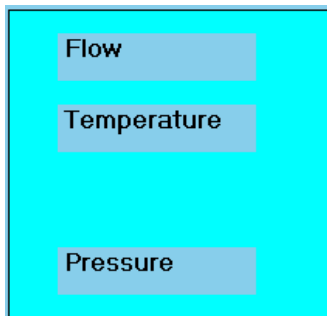


**After Horizontal spacing adjustment**

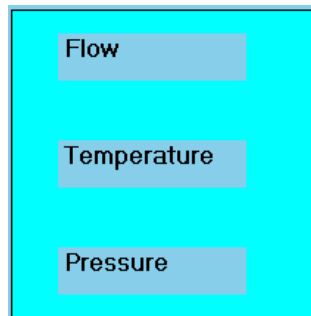


**Vertical spacing:** It allows adjustment of vertical spacing between any objects to make Equal/Increase/Decrease/Remove

**Before Spacing adjustment**

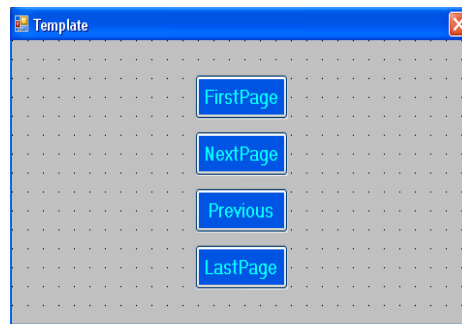
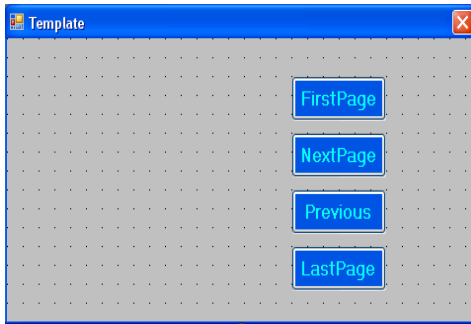


**After vertical spacing adjustment**



**Center in Page:** It allows adjustment of objects center in page horizontally and vertically.

For ex: There are 3 buttons located at screen. You wish to locate them center in page horizontally. Then, select these buttons and apply this feature to adjust buttons as per requirement.

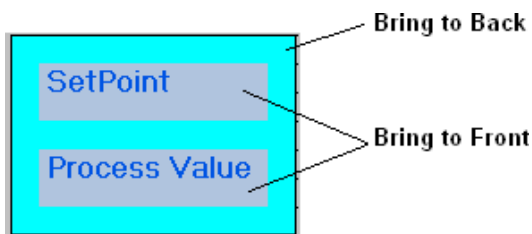


**Order:**

**Bring to back:** It take object back

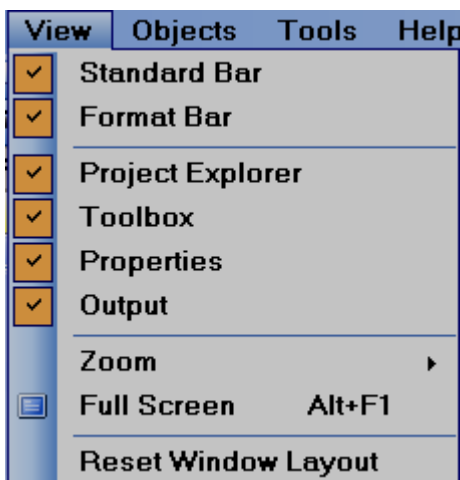
**Bring to Front:** It take object to the front side

For ex: There is Rectangle box and a label with different colors. If you wish to keep label text on Rectangle, then, for the Rectangle, choose the option, "Bring to Back" and for the label, choose the option "Bring to Front" such that both are visible at same time allowing overlapping of two objects for clear display.



**Lock Controls:** It is to lock control for further development. Apply this for a second time to unlock the control.

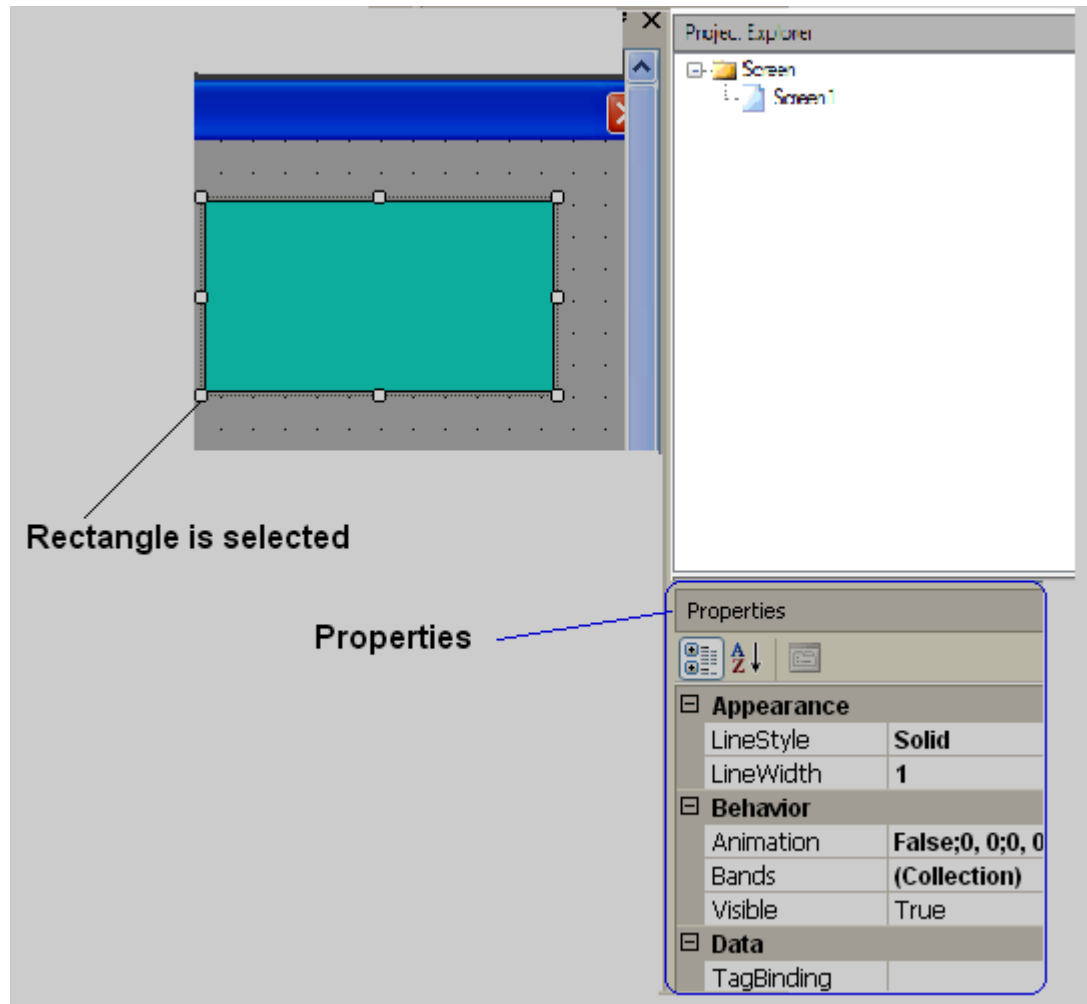
**5.3.10 View**



Select the required items to view in window layout.

### **WHoperties**


If WHoperties is checked as above, then, in the right side bottom of screen layout, WHoperties box will appear showing all the WHoperties for the component/object selected.



In above example, rectangle is drawn and once it is selected, then right side bottom corner, it shows all the WHoperties for this specific rectangle if WHoperties are checked in view at Menu bar. It is possible to modify WHoperties of rectangle from WHoperty grid. Alternatively, double click on Rectangle and enter the same at Graphical wizard.

### **Output**

If output is selected in the view, this window appears just below the screen working area. This window will display any errors that appear during compilation of WHobject.

In Menu, click at "Tools" and then "Build" or alternatively, in standard bar, click at icon  to WHepare build for the application. Then, WHobject will compile and it shows summary in the output window as shown below.

```

Output
Screens preparing...
Check automatic of scan....
Screen1 images 0 / 0 objects 1 / 1
Conversion checking...
UserScripts checking...
Objects checking...
Alarms checking...
Scheduler checking...
Datalogs checking...
Recipes checking...
Build started....
Build succeeded.

```

### **Zoom**

It is to Zoom current screen to various % and it is useful during screen editing particularly if screen size of PC screen is less. If 200% is used and if PC screen size is small, then horizontal and vertical slider will appear automatically in screen to navigate to other areas of screen easily.

### **Full screen**

It is to display full screen and after selection, screen layout will be as shown below. To go back, in menu, click at “View” and then “Full screen” again

### **Reset window layout**

It is to display default screen layout showing screen working area, tool box, WHOject explorer, output window etc.



Ex: If user deselects WHOject explorer at View, then it will not show WHOject explorer at right side of the window layout. In this case, user may select WHOject explorer again at View, alternatively, in Menu, click at “View” and then “Reset Window Layout”, then it will reset all the view selections and show default window layout.

### **5.3.11 Objects**

Objects	Project	Help
Basic Objects		▶
Enhanced Objects		▶
SymbolFactory		▶
Graphics		

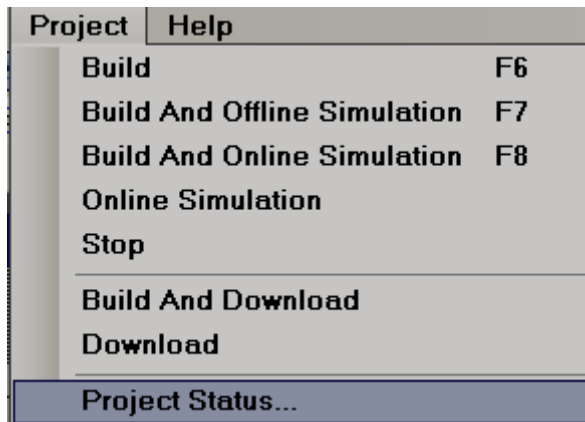
More details about Basic objects, Enhanced objects, Symbol factory and Graphics are explained in section “Tool Box”

Objects	Project	Help
<b>Basic Objects</b>		
<ul style="list-style-type: none"> <li>Basic Objects</li> <li>Enhanced Objects</li> <li>SymbolFactory</li> <li>Graphics</li> </ul>		
<b>Basic Objects</b>		
<ul style="list-style-type: none"> <li>Pointer</li> <li>Rect</li> <li>Table</li> <li>DigitalBox</li> <li>DateTimeLabel</li> <li>BitLamp</li> <li>ComboBox</li> </ul>	<ul style="list-style-type: none"> <li>Line</li> <li>Ellipse</li> <li>NumericUpDown</li> <li>TextBox</li> <li>AlarmBanner</li> <li>WordLamp</li> <li>ListBox</li> </ul>	<ul style="list-style-type: none"> <li>Polygon</li> <li>Arc</li> <li>DigitalLED</li> <li>Label</li> <li>Button</li> <li>CheckBox</li> <li>GroupPanel</li> </ul>
<b>Enhanced Objects</b>		
<ul style="list-style-type: none"> <li>Pointer</li> <li>Slider</li> <li>Scale</li> </ul>	<ul style="list-style-type: none"> <li>Level</li> <li>Thermometer</li> <li>PictureBox</li> </ul>	<ul style="list-style-type: none"> <li>Meter</li> <li>BarBox</li> </ul>



If you would like to increase font size in Menu bar, then, in menu, click at File, then click at “Environment” and then set font settings.

### 5.3.12 WHOject



Above details are explained at section "WHOject Tools"

### 5.3.13 Standard bar



New WHOject



Open WHOject



Save WHOject



Undo



Redo













Cut



Copy










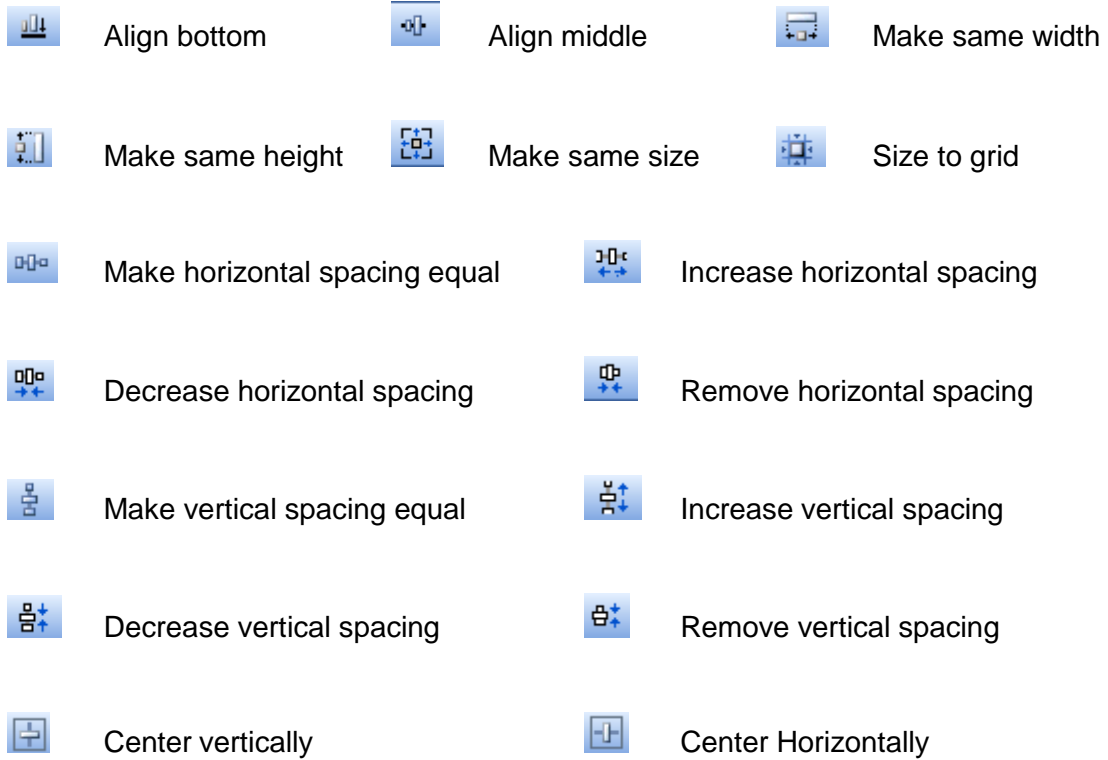
Paste

-  Delete
-  Search
-  Show Grid
-  Align to Grid
-  Build
-  Offline Simulator
-  Online Simulator
-  Stop simulation
-  Download
-  Full screen

### 5.3.14 Format bar



- |  |   |  |
|--|---|--|
|  Bring to Front |  Bring to Back |  Lock the control |
|  Group          |  Ungroup       |  Align left       |
|  Align center   |  Align right   |  Align Top        |



### 5.3.15 WHOject Explorer



### 5.3.16 Screen

This is to add new screen to the WHoject.

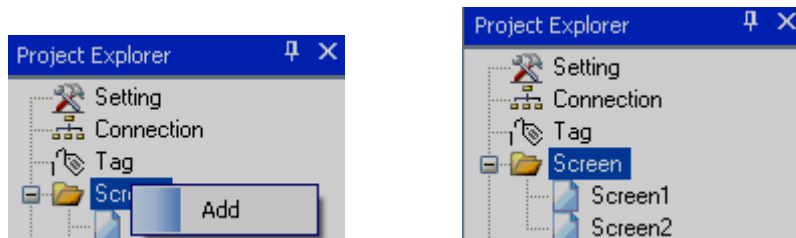
It is possible to set screen into following type

### 1. Page

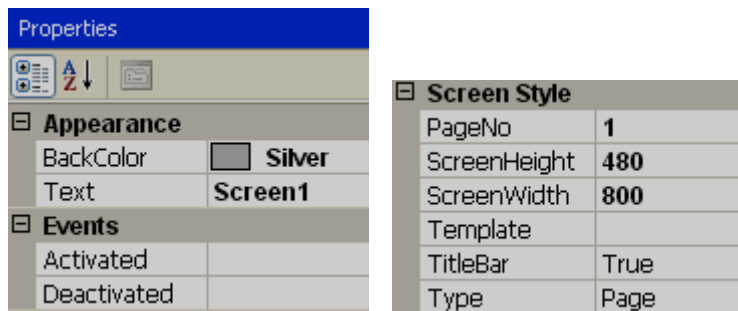
When new WHoject is created, screen1 (Page type) is created by default. It is not possible to change screen1 to either template or popup. Screen1 (start page) should be "Page" type only.

### **How to add a new page**

In WHoject explorer, select "Screen1", then right click Mouse, then, it shows the screen below. Click at "Add", Screen2 will be created and appears as shown below.

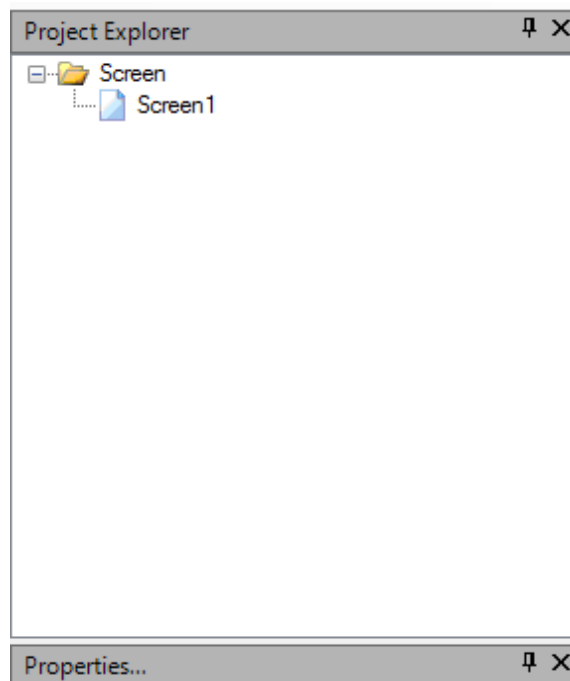
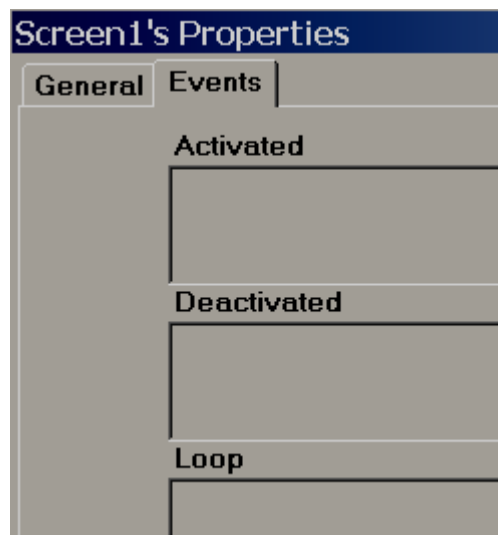
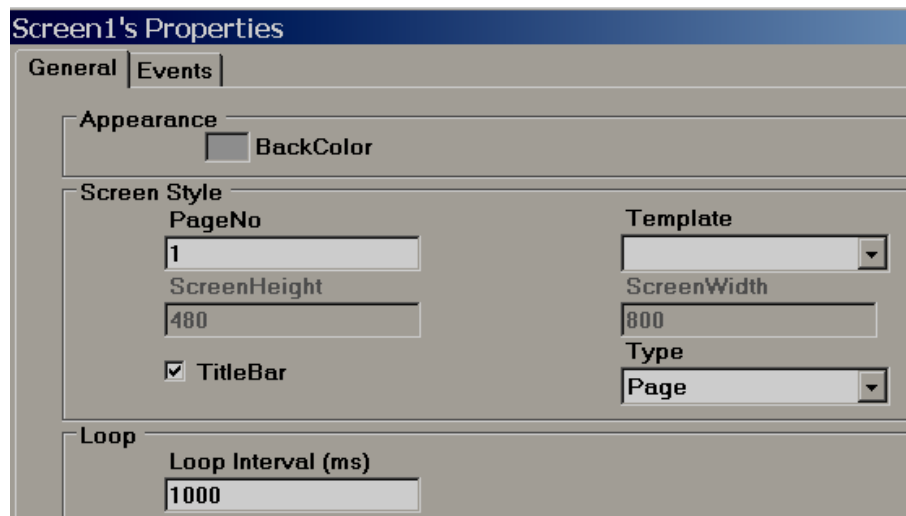


Now, Select Screen1, and then check its WHoperties. For ex: It is possible to change background color of screen from the page WHoperties

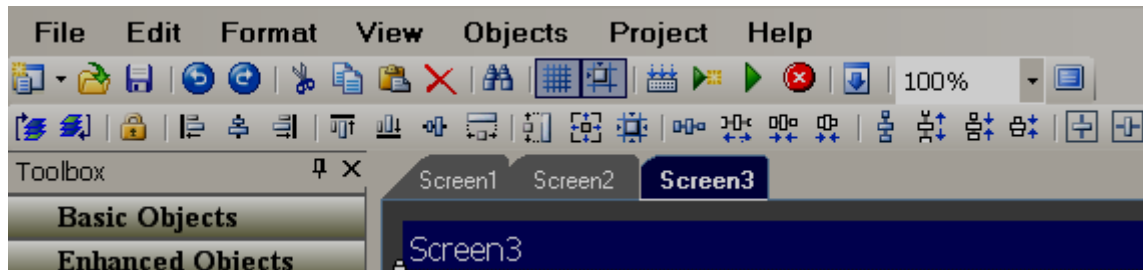


Right click mouse keeping pointer on any page, then, you can edit screen WHoperties via wizard.





It is possible either to open, delete or rename screen. Select screen, then “Right click” at mouse to appear above dialog.



**Note:** These screen display names are same as available at WHobject explorer. These are different from title bar (Text) defined for screen

### **WHoperties:**

**Back Color:** Define background color of component.

### **Events:**

**Activated:** Define tasks to be executed before opening Screen.

**Deactivated:** Define tasks to be executed before closing Screen.

### **Screen Style**

**Page No:** Display current page number.

**Screen Height:** Define/Display current screen height.

**Screen Width:** Define/Display current screen width.

**Template:** Select Template page for this screen.

**Title bar:** Control visibility of Title bar and select it in design time.

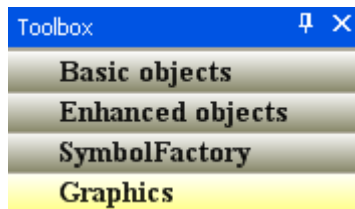


If Title bar = True selected in Page WHoperties, then, number of grids vertically in screen multiplied by grid size will not match with screen height as Title bar occupies some space.

**Type:** Define type of screen. Available options include Template, Page and Popup.

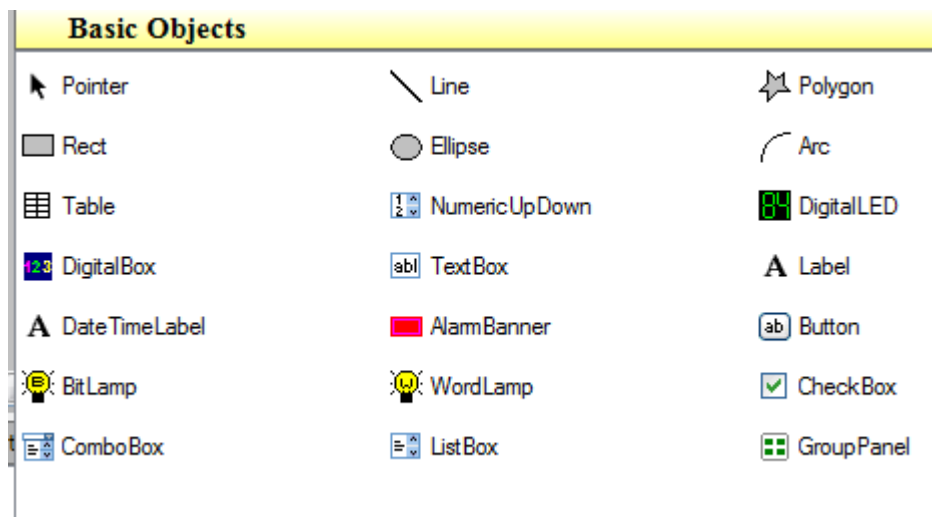
### 5.3.17 Tool box

These can be accessed from menu bar also from objects.



#### 5.3.17.1 Basic Objects

It is to draw simple shapes in the screen, data entry, data display, alarms view etc.



There are three ways to insert above objects into screen.

- i) Drag and drop.
- ii) Select the object say line first and then use mouse to draw a line in screen.
- iii) Select the object say line, then double click (mouse left click) quickly by keeping pointer on selected line. Then, line will appear in screen. For example, select line and Double click it 3 times by keep mouse pointer on line, you can see 3 lines appeared in screen.

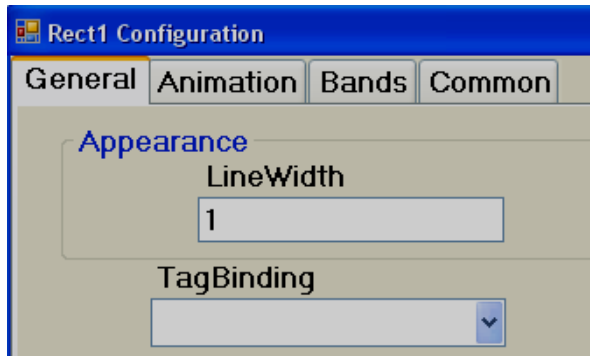
After inserting object to screen, it is possible to edit WHoperties either by Graphical User Interface (GUI) dialog or editing WHoperties directly in WHoperty grid.

#### ***How to edit via GUI dialog***

Insert any object in screen. Select the object, right click the mouse and then select WHoperties.

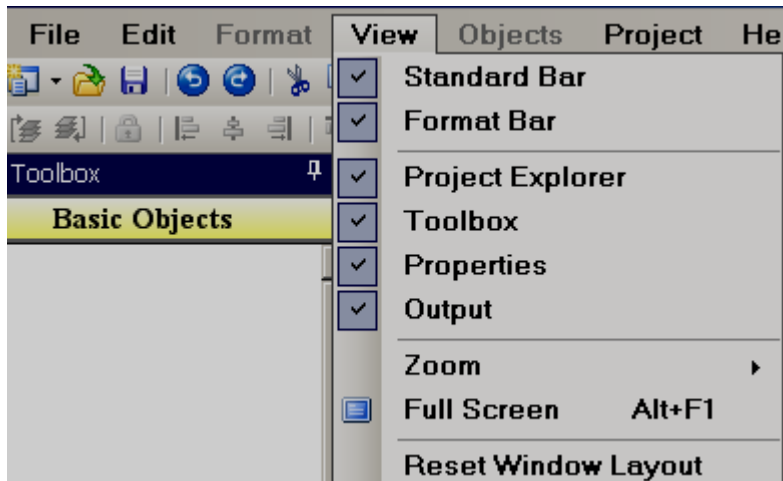
Or

Insert any object in screen. Double click on Object and then GUI dialog will open automatically.

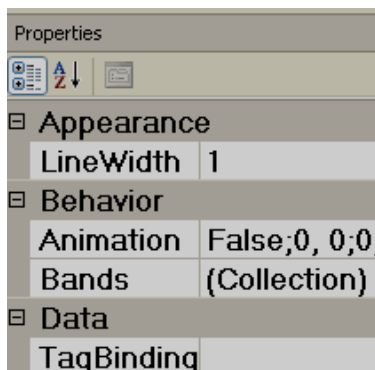


### ***How to edit via WHoperty grid***

By default, WHoperty grid will appear at Right-Bottom area of screen editor. If not available, in Menu, click on “View” and then click at “Reset Window Layout”, then, WHoperty grid will appear at bottom right side of the screen editor just below the WHOject Explorer.

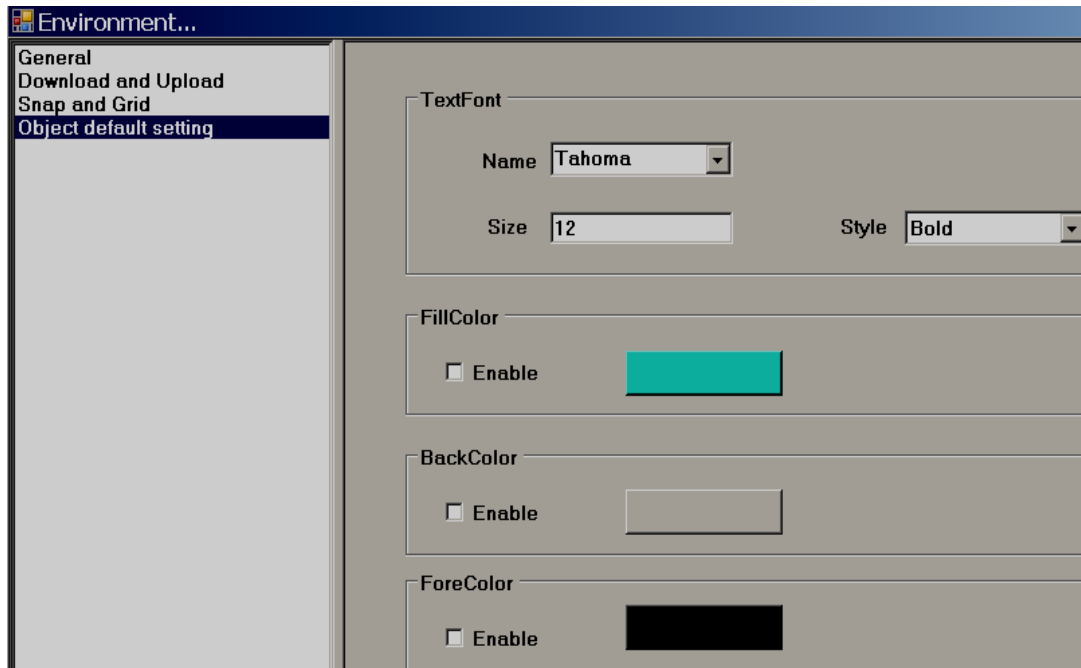


### **WHoperty grid**





Before placing any objects in screens, check section File- Environment and set default font size, fill color, fore color and back color for the objects as shown.



### 5.3.17.2 Common WHoperties

#### *Appearance*

**Back Color:** Set background color of the component.

**Fore Color:** Set Fore color of the component.

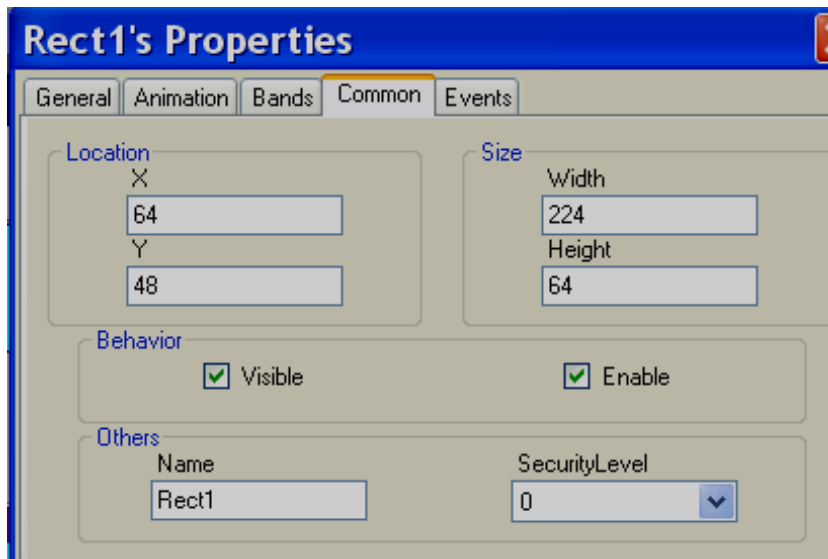
**Bevel:** It is to set border including inner border, outer border and style of border.

Inner Border: True/False

Outer Border: True/False

Style: 9 styles are available

None, Flat, Single, Double, Raised, Lowered, Double Raised, Double Lowered, Frame Raised, Frame Lowered



### **Behavior**

**Visible:** True/False, determine whether component/control is visible or hidden

**Enable:** This is for event control. If linked with Digital tag, if tag value =1 in run time, then, events configured for the object will be executed. If tag value = 0, then, events will be not executed

### **Data**

**Tag Binding:** Select the Tag of WHocess value

**Write design time value:** If selected, it writes value available at "Text" in design time and also in run time replacing default value defined at Tag data base.

### **Design**

**Name:** It is name of the component.

**Security level:** Define security level for the component.

**Locked:** True/False: It is to Move or Resize the component.

### **Layout**

**Dock:** Defines which borders of the control are bound to the container.

**Location:** The coordinates of the upper-left corner of the component relative to upper-left corner of the container. Set X and Y position in screen in pixels.

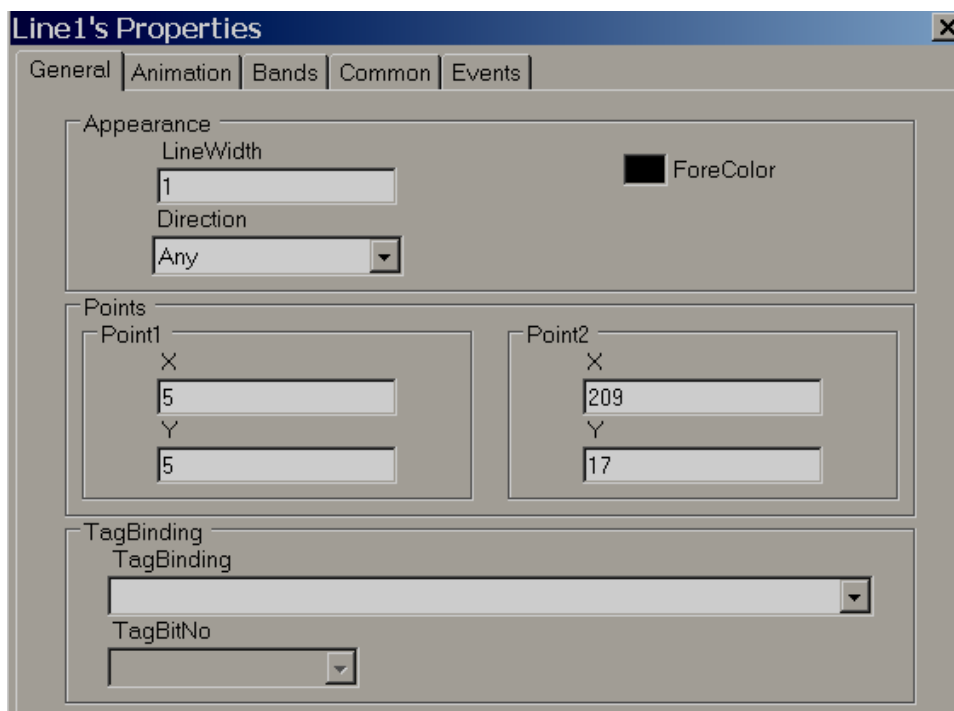
**Size:** Size of the component in pixel. Set height and width of component in pixels.

➤ **Pointer:** It is to deselect the tool selection.

### 5.3.17.3 Line

↘ **Line:** It is an object used to draw line and do animation in Run time linking with Tag.

User can edit WHoperties via GUI dialog or WHoperty grid as per convenience. After drag/drop of object to screen, double click on object to open GUI dialog or select the object and directly enter WHoperties via WHoperty grid available at bottom right corner of screen editor.



#### General

##### **Appearance**

Line Width: Define Line width

Direction: Horizontal or Vertical

##### **Points**

Point1: Define X and Y coordinate for line starting point and they show current position.

Point1: Define X and Y coordinate for line end point and they show current position.

### **Tag Binding**

Select Tag to be linked with this line. This is useful if animation is required to be done on the line.

The screenshot shows the 'Line1 Configuration' dialog box with the 'Animation' tab selected. The dialog is divided into three main sections: 'Movement', 'Size', and 'Tag Value'.  
1. **Movement**: Contains a checkbox for 'EnableMove'. Below it are two columns: 'StartPosition' and 'EndPosition'. Each column has 'X' and 'Y' labels with corresponding input fields. The 'X' fields contain '0' and the 'Y' fields contain '0'.  
2. **Size**: Contains a checkbox for 'EnableSize'. Below it are two columns: 'StartSize' and 'EndSize'. Each column has 'Width' and 'Height' labels with corresponding input fields. The 'StartSize' fields contain '10' and the 'EndSize' fields contain '100'.  
3. **Tag Value**: Contains 'From' and 'To' labels with corresponding input fields. The 'From' field contains '0' and the 'To' field contains '100'.

### **Animation**

***This is to do animation on line in Run Time***

#### **Movement**

Select Enable Move check box if movement animation is required in Run time.

Start Position: Define X and Y coordinate for start position when tag value is minimum in Run Time.

End Position: Define X and Y coordinate for end position when tag value is max. Run time.

Where X position indicates movement from Left side to Right side which is Horizontal movement and Y position indicates movement from Top side to Bottom side which is Vertical movement.

For ex: Recorder 7" (High Performance) WHOject,

800 X 480 pixels,  
Normal installation, Horizontal (Left to Right) = 800 pixels,  
Vertical (Top to Bottom) = 480 pixels

Enable move: Selected  
Start position X = 0, Y = 0  
End position X = 800, Y = 0  
Tag Value, From = 0, Tag Value To = 100

Now, in Run time, when Tag value = 0, then line will be at Top left and when  
Tag value = 100, position of line will be Top Right

### **Size**

Select Enable Size check box to enlarge/decrease size of component in Run time.

Start Size: Define X and Y coordinate for start size when tag value is minimum in Run time.

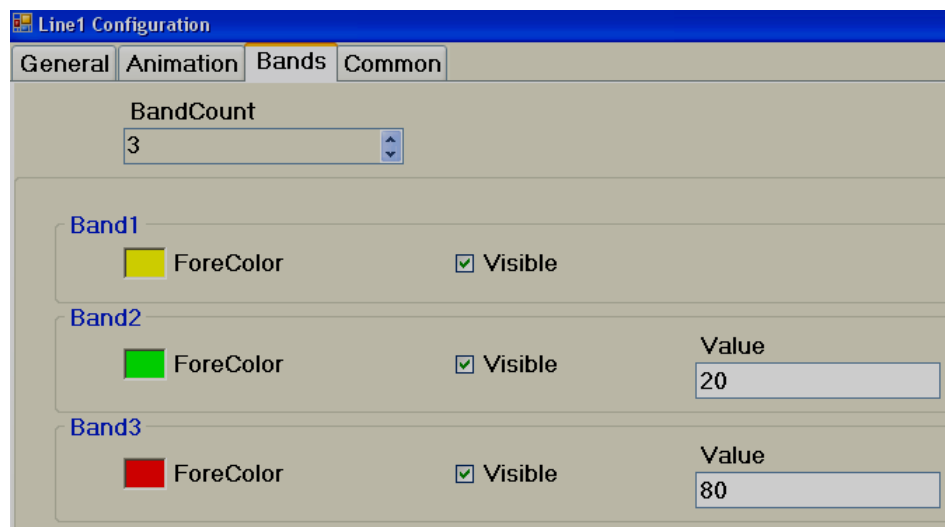
End size: Define X and Y coordinate for end size when tag value is max. Run time.

### **Tag Value**

Select Tag to be linked with this line. This is useful if animation is required to be done on the line.

## **Bands**

***This is to select various bands as pert of animation in Run Time***



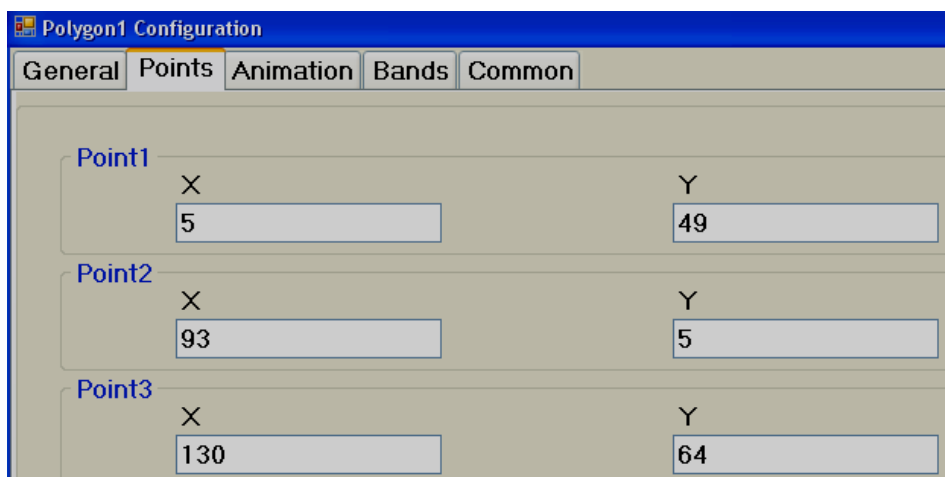
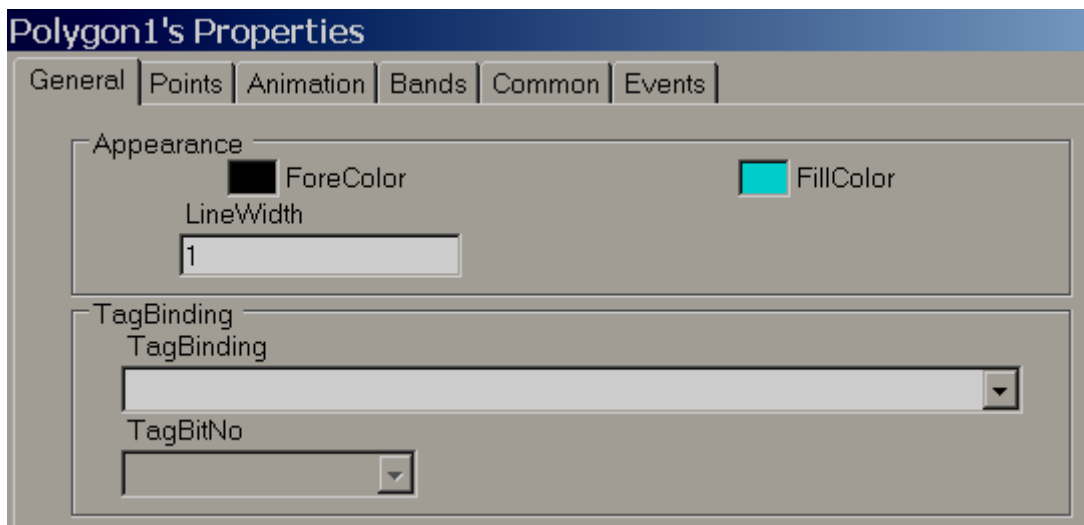
### **Band Count**

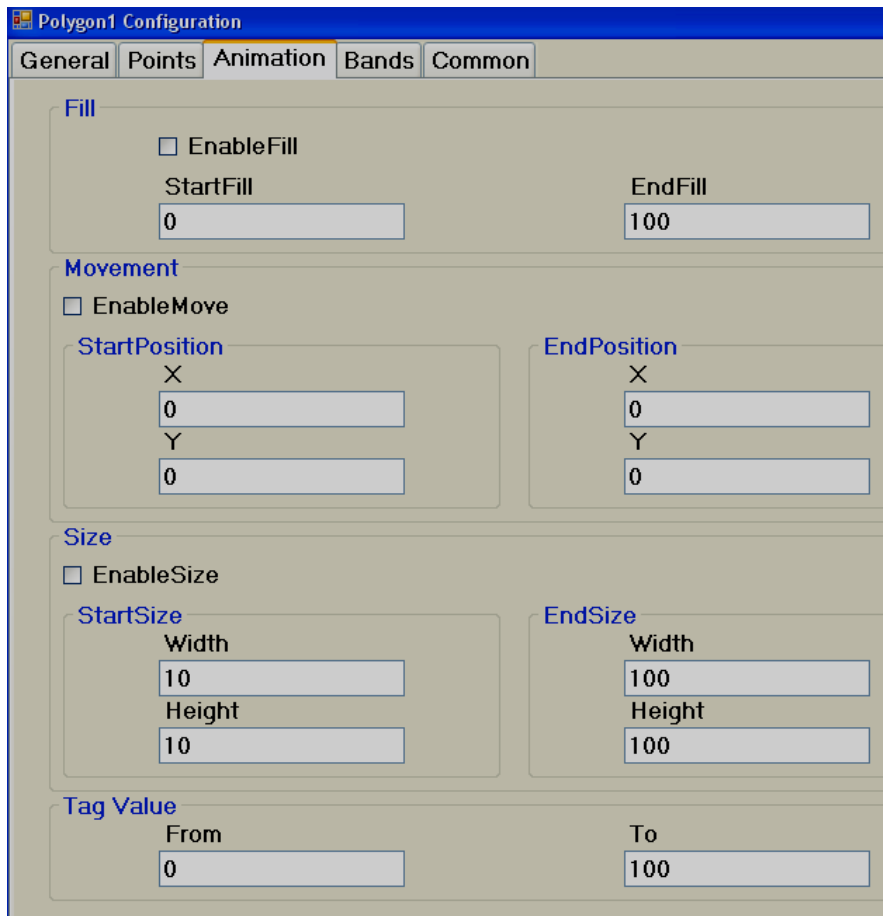
Maximum 32 bands are available.

For ex: In above sample,  
If Tag value is between 0 to 20, line will be in Yellow color  
If Tag value is 21 to 80, then, line color = Green  
If Tag value in Run time is above 80, line color = RED

#### **5.3.17.4 Polygon**

✦ **Polygon:** It is to draw a polygon. After finishing drawing, double click using mouse (left) to complete the Polygon. It is also possible to link polygon to a tag and define user friendly animation to appear in Run time.





## Animation

***This is to do animation on Polygon in Run Time***

### ***Fill***

Select Enable Fill if filling animation is required on Polygon object in Run time. When tag value changes in Run time, it appears filling with defined color inside Polygon object. It is like a bar graph but filling is with in polygon shape defined during design time.

Start Fill: Define Start value for Fill

End Fill: Define End value for Fill

### ***Movement***

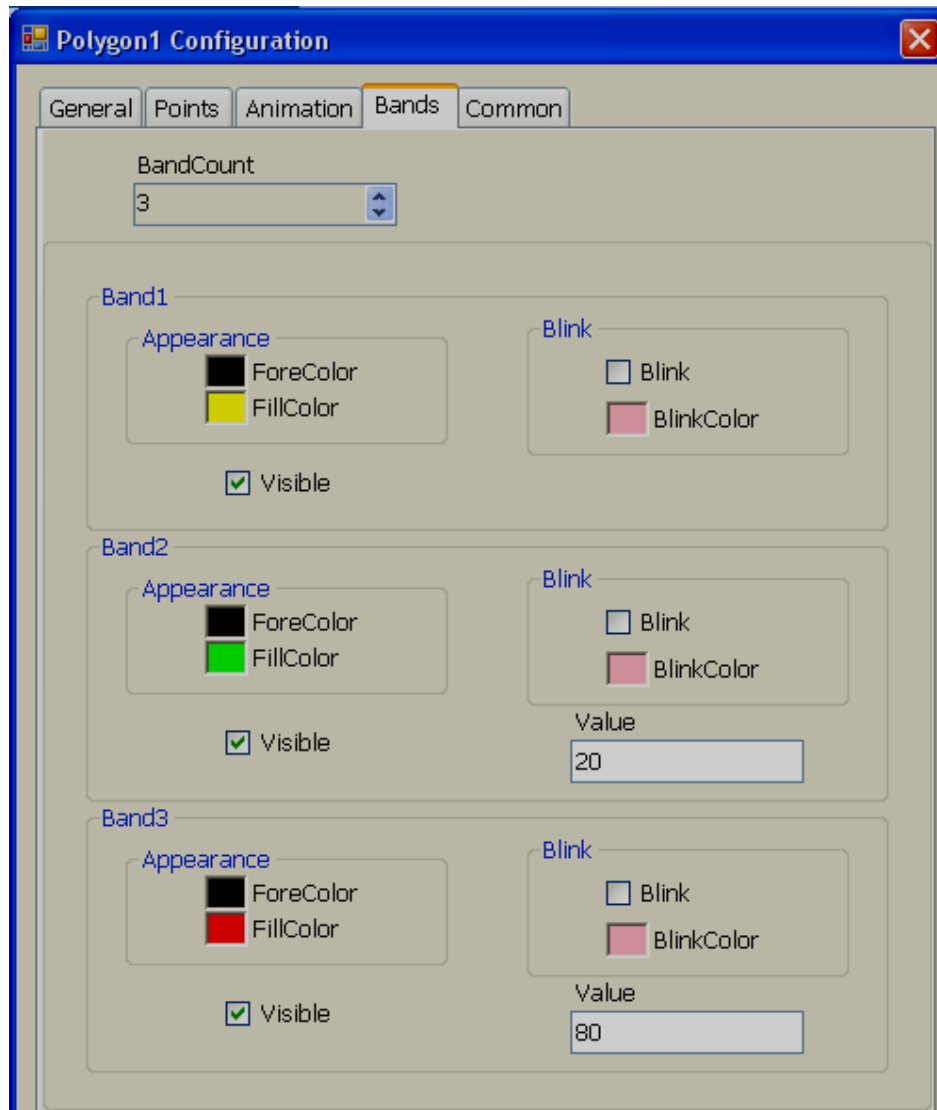
It is to define movement position and it is the same as explained for Line object.earlier.

### ***Size***

It is to define Size enlarge/decrease and it is the same as explained for Line object earlier.

### ***Tag Value***

Select Tag to be linked with Polygon object. This is useful if animation is required to be done on the Polygon.



Band editor: Maximum 32 bands are available.

For example: In above sample,

If Tag value is between 0 to 20, Polygon fill color = Yellow

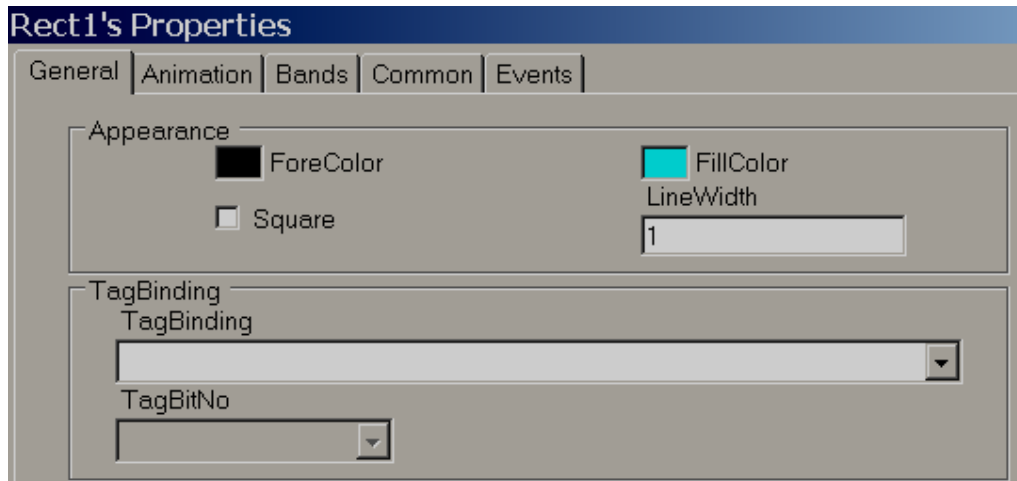
If Tag value is 21 to 80, then, Polygon fill color = Green

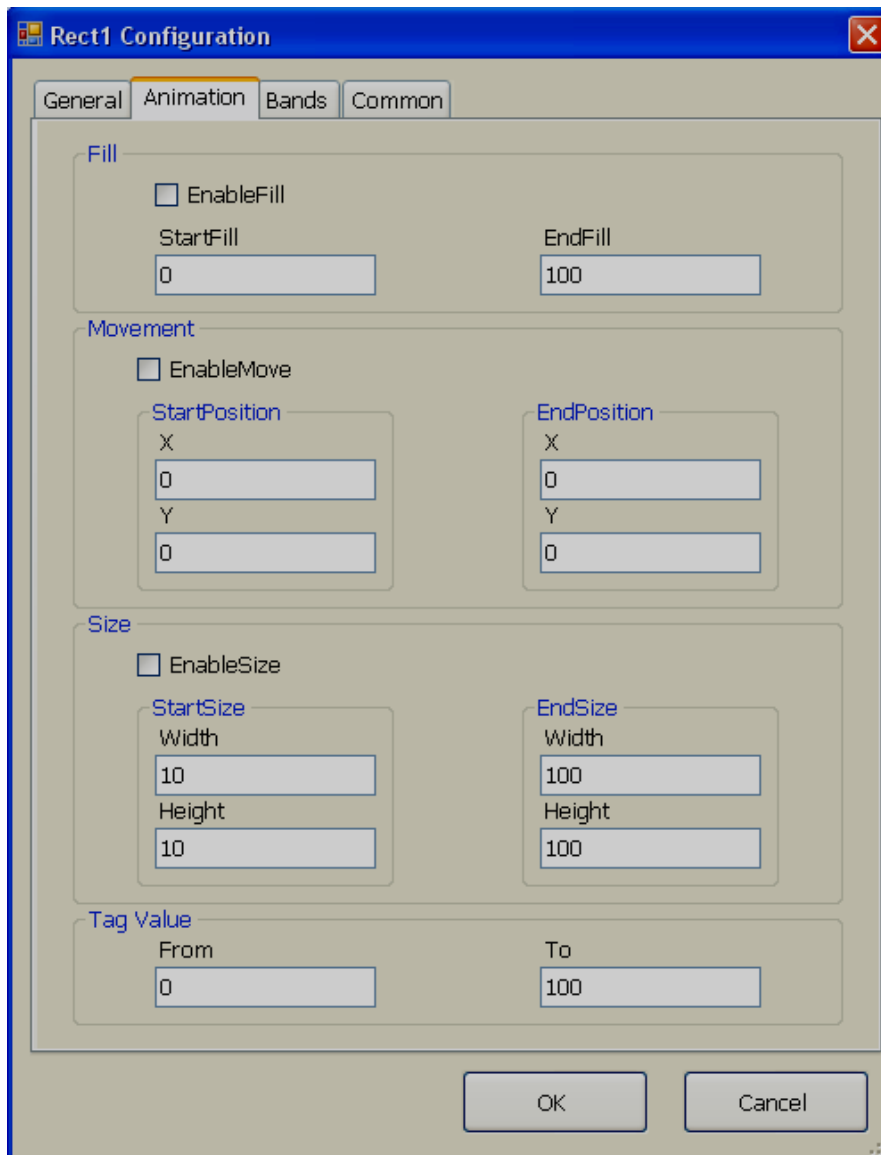
If Tag value in Run time is above 80, Polygon fill color = RED

If required, it is also possible to configure blink WHoperty and set blink color in any band.

### 5.3.17.5 Rectangle

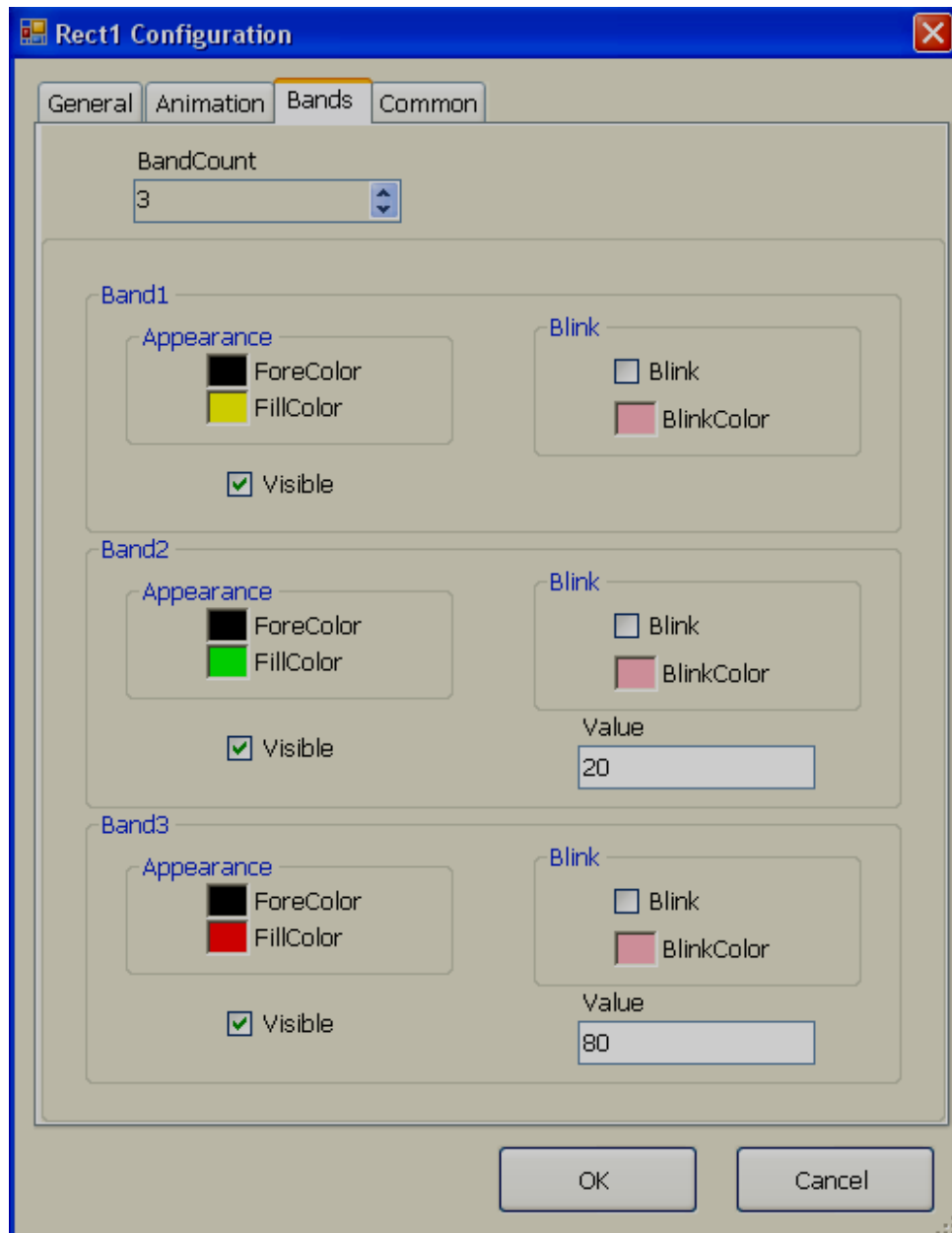
**Rectangle**: It is to draw a Rectangle and do animation in Run time linking with Tag.





Animation Supported: Fill, Movement and Size

The above features are same as explained for Line and Polygon objects



Band editor: Maximum 32 bands are available.

For ex: In above sample,

If Tag value is between 0 to 20, Rectangle fill color = Yellow

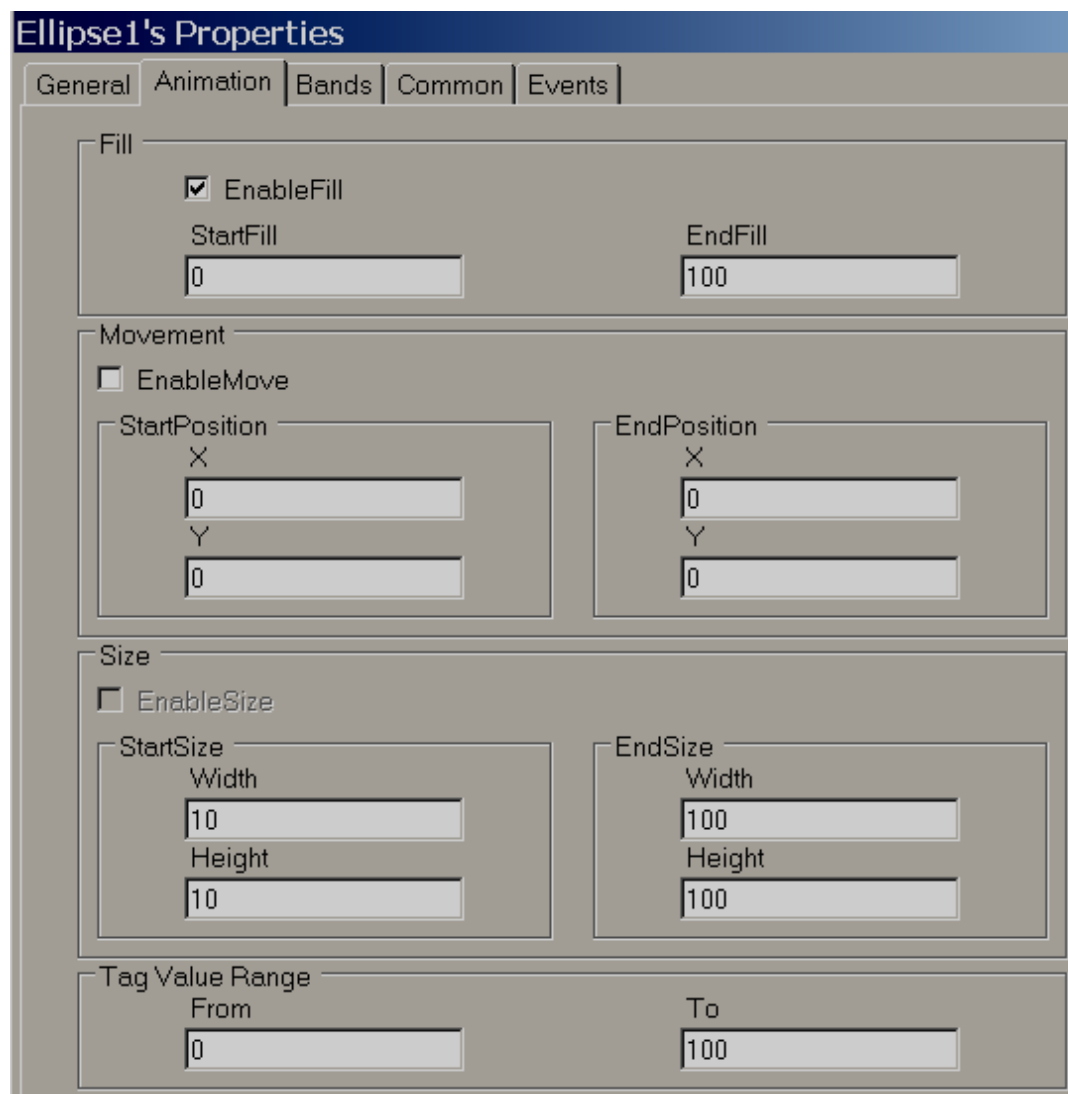
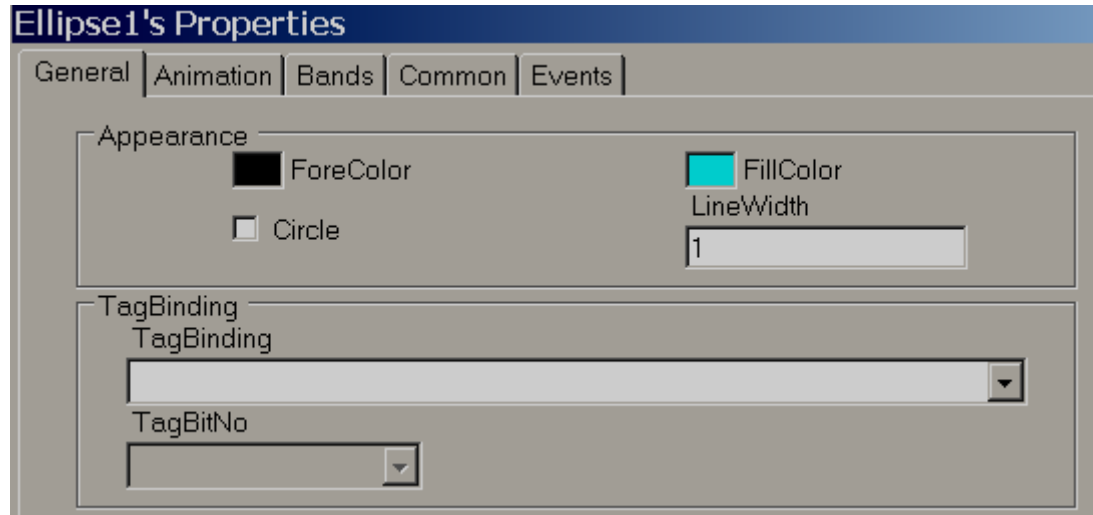
If Tag value is 21 to 80, then, Rectangle fill color = Green

If Tag value in Run time is above 80, Rectangle fill color = RED

If required, it is also possible to configure blink WHoperty and set blink color in any band.

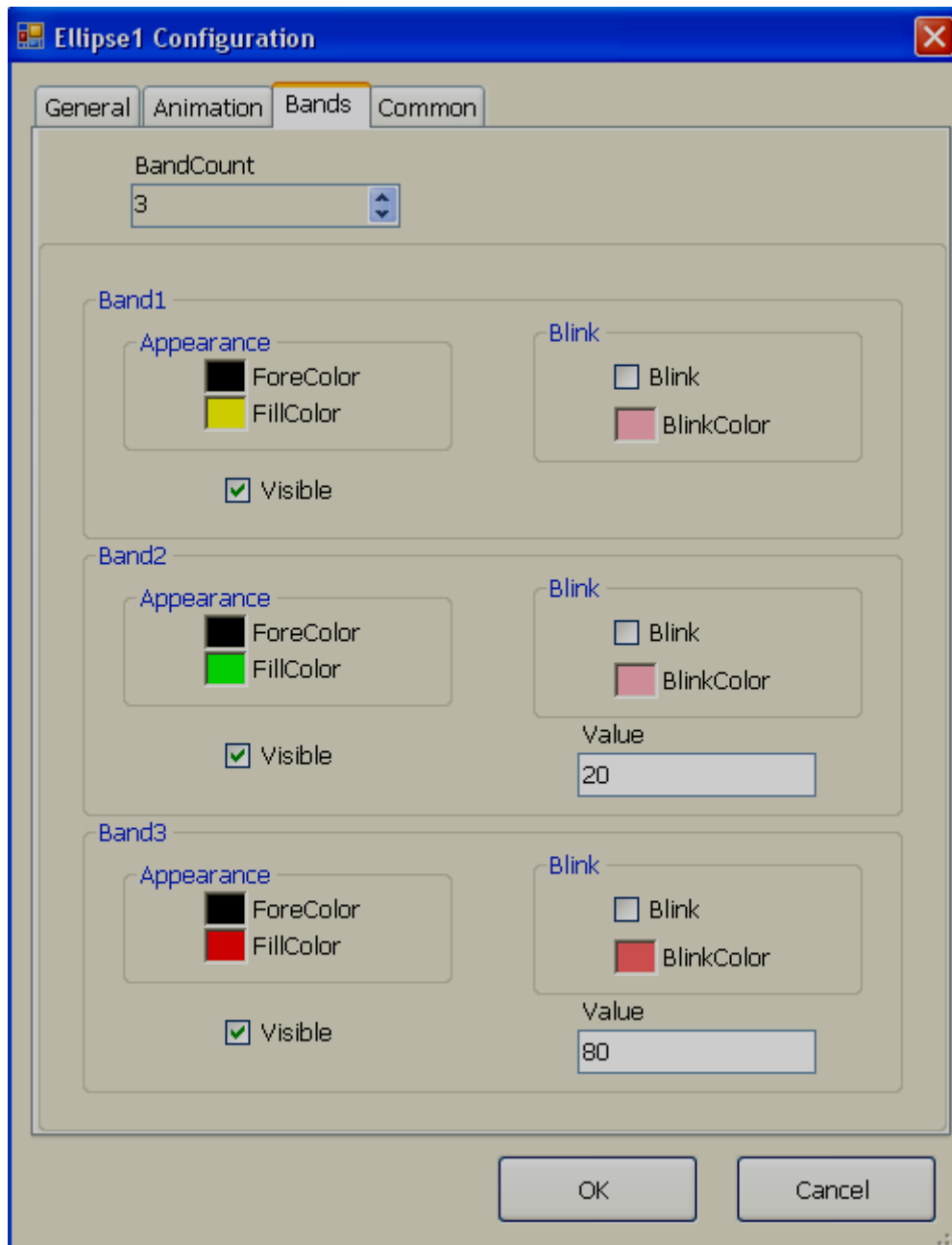
### 5.3.17.6 Ellipse

**Ellipse:** It is to draw Ellipse or a circle and do animation in Run time linking with a Tag.



Animation Supported: Fill, Movement and Size

The above features are the same as explained for Line and Polygon objects.



Band editor: Maximum 32 bands are available.

For example: In above sample,

If Tag value is between 0 to 20, Ellipse fill color = Yellow

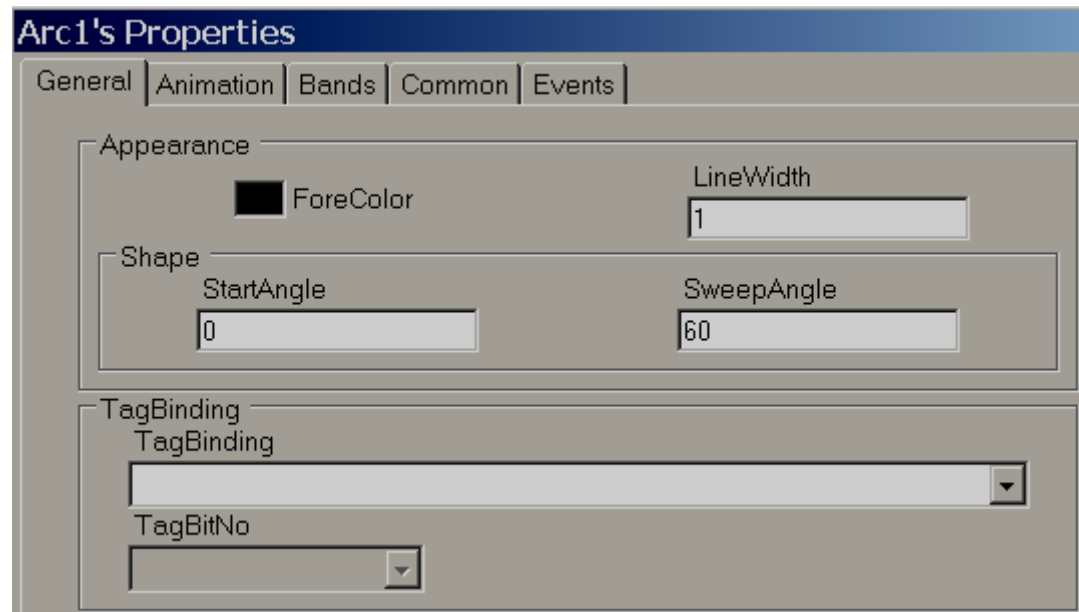
If Tag value is 21 to 80, then, Ellipse fill color = Green

If Tag value in Run time is above 80, Ellipse fill color = RED

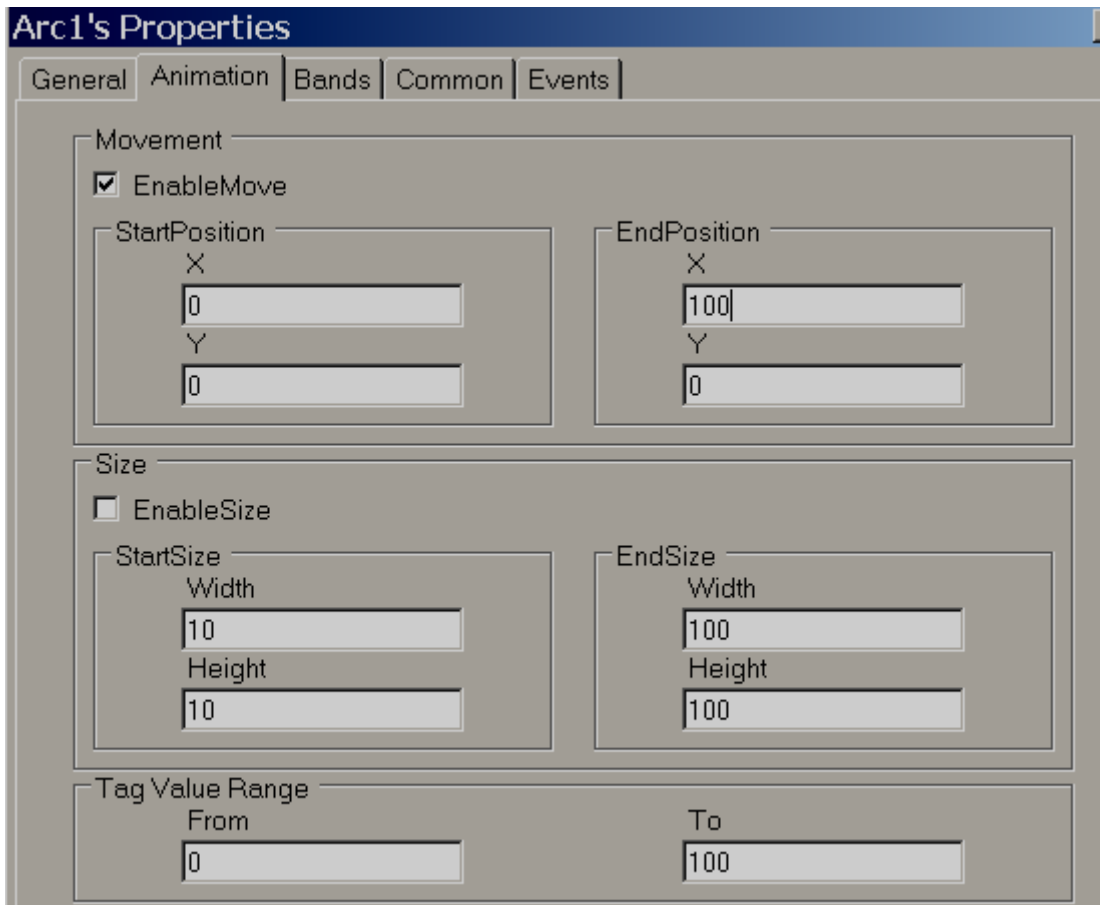
If required, it is also possible to configure blink WHoperty and set blink color in any band,

### 5.3.17.7 Arc

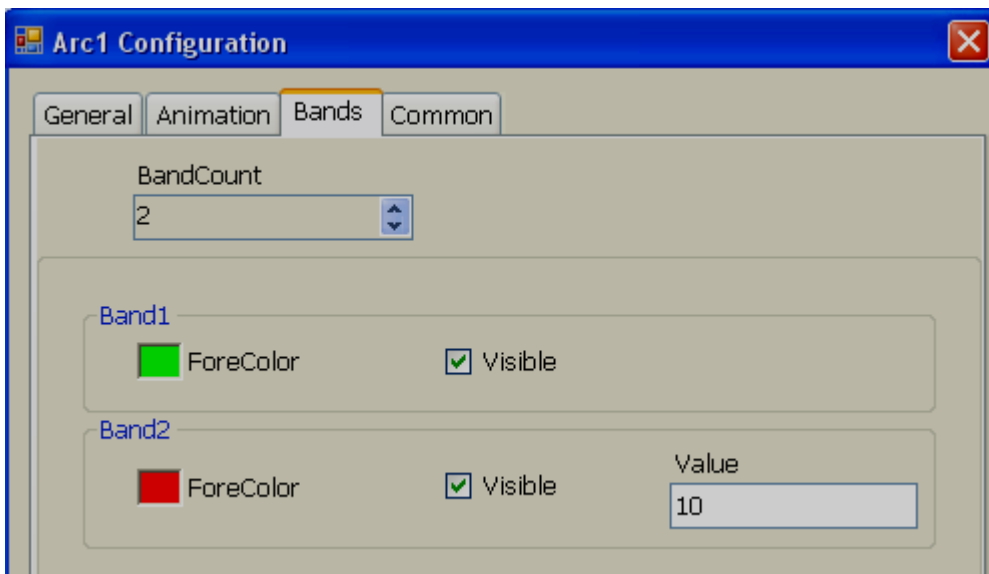
⤿ **Arc:** It is to draw Arc and do animation in Run time linking with Tag.



Start Angle: Define start angle, Sweep angle: Define end angle



Supported Animation: Movement and Size



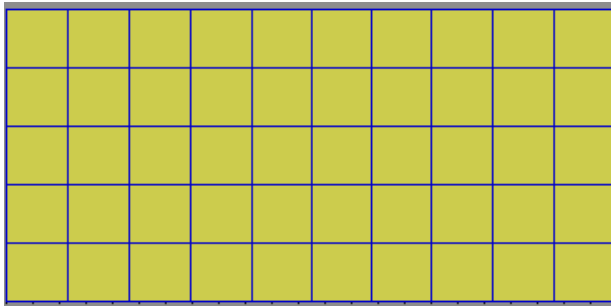
Band editor: Maximum 32 bands are available. Band editor for Arc is the same as explained for "Line" object earlier.

### 5.3.17.8 Table

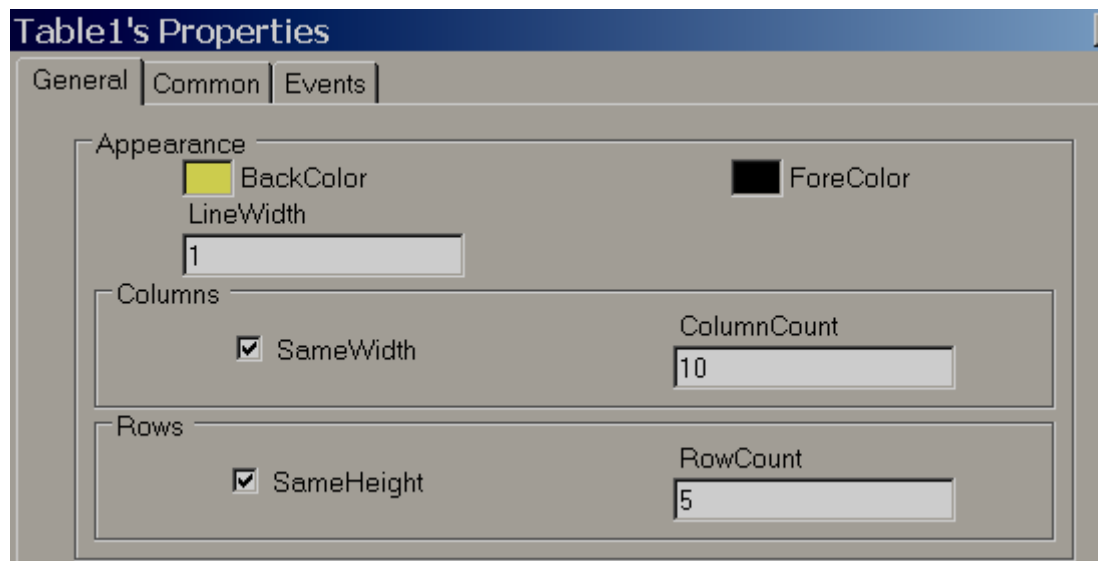
It is to draw a table in design time by specifying number of rows & columns. All rows/columns will have the equal width and height. It is possible to place labels on rows (Linked with Tags) for displaying WHocess values to appear like a tabular column. User can edit WHoperties via GUI dialog or WHoperty grid as per convenience. After drag/drop of the object to screen, double click on object to open GUI dialog.



While working with Table, in page WHoperties, select Snap to Grid = False such that it is easy to place labels/ Textbox in required position easily.



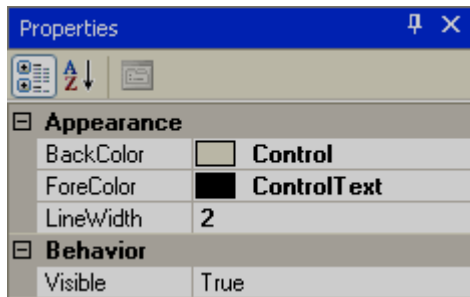
Drag/Drop Table from Basic objects to screen and double click on Table. Following screen will open.



Note: Deselect “Same Width” to adjust column width in the Table

Note: Deselect “Same Height” to adjust Row height in the Table

## WHoperty grid



Design	
(Name)	Table1
Columns	5
Locked	False
Rows	5
Layout	
Dock	None
Location	80, 192
Size	480, 176

## WHoperties

**Back Color:** It is back color for the table

**Fore Color:** It is color for the lines in table

**Line Width:** It is the width of lines

**Columns:** It is to define number of columns in table

**Rows:** It is to define number of rows in table

**Name:** It is the unique name for the table in specific page

**Locked:** It is to determine if table is locked for further moving and resize in design time and you can set this in WHoperty grid.

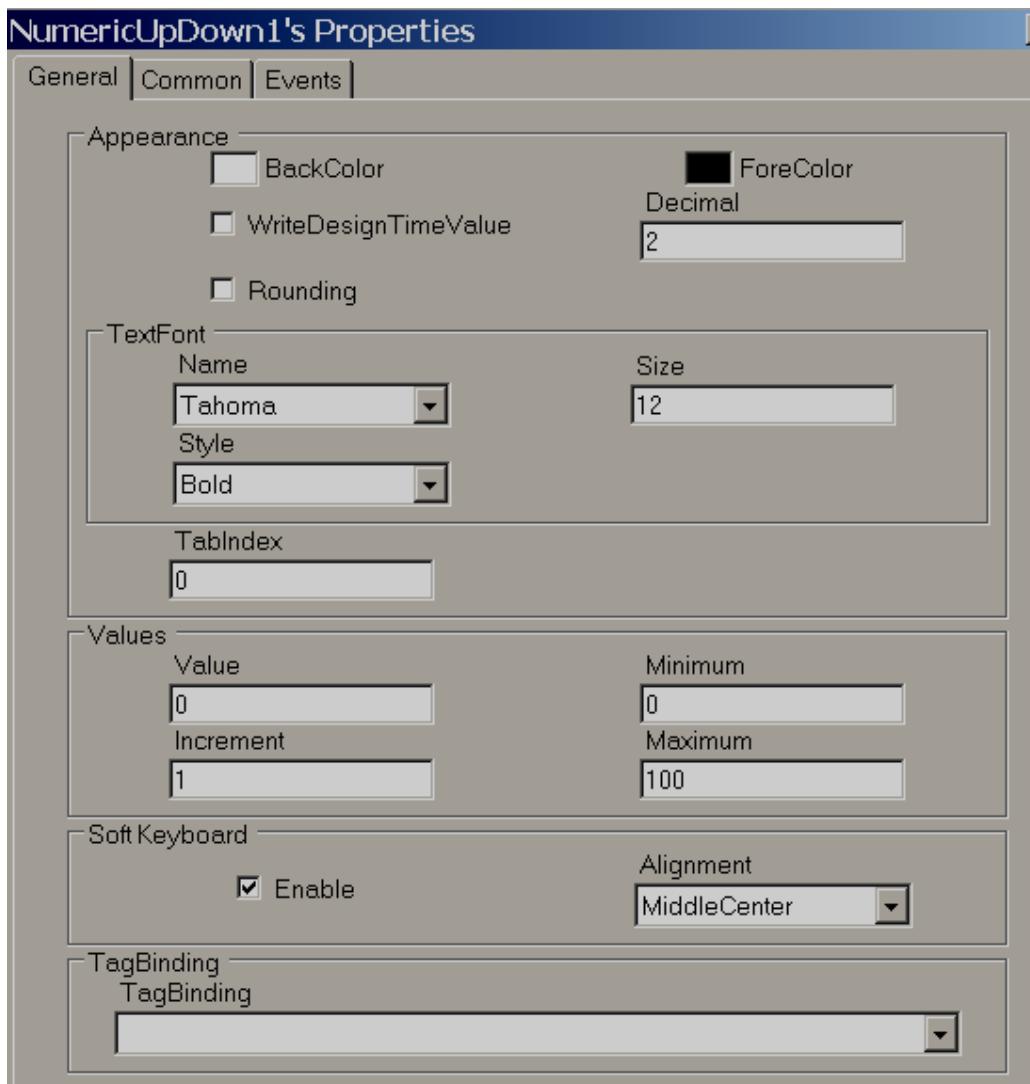
### 5.3.17.9 Numeric Up/Down

Numeric Up/Down is Graphical User Interface widgets that allow the user to increase or decrease value of a tag by WHessing Up or Down arrows in Run time or alternatively enter numeric value directly via keypad. User can edit WHoperties via GUI dialog or WHoperty grid as per convenience. After drag/drop of object to screen, double click on the object to open GUI dialog.

Every Numeric Up/Down button should be linked with an **Analog** Tag.



Except Up/Down arrow, if user WHesses another area of Numeric Up/Down component in Recorder at Run time, Numeric keypad will open. Then, user can enter numeric value directly. Numeric Keypad will not appear in PC during Online/Offline simulation and you can use keyboard directly to enter numeric value.



Increment: Select the value to be incremented/ decremented each time when up/down arrow is WHessed in Run time.

### **WHoperties**

**Write design time value:** If selected, it writes value available at “Text” in design time and also in run time replacing default value defined at Tag data base.

**Rounding:** Rounding to nearest value

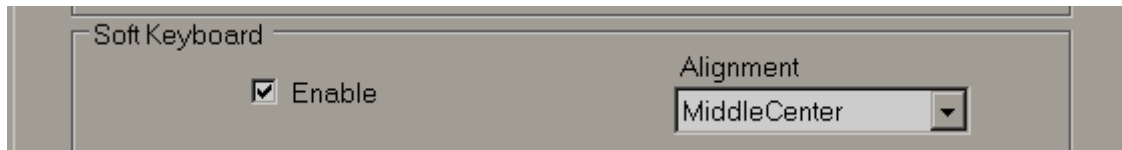
**Decimal:** Enter number of decimal points

**Value:** Current Tag value. It is used to enter value in design time and check how value is displayed in Run time.

**Increment:** Value to be incremented in Run time after WHessing Up/Down button.

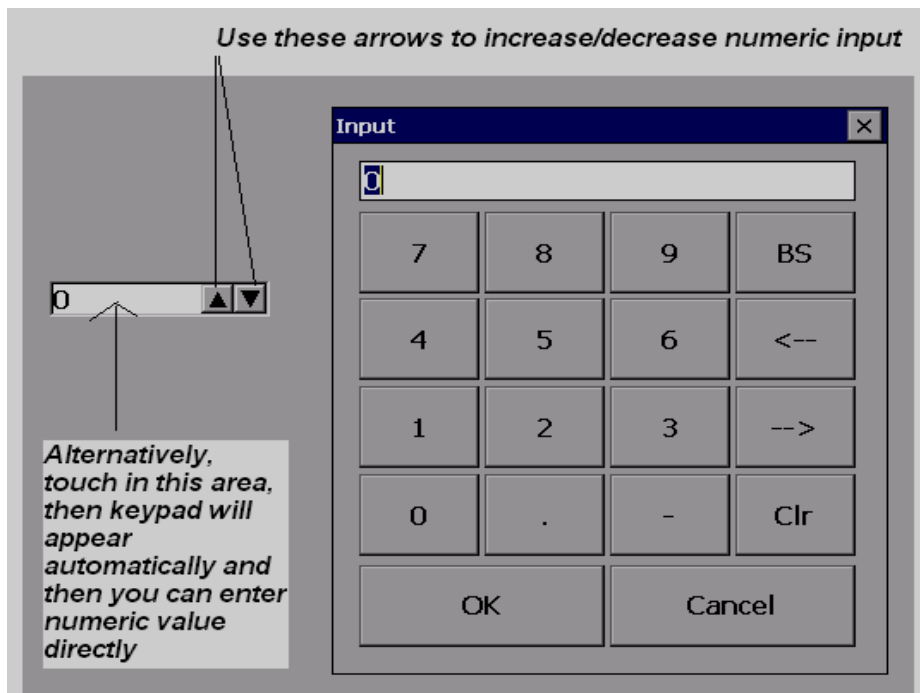
**Minimum:** Define Minimum value

**Maximum:** Define Maximum value



**Soft keyboard:** If enabled, then, it is possible to control the keypad appearance in run time. For example, if alignment is selected as Middle center, then, when keypad appears in run time, it will be located to Middle center in screen

**Events:** Define events to be executed when operator WHessed on Up/Down arrow and value changes occurs in Run time.



### 5.3.17.10 Digital LED

It is to view WHocess value in Digital format. Generally it is linked with Analog type tag (Analog input type tag at PLC, which is received as 4-20 mA signals from field transmitters like Temperature, WHessure, Flow, Level, Position etc...)



For common WHoperties like Back Color, Bevel, please refer section “Common WHoperties

**DigitalLED1's Properties**

General | Common | Events

Appearance

BackColor Value: 1

Bevel

InnerBorder  OuterBorder

Style: DoubleRaised

Digits

ActiveColor  InactiveColor

DigitHeight: 80 DigitWidth: 40

DigitSpace: 3 SegmentSpace: 1



SegmentThickness: 4

Decimal: 0  Rounding

TagBinding

TagBinding: [Empty dropdown]

### WHoperty grid

Dgits		Red,80,3,40,Color [Silver]
ActiveColor		Red
DigitHeight		80
DigitSpace		3
DigitWidth		40
InactiveColor		Silver
SegmentSpace		1
SegmentThickness		10

### WHoperties

**Back Color:** Define background color for the component

**Inner border:** Select if inner border is required for the component

**Outer border:** Select if outer border is required for the component

**Style:** Define border style. Available options are Single, Double, Raised, Lowered, Double Raised, Double Lowered, Frame Raised and Frame Lowered

**Active Color:** Define Active Color of Segment for Digits

**Inactive Color:** Define color of inactive segment. In the seven-segment LED display, some segments might be active and some other segments might be inactive depending numeric value.

**Digit Height:** Define Height of Digits

**Digit Width:** Define width of Digits

**Digit Space:** Define Space between digits

**Segment Space:** Define space between segment to segment for digits

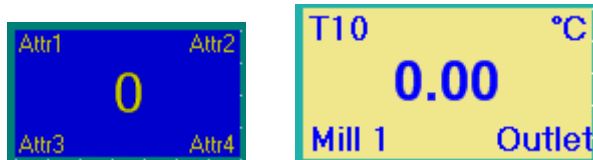
**Segment Thickness:** Define thickness of segments for digits

**Decimals:** Define number of decimal points

**Tag Binding:** Select the Analog Tag of WHocess value



### 5.3.17.11 Digital Box

Digital Box is a Graphical User Interface widget that displays Digital Tag value along with four WHedefined labels as attributes for the WHocess value in Run time.



Every Digital Box normally used with **Analog** Tag to display WHocess values like Temperature, WHessure, Flow etc., It also allows 4 different labels as attributes for displaying tag related information.



<b>Appearance</b>	
Attribute1	T10
Attribute2	*C
Attribute3	Mill 1
Attribute4	Outlet
AttributeFont	Microsoft Sans Serif
BackColor	 Khaki
Decimal	2
ForeColor	 Blue
ValueFont	Arial,20,Bold

<b>Behavior</b>	
Value	0
Visible	True
<b>Data</b>	
TagBinding	Tag3
<b>Design</b>	
(Name)	DigitalBox1
Locked	False
<b>Layout</b>	
Dock	None
Location	176, 224
Size	256, 112

## WHoperties

**Attribute1:** attribute to be displayed at Top left side of Digital Box

**Attribute2:** attribute to be displayed at Top Right side of Digital Box

**Attribute3:** attribute to be displayed at Bottom Left side of Digital Box

**Attribute4:** attribute to be displayed at Bottom Right side of Digital Box

**Attribute font:** Define font for attribute, select type of windows font, size of font and style of font which includes Regular, Bold, Italic, Underline, and Strike out.

**Back color:** Define back ground color

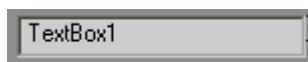
**Fore Color:** Define fore color for the font

**Decimal:** Define number of decimal places for the value to be displayed

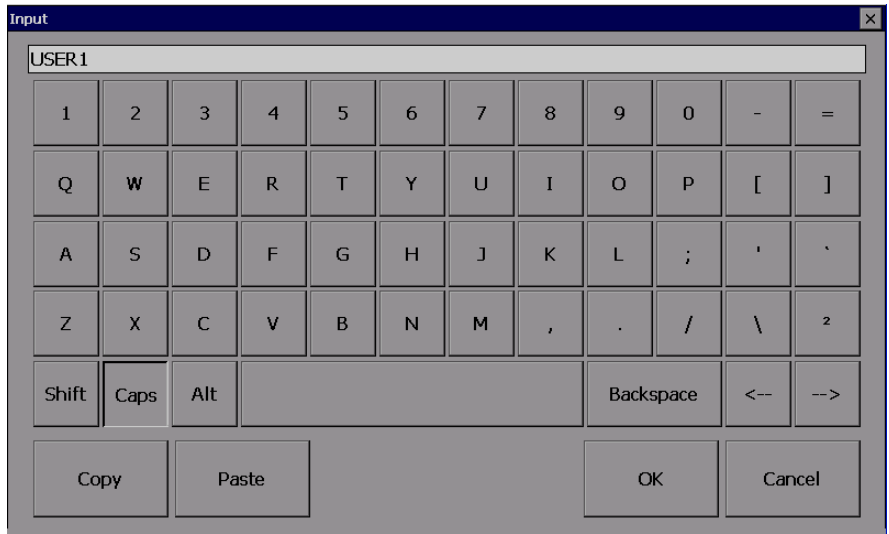
**Value font:** It is to adjust size of display WHocess value font, select type of font, size of font and style of font including Regular, Bold, Italic, Underline and Strike out.

### 5.3.17.12 Text box

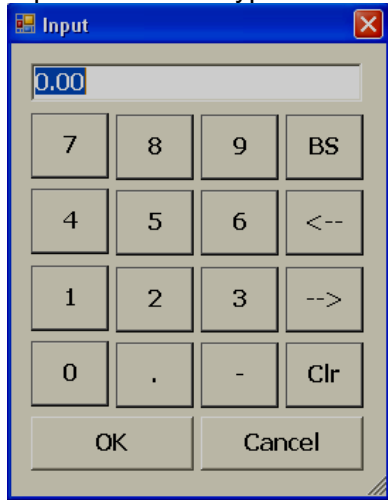
It is to Read/Write, Alpha numeric text in Run time. It can be linked with any type of tag.



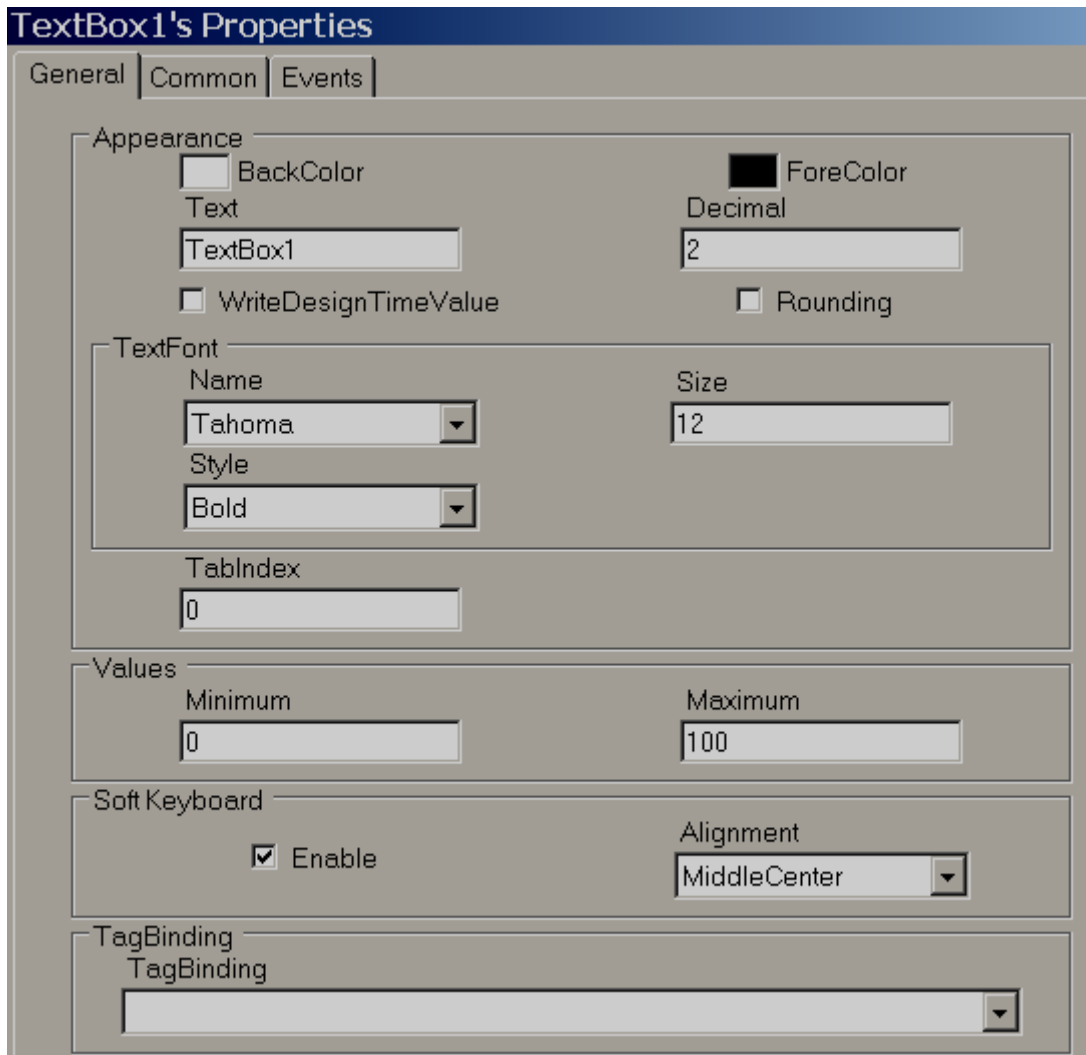
If object is linked with String type tag, then, Alpha numeric keypad opens in Run time if users touch on object. If object is linked with Analog or Digital tag, then, numeric keypad opens in Run time if user attempts to touch on object. If Digital tag is used, then, make sure decimals are set to 0.



Alpha numeric keypad

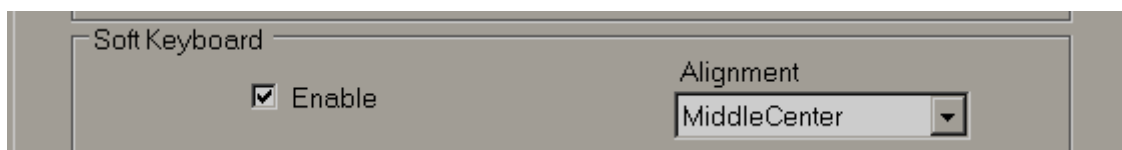


Numeric keypad



Note: For common WHoperties of all the components, please check beginning of this section.

**Write design time value:** If selected, it writes value available at “Text” in design time and also in run time replacing default value defined at Tag data base.



**Soft keyboard:** If enabled, then, it is possible to control the keypad appearance in run time. For example, if alignment is selected as Middle center, then, when keypad appears in run time, it will be located to Middle center in screen

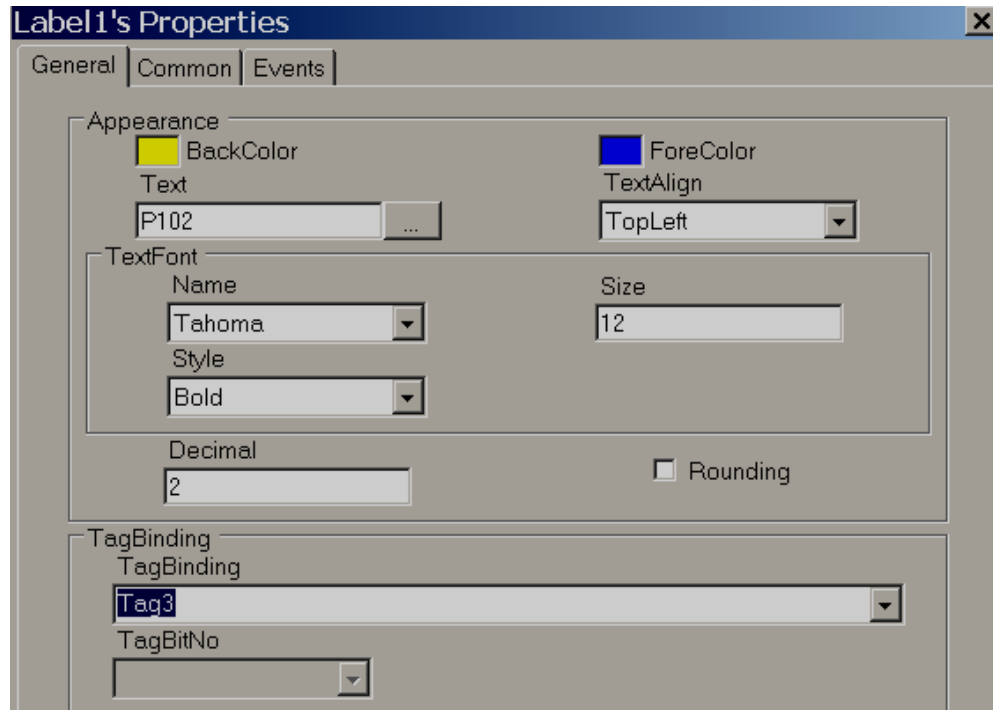
[-] Appearance	
BackColor	<input type="checkbox"/> White
Decimal	2
ForeColor	<input checked="" type="checkbox"/> ControlText
Password	
Text	TextBox1
[-] TextFont	
Tahoma,12,Bold	
[-] Behavior	
Visible	True
[-] Data	
TagBinding	Tag1

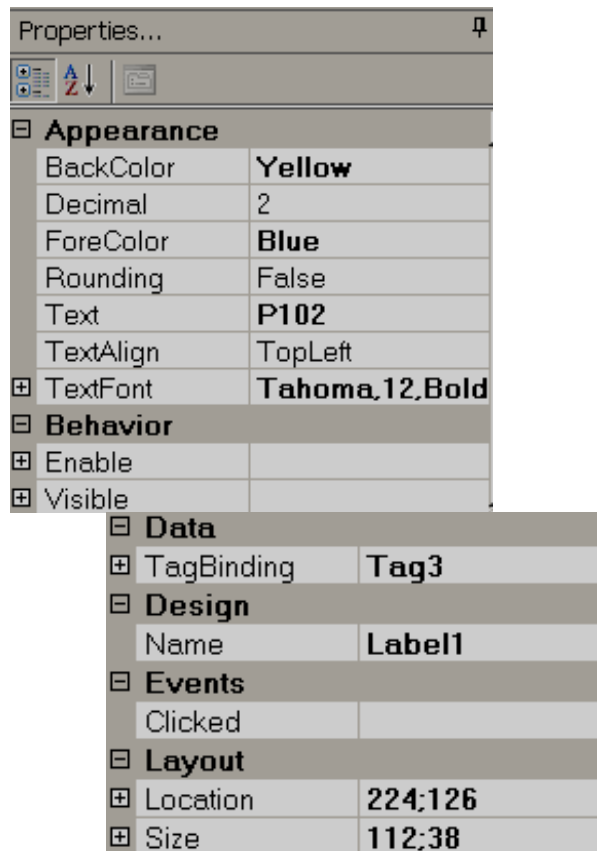
[-] Design	
(Name)	TextBox1
Locked	False
SecurityLevel	0
[-] Events	
Changed	
[-] Layout	
Dock	None
[-] Location	
96, 96	
[-] Size	
112, 24	
[-] Misc	
WriteDesi	False

### 5.3.17.13 Label

Label is to write a simple text for user information in the screen to improve clarity for the operator. Example: Tag name, Pump number display etc. It is also used to display process value (read only) to operators by linking with Tag.

P102





Note: For common WHoperties of all the components, please check beginning of this section.

### **WHoperties**

**Text:** Define text associated with this component and it should be entered at design time only.

**Text Align:** It is for Alignment of text and available options include Top Left, Top Center, Top Right, Middle Left, Middle Center, Middle Right, Bottom Left, Bottom Center and Bottom Right

**Text Font:** Define font for text including type of font, size of font and style of font. Styles include Regular, Bold, Italic, Underline and Strikeout.

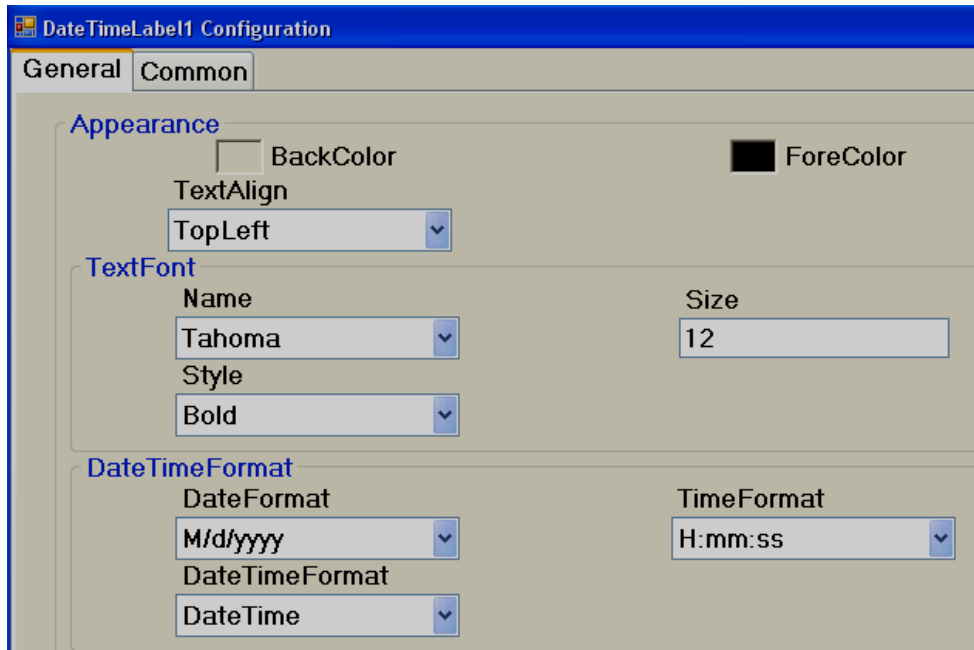
**Tag Binding:** Select the Analog Tag of WHocess value

**Decimal:** Define number of decimal points

### 5.3.17.14 Date and time Label

1/20/2010 PM 4:43:03

It is to display Date and Time in screen.



If date and time required in more than one screen, it is better to create screen and select screen type as “Template” and then link this template to all other required screens to display Date and Time automatically. This is more efficient than keeping Date and Time label in more than one screen.

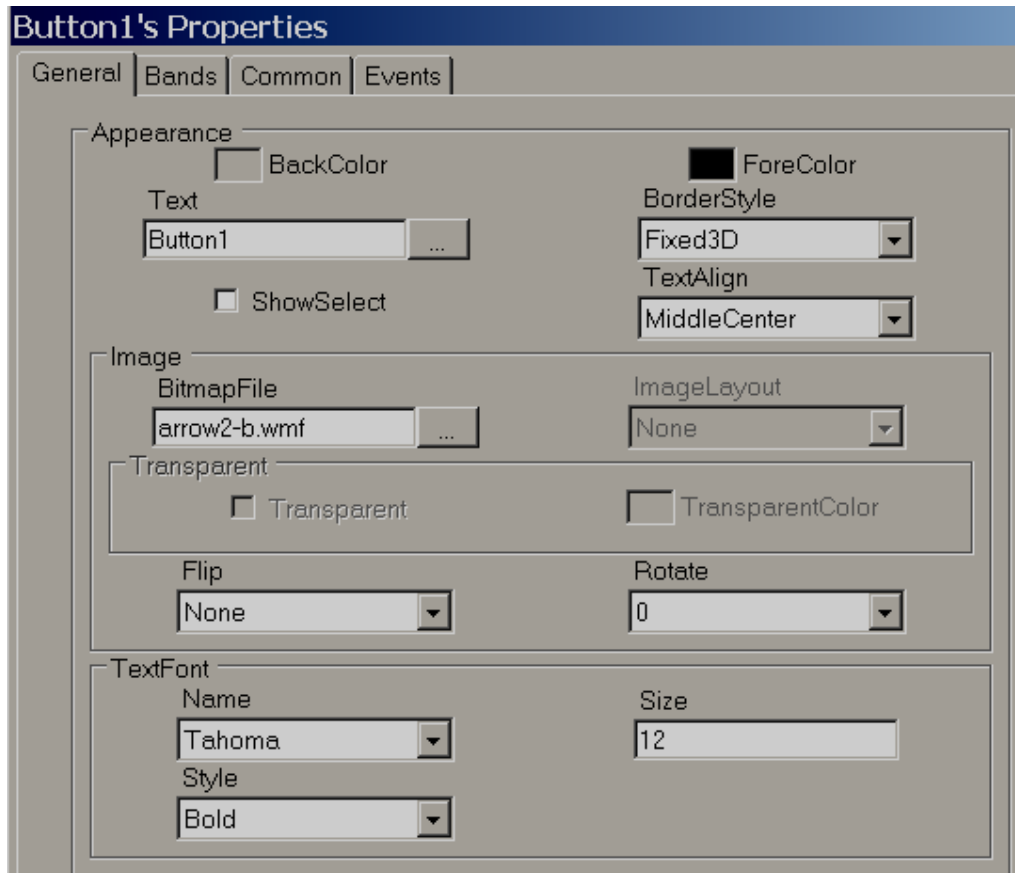
### 5.3.17.15 Button



A Button is commonly used to perform an action after operator WHesses it via finger or by clicking using a mouse in Run time.

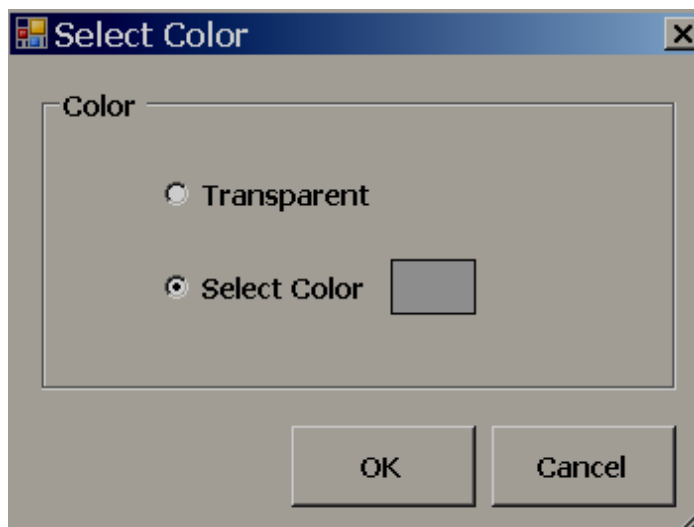
Generally button is used to turn ON a bit, Turn OFF a bit etc. used with Digital type tags. Example: Start Pump, Stop pump etc.

Three kinds of events supported for a button. Clicked, WHessed and Released. Several functions are supported which can be configured from Events and all the functions are covered in next section “Function editor”.

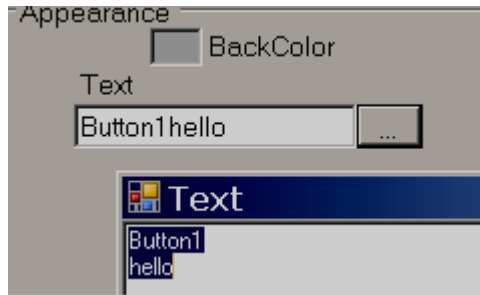


### WHoperties

**Back Color:** Selects Back color for the object. Also, it is possible to select transparent mode if required from V1.20 onwards



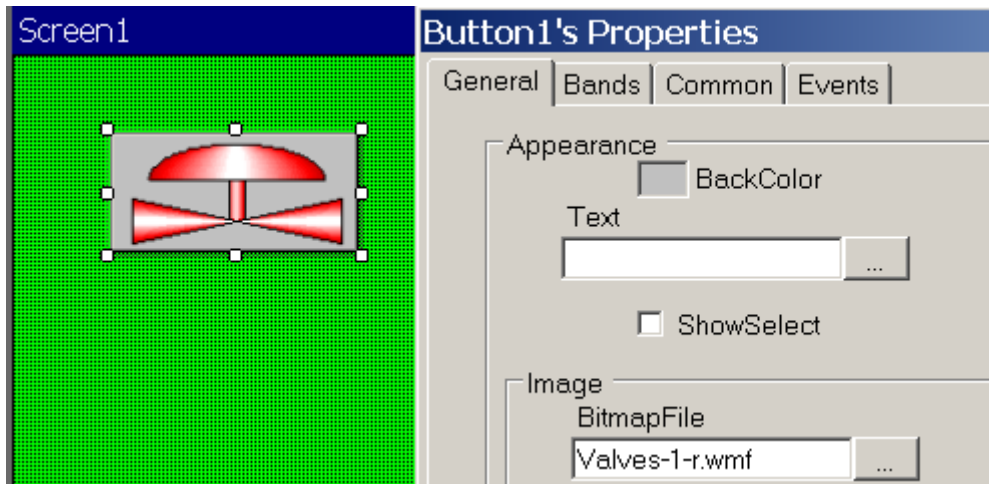
**Text:** Define required text to be displayed on the object. It is also possible to enter multiline text from V1.20 onwards



**Show select:** True/False. If it is selected, then, when operator WHesses this button, it will show dotted line just inside the button. When operator WHesses another button, it automatically shows selected "show" status to latest button and deselect "select" status for WHevious button WHessed by the operator.

**Border Style:** Define border style. Available options include none, fixed single and fixed 3D

**Image:** Select the Image to be displayed on top of the object. Image can be selected either from Basic symbols or Symbol factory or custom image in formats of bmp, wmf, jpg, gif and png



**Text font:** Define the font including name of font, size of font and style of font

The image shows a configuration dialog box with three main sections:

- Timing - Clicked:** Contains a checkbox for "Hold" (unchecked) and a text input field for "HoldTime (ms)" with the value "50".
- Timing - Pressed:** Contains a checkbox for "AutoRepeat" (unchecked) and a text input field for "Interval (ms)" with the value "50".
- TagBinding:** Contains two dropdown menus. The first is labeled "TagBinding" and the second is labeled "TagBitNo". Both are currently empty.

**Timing:** This is an advanced feature and used to make sure operator action is properly received by PLC when PLC scan time is large.

**Hold time:** This is generally applicable for "Click" event. This keeps on executing action defined at Clicked event for the time defined at hold time. We suggest using holding time of button more than PLC scan time. Example: 300 msec.

Example:

### **Push button Function**

The image shows the "Button1 Configuration" dialog box with the "Events" tab selected. It displays the following configuration:

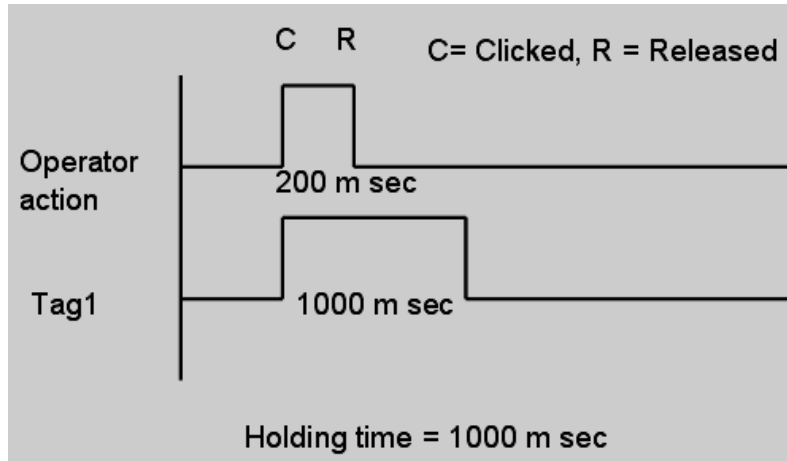
- Clicked:** TurnBitOn(Tag1);
- Pressed:** (Empty)
- Released:** TurnBitOff(Tag1);



Example: Operator presses button for only 200 msec. When operator clicks button, Tag1 = 1 and when operator releases button, Tag1 = 0, holding time = 1000 msec.

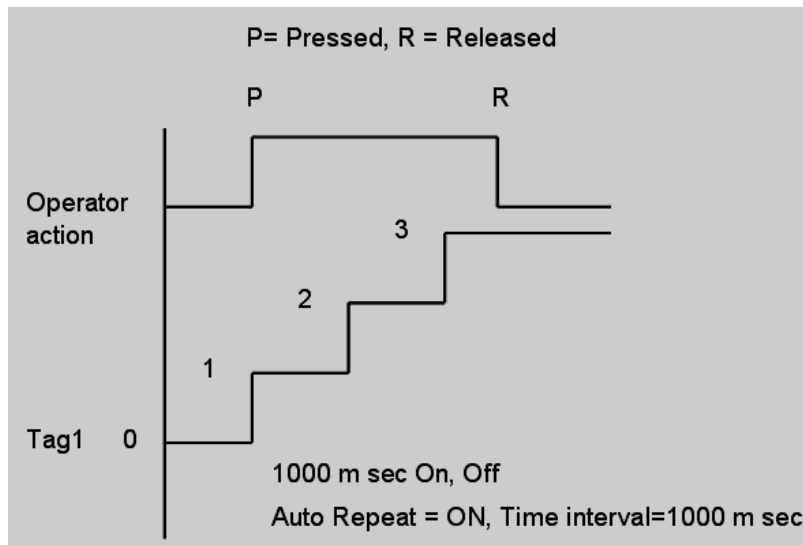
Since holding time is set for clicked action, released action, "TurnBitOff" will be executed only after completing 1000 msec but not

immediately after operator releases the button. In this case, if PLC scan time is 800 msec, and still operator click action will be detected properly because operator command will be available for 1000 msec.



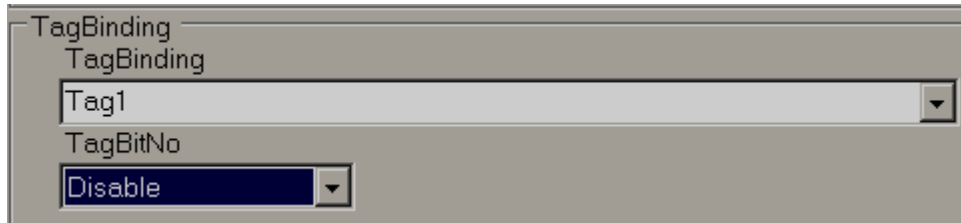
**Auto Repeat & Interval time:** This is generally applicable for “WHessed” event. It is to repeat the action defined at “WHessed” event as per set interval time.

Example: When operator keeps WHessing button, set point should be incremented by 1 for every 1 sec and Tag1 is Integer type.

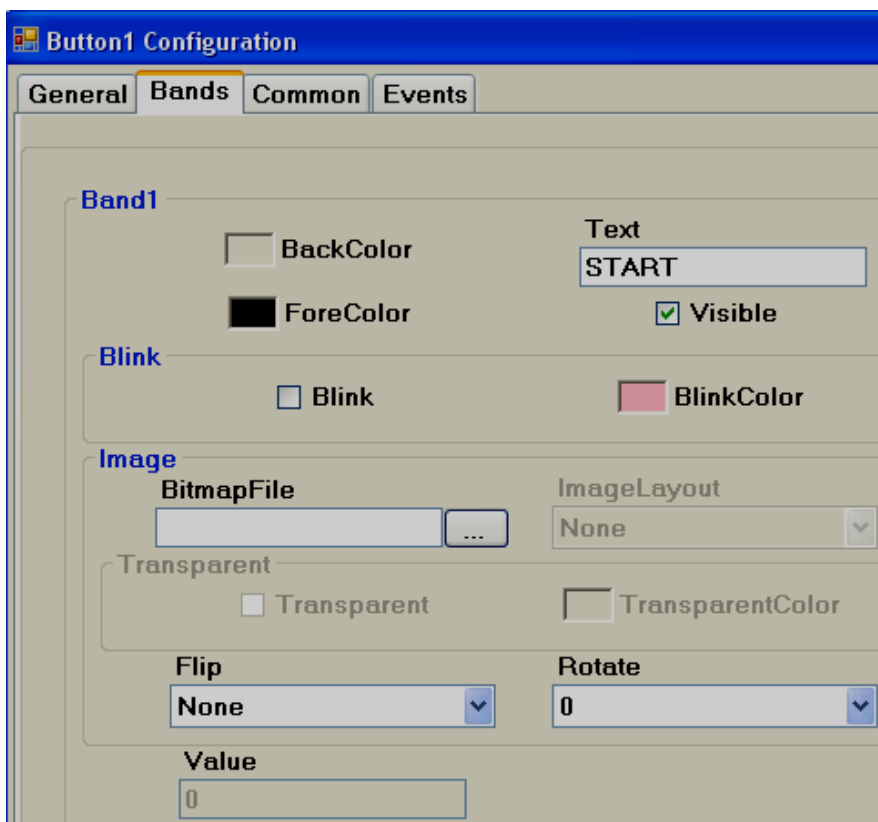


Auto repeat with time interval and holding time cannot be used together.

**Tag binding:** Select the tag that should be linked with the button to show different display in run time based on configuration available at Band editor. Both Analog



If Tag1 is Analog Type (32 bit), it is also possible to show different display based on individual bits. By default, it is disabled. You can select the bit from the combo box and then configure band editor as per WHOject requirements.



**Bands:** Define bands for the button.

**Back color:** Define back color for the selected band

**Fore color:** Define fore color to appear for selected band in run time

**Text:** Define the text to be displayed for selected band in run time

**Visible:** Control the visibility

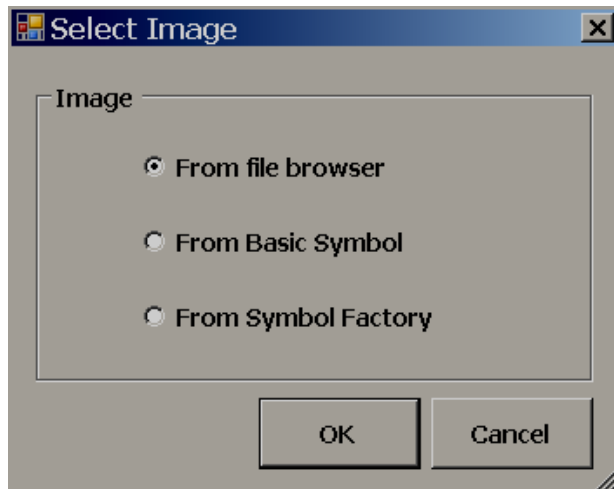
**Blink:** Select if blink is required when tag value reaches selected band in run time. If yes is selected, then, it allows to enter blink color as well.

**Bitmap file:** Select the image to be displayed on button when tag value reaches this band in run time.

For example: When Tag1=0, show Red color motor symbol on button.  
When Tag1=1, show Green color motor symbol on button.

Note: Two different symbols are required for the above

Bmp, wmf, jpg, gif and png types are supported. If selected file is other than wmf, then, it is also possible to select Image layout and transparent options.



**From File browser:** It is to select image from required location

**From Basic Symbol:** It is to select images from free basic symbols (\*.wmf format) available in Recorder editing software.

**From symbol factory:** It allows to select symbol from symbol factory in wmf format

**Image layout:** None, center and Stretch options are available. Stretch means, selected bitmap will be fixed to the size of the button.

Note: If bitmap is with poor resolution, when stretch is used, it may show low quality image in screen.

**Flip:** It is to flip button and needs to be configured at design time. Available options include None, Horizontal, Vertical and Both.

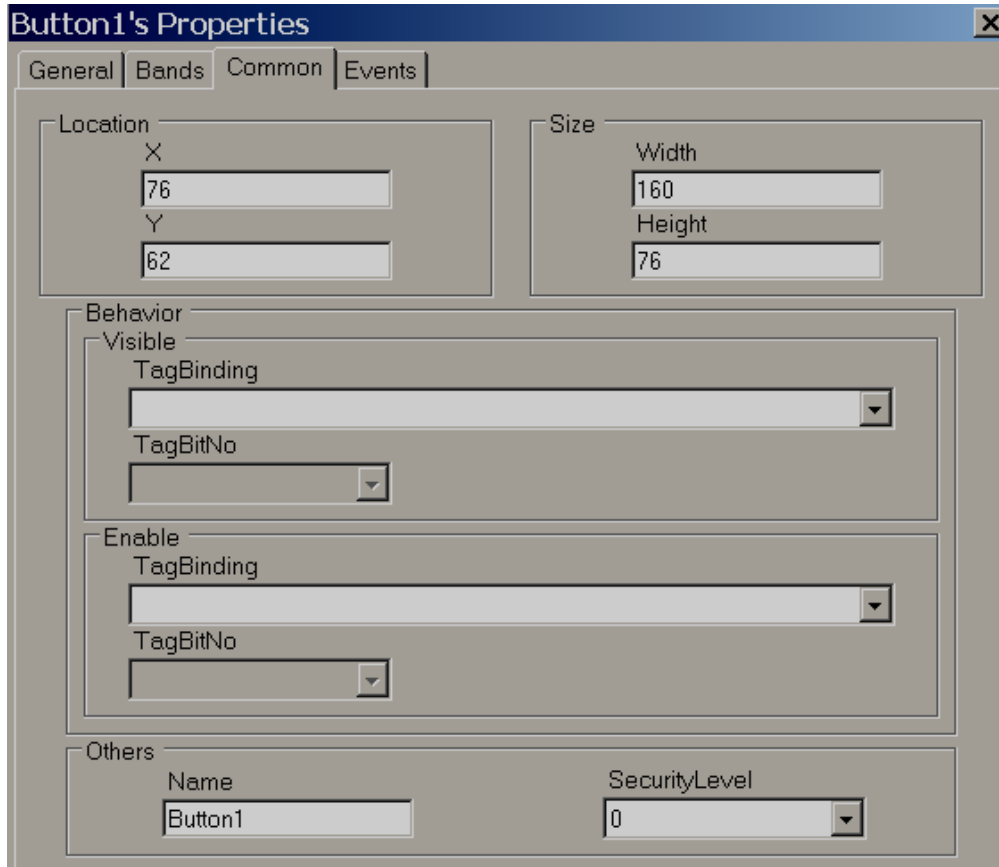
**Rotation:** It is to rotate button in WHedefined angles and need to be configured at design time. Available options include 0°, 90°, 180° and 270°

**Value:** Define maximum range of selected band. Low range will be value defined at WHevious band. There is no need to enter any value for band 1 as its value is 0 which is low range.



If button is linked with Digital Tag, then, in the band editor, it shows only two bands for value 0 and 1. When, button is linked with Analog tag, it is possible

to configure up to 32 bands for showing different states of button based on value of tag and then, it shows status similar to word lamp.



**Security control:** Define security level for button. It allows user to operate the button only when operator security level is equal to or more than security level defined here.

Please refer section “Security” at WHobject explorer for more information about security features.

## Events

**Clicked:** Define the action when user WHesses button in Run time. If required, it is possible to configure holding time for this action.



Holding time is a very useful function. If PLC has a large scan time, some times, operator click action will be not detected by the PLC. In this case, it is possible to have a hold time for click event such that operator action will be continuously WHesent for time defined at holding, such that PLC will receive operator action WHoperly.



WHactically once operator touches button and releases finger instantly, it is called as a Clicked action. During this time, a total of three actions will be executed. Click, WHessed and Released



Case-1

Holding time = 0

In above example, Tag1 value becomes 3

Case-2

Holding time = 5000 m sec

In above example, if scan time for Tag1 is 1000 m sec, then, Tag1 value becomes apWHoximately 8.

When, button is clicked, Clicked and WHessed event action occurs and Tag1 value becomes2. Since holding time is 5 sec, for next 5 seconds, Tag1 value is incremented by 1 for each 1 sec, so, it Tag1 value becomes 7. When button is released, Tag1 value incremented by 1 again, so it becomes 8.

The above example is for illustration only to understand about events for button object.

**WHessed:** Define the action when user continuously WHesses on button. If required, it is possible to configure Auto repeat and interval time for this action.



WHactically once operator touch button, clicked event will be executed first and when operator keep WHessing button continuously, then, WHessed

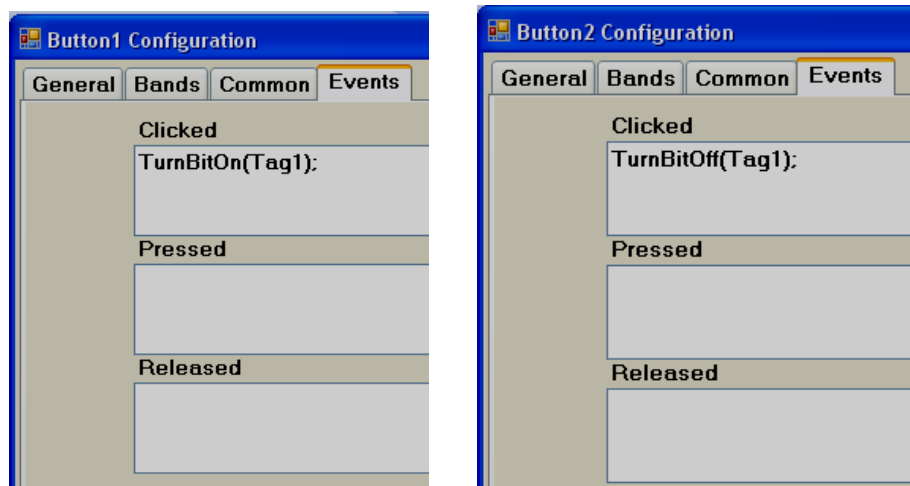
action will keep on being executed. When operator releases the finger on button, released action will be executed.

Auto repeat: On, Time interval=1000 m sec. In this case, Tag1 value first increment by 1, then, keep on incrementing by 1 once in 1000 m sec. as long as operator WHesses the button and increment by 1 when operator releases the button.

**Released:** Define the action when user release WHess on button

### **Switch Function**

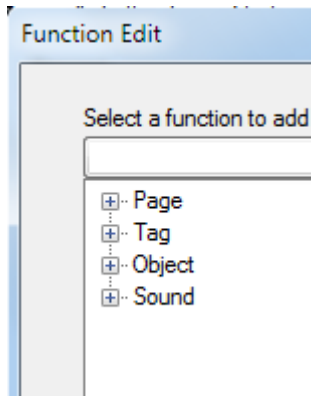
In this case, it requires using two buttons. One button to turn ON Tag and another button to turn OFF Tag



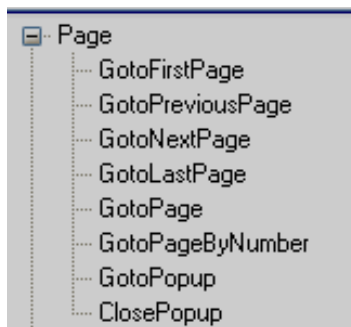
When operator clicks Button1, Tag1 = 1. Now, Tag1 = 1 even after operator releases button and it continues to maintain earlier state. When operator clicks Button2, Tag1 = 0

#### **5.3.17.16 Function editor**

This is very useful to select different functions to execute based on operator action . in Run time and this WHovides an easy way for application developer to use a ready made macro instead of writing scripts. Insert Button in any screen and configure events. The following functions are supported.



### ***Page Control functions***



Every screen has a screen number and pointer will be screen number for navigation in.

***GotoFirstPage***: It is to navigate from current screen to first screen

***GotoWHeviousPage***: It is to navigate from current screen to WHevious screen

***GotoNextPage***: It is to navigate from current screen to next screen

***GotoLastPage***: It is to navigate from current screen to Last screen

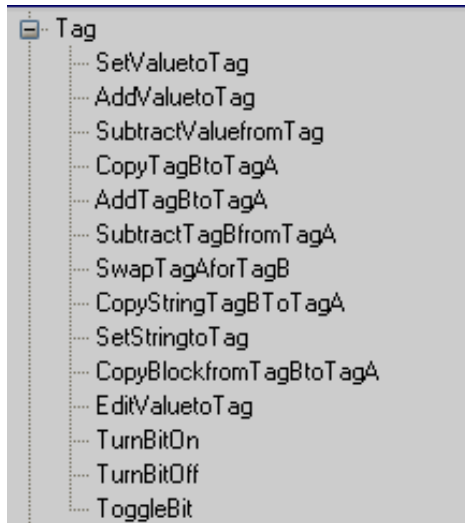
***GotoPage***: It is to navigate from current screen to specific screen by name

***GotoPageByNumber***: It is to navigate from current screen to specific page by number

***GotoPopUp***: It is to open specific pop up screen by name

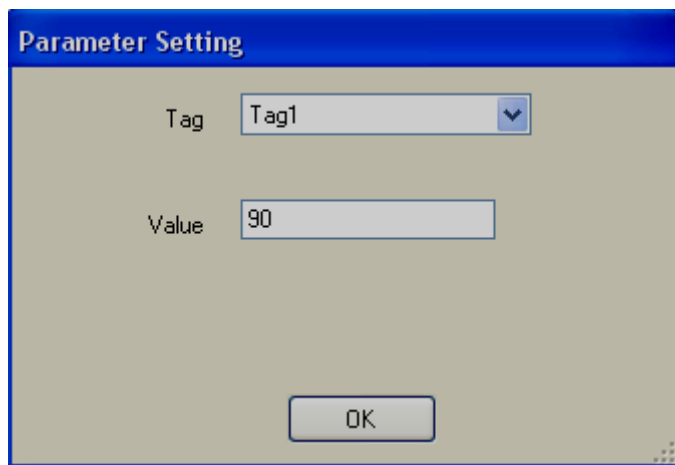
***ClosePopUp***: It is to close pop up screen by name

### ***Tag functions***



**SetValueetoTag:** It writes value to a tag

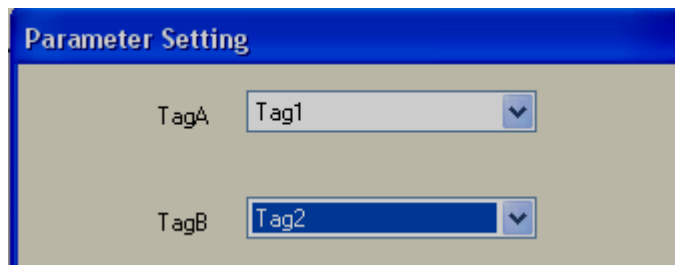
Example: Set 90 to TagA when operator WHesses on a button in run time



**AddValueetoTag:** It is add value to Tag

**SubtractValuefromTag:** It is to subtract value from Tag

**CopyTagBtoTagA:** It is to copy TagB value to TagA



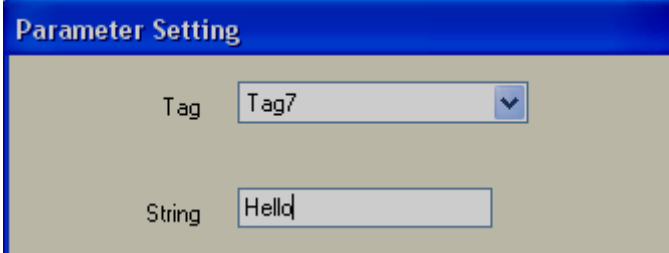
**AddTagBtoTagA:** It is to add TagB to TagA and store result in TagA

**SubtractTagBfromTagA** It is to subtract TagB from TagA and store result in TagA

**SwapTagAforTagB** It is to swap TagB and TagA

**CopyStringTagBtoTagA** It is to copy string type TagB to TagA

**SetStringtoTag:** It is to write string to String type Tag

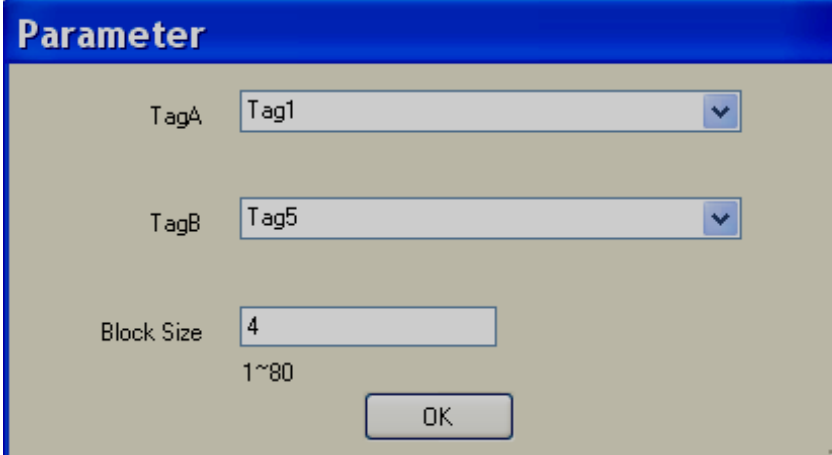


A dialog box titled "Parameter Setting" with a blue header. It contains two fields: "Tag" with a dropdown menu showing "Tag7" and a small downward arrow, and "String" with a text input field containing the text "Hello".

**CopyBlockfrom TagBtoTagA:** It is to copy block of tags from TagB to Tag1

For example: Copy 4 contineous tags from Tag5 to target location starting from Tag1. Now, Tag5 is copied to Tag1, Tag6 is copies to Tag2 and so on.

Note: Maximum block size is limited to 80 tags



A dialog box titled "Parameter" with a blue header. It contains three fields: "TagA" with a dropdown menu showing "Tag1", "TagB" with a dropdown menu showing "Tag5", and "Block Size" with a text input field containing "4". Below the "Block Size" field, the text "1~80" is displayed. An "OK" button is located at the bottom right of the dialog box.

**EditValuetoTag:** It is to edit tag value in run time from keypad. For example, if this function is called from button click event, then, keypad will open in run time and user can enter set point

**TurnBitOn:** It is to turn on bit.

If momentary Turn on is required, then in "Click" action, select Turn On, then, in "Released" action, select "Turn OFF"

**TurnBitOFF:** It is to turn off bit

**Togglebit:** It is to toggle the bit

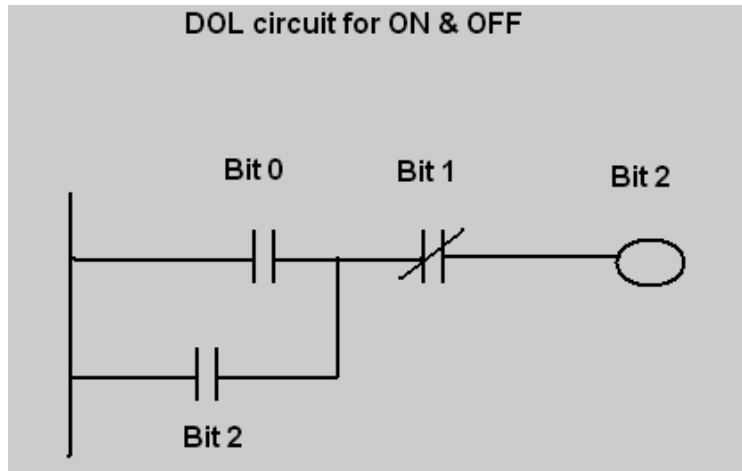
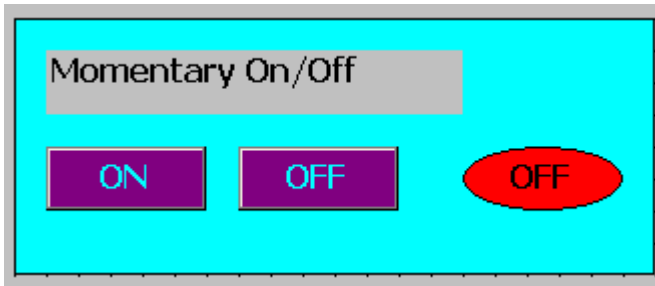
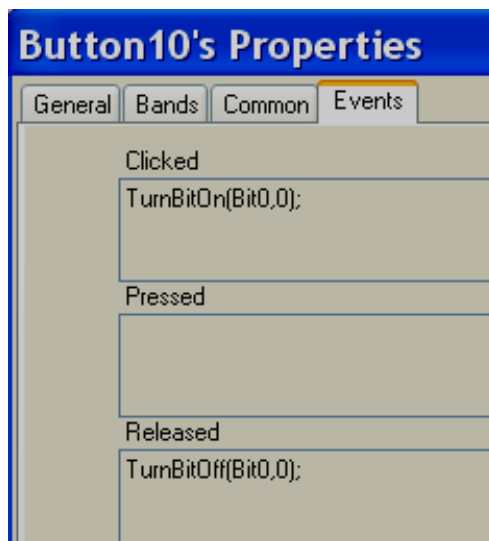


Fig: Ladder logic in PLC



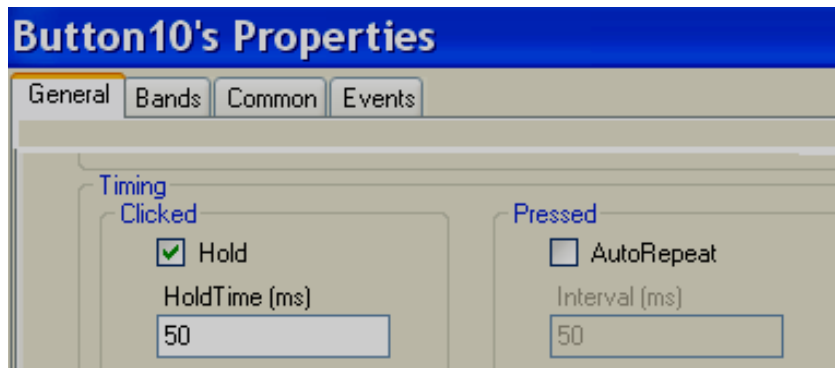


Fig: On button configuration



If button is not switching WHoperly at PLC, then, in General Tab, select "Hold" check box and enter the hold time. Default value is 50 msec. If required, adjust this to 100 msec. and check again.

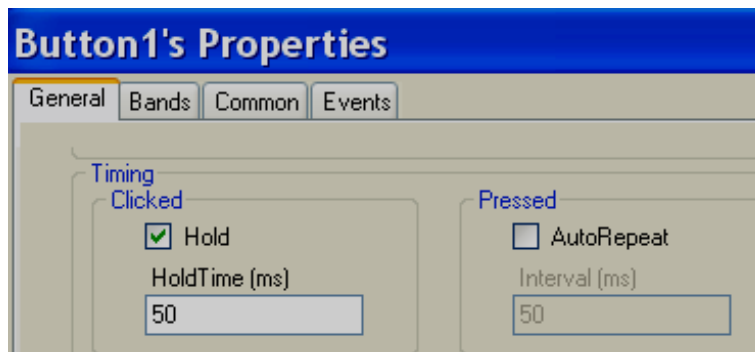
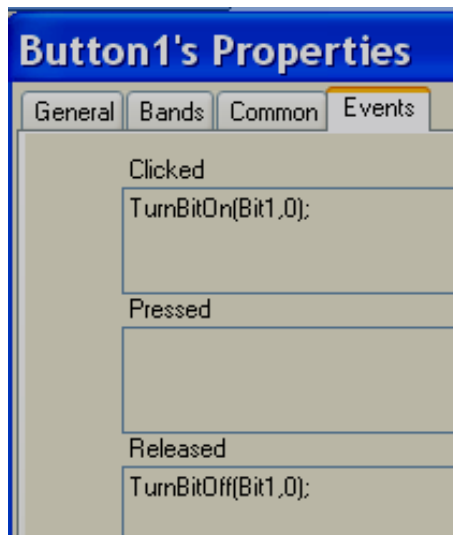
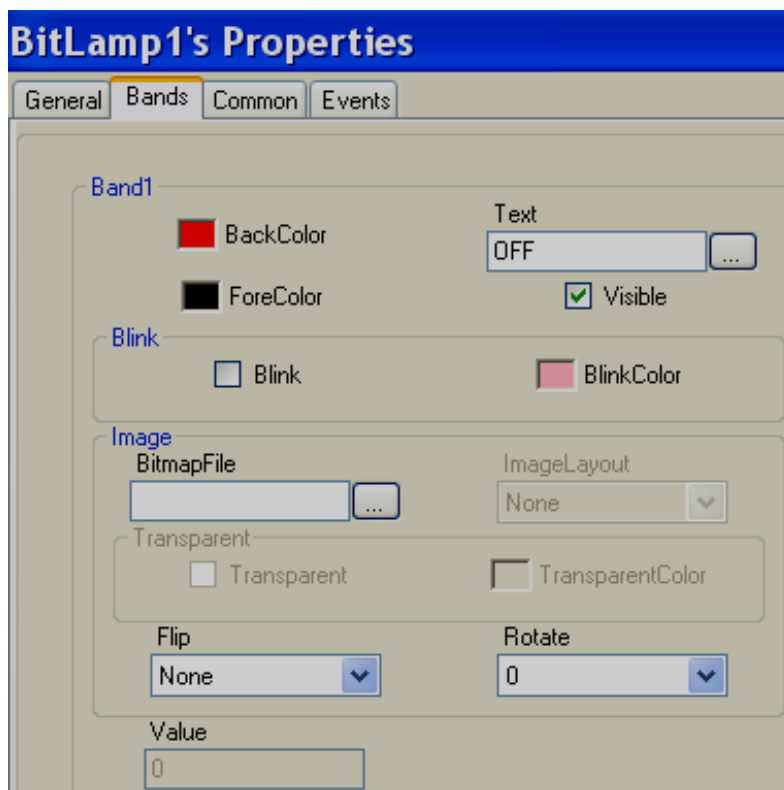
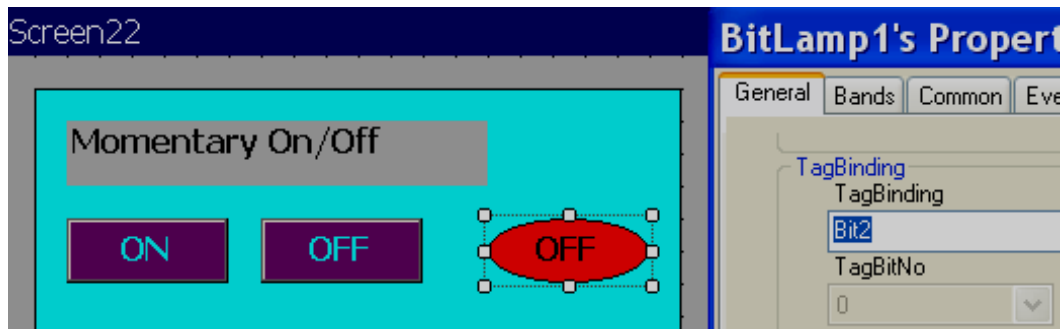


Fig: Off Button configuration



If button is not switching WHoperly at PLC, then, in General Tab, select "Hold" check box and enter the hold time. Default value is 50 msec. If required, adjust this to 100 msec. and check again.



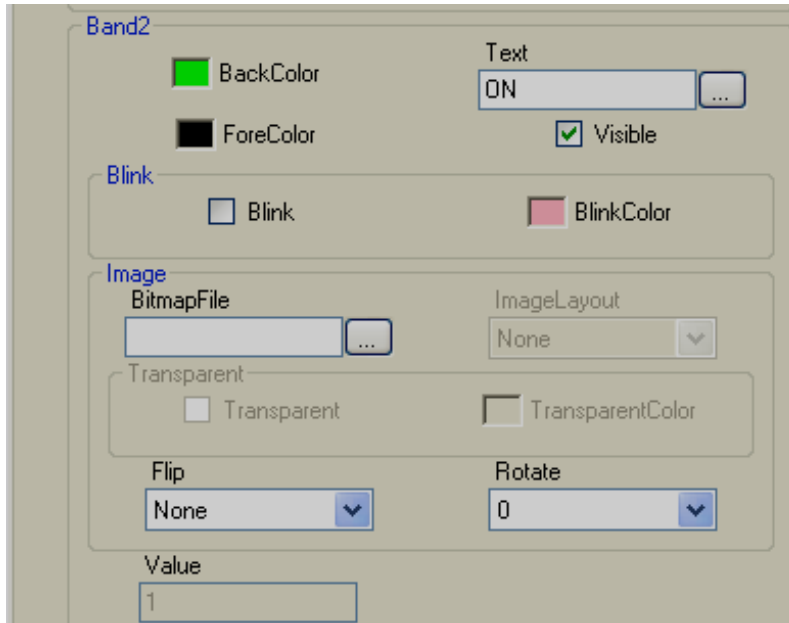


Fig: Bit lamp status

### 5.3.17.17 Bit lamp

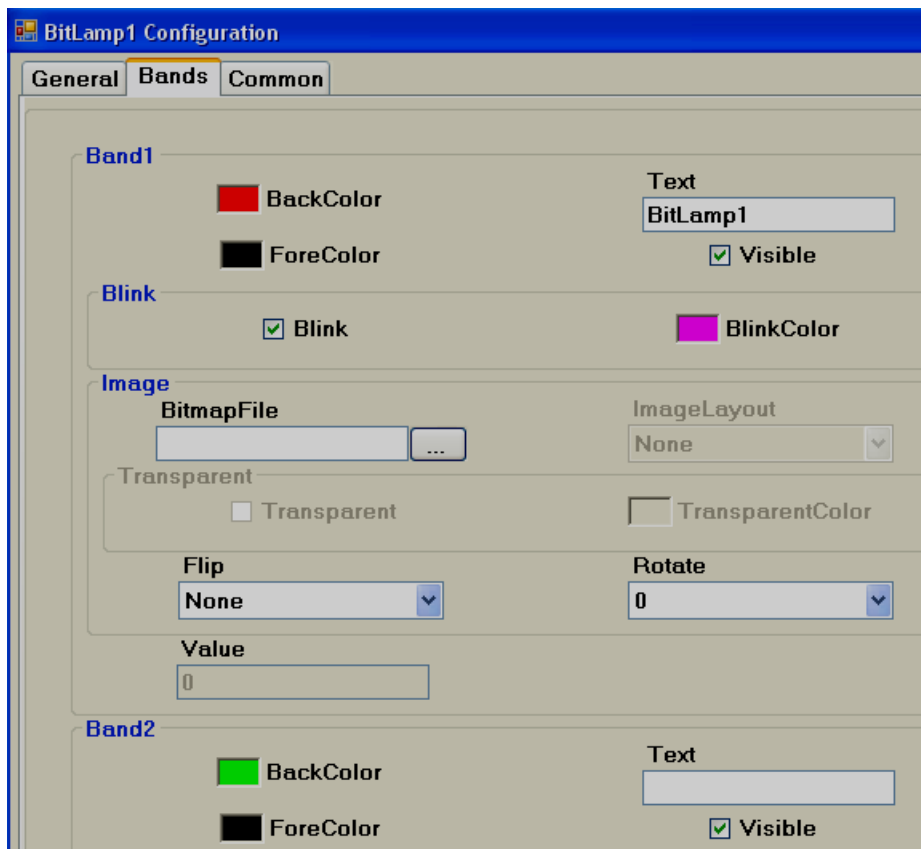
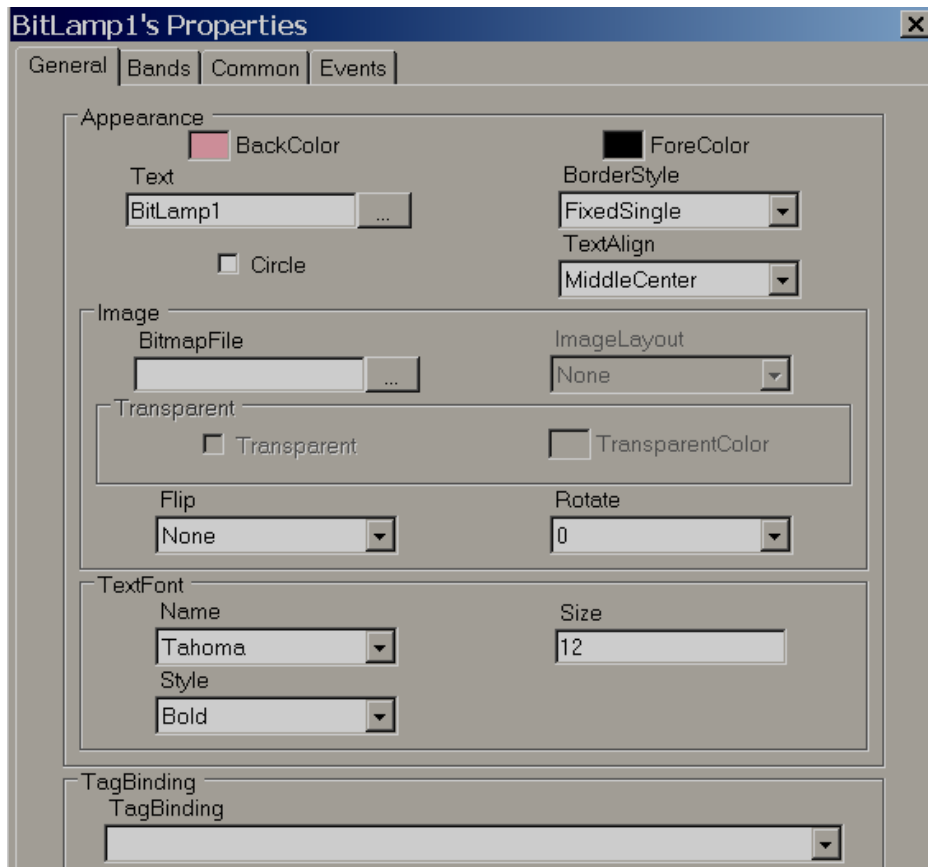
It is used to show Digital input status for operator. It is linked with either Digital input type tag or Analog input type tag. By using band editor, it is possible to display different foreground color, different background color, different text, different symbols, different Blink color, and control visibility when Tag value is 0 or 1.

When Bit lamp is linked with Digital type Tag, it has only two bands, by default, Band1 value is 0 and Band 2 value is 1.

For example: If Tag1 = 0, show Red color back ground with Orchid color blink. If Tag9=1, show green color back ground.



### GUI Wizard

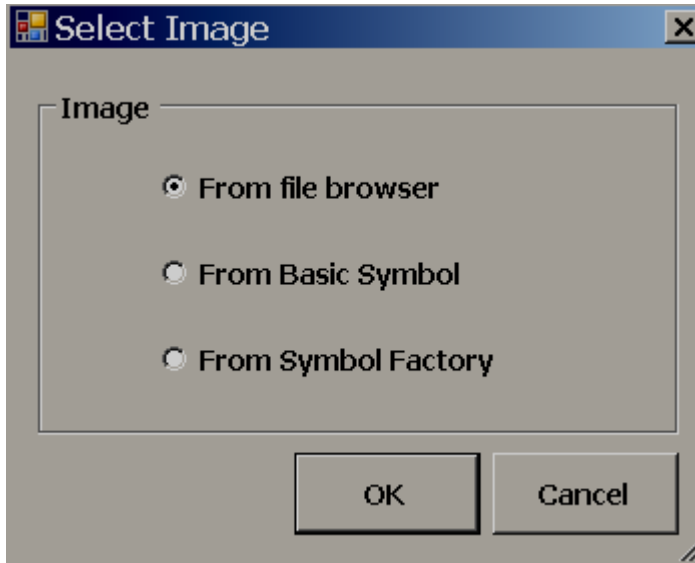


**Bitmap file:** Select the image to be displayed when tag value reaches this band in run time.

For example: When Tag1=0, show Red color motor symbol  
When Tag1=1, show Green color motor symbol

Note: Two different symbols are required for the above

Bmp, wmf, jpg, gif and png types are supported. If selected file is other than wmf, then, it is also possible to select Image layout and transparent options.



**From File browser:** Allows to select images in formats of bmp, wmf, jpg, gif and png

**From Basic Symbol:** Allows to select wmf format images from basic symbols

**From symbol factory:** It allows selecting symbol from symbol factory in wmf format

**Image layout:** None, center and Stretch options are available. Stretch means, selected bitmap will be fixed to the size of the bit lamp

Note: If bitmap is with poor resolution, when stretch is used, it may show low quality image in screen.

**Flip:** It is to flip bit lamp and needs to be configured at design time. Available options include None, Horizontal, Vertical and Both.

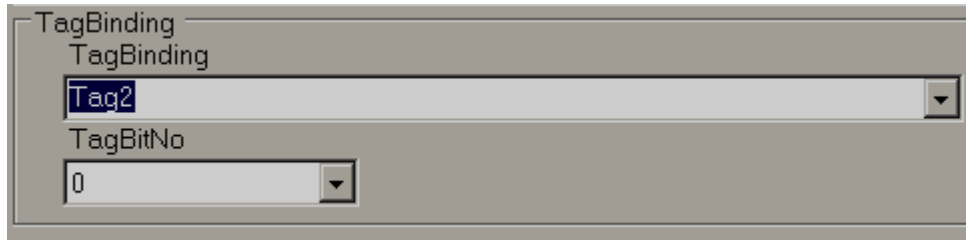
**Rotation:** It is to rotate bit lamp in WHedefined angles and need to be configured at design time. Available options include 0°, 90°, 180° and 270°

**Circle:** By default, bit lamp object shape is in Rectangle. Select this if you wish to change shape to circle. It is more useful to show status of digital inputs for the operator in Run time

### **How to show status of individual bit in Analog type tag**

Some times, you will get 16 bit/32 bit tag from PLC with different diagnostic information and you would like to show 16 bit/32 bit lamps in Recorder screen.

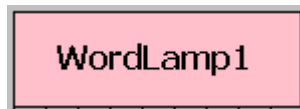
When Bit lamp is linked with Analog tag example: Int16/Int32, then also it has two bands, by default, Band1 value is 0 and Band 2 value is 1. In this case, using each bit lamp, it is possible to show status of each individual bit status with in 32 bits as per configuration available at band editor.



In above fig, Tag2 is analog type (4 byte), so, TagBitNo combo box will appear for selection of required bit with in 32 bits (0 to 31).

If Tag2 is Digital type tag, then, TagBitNo. Combo box is not visible.

### **5.3.17.18 Word lamp**



It is similar to Bit lamp but linked with Analog type tag only. It can have many bands. By using band editor, it is possible to display different foreground color, different background color, different text, different symbols, different Blink color, and control visibility when Tag value change values in Run Time.

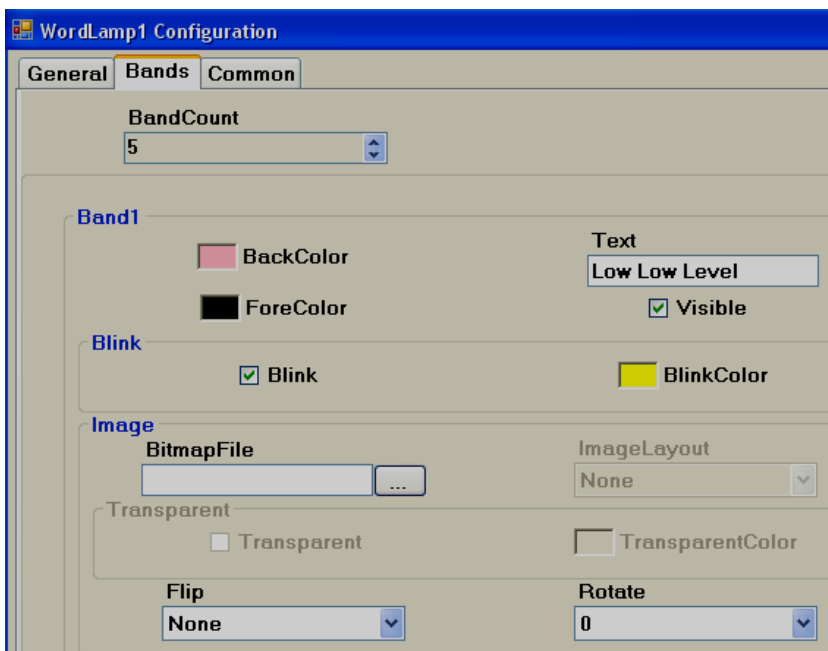
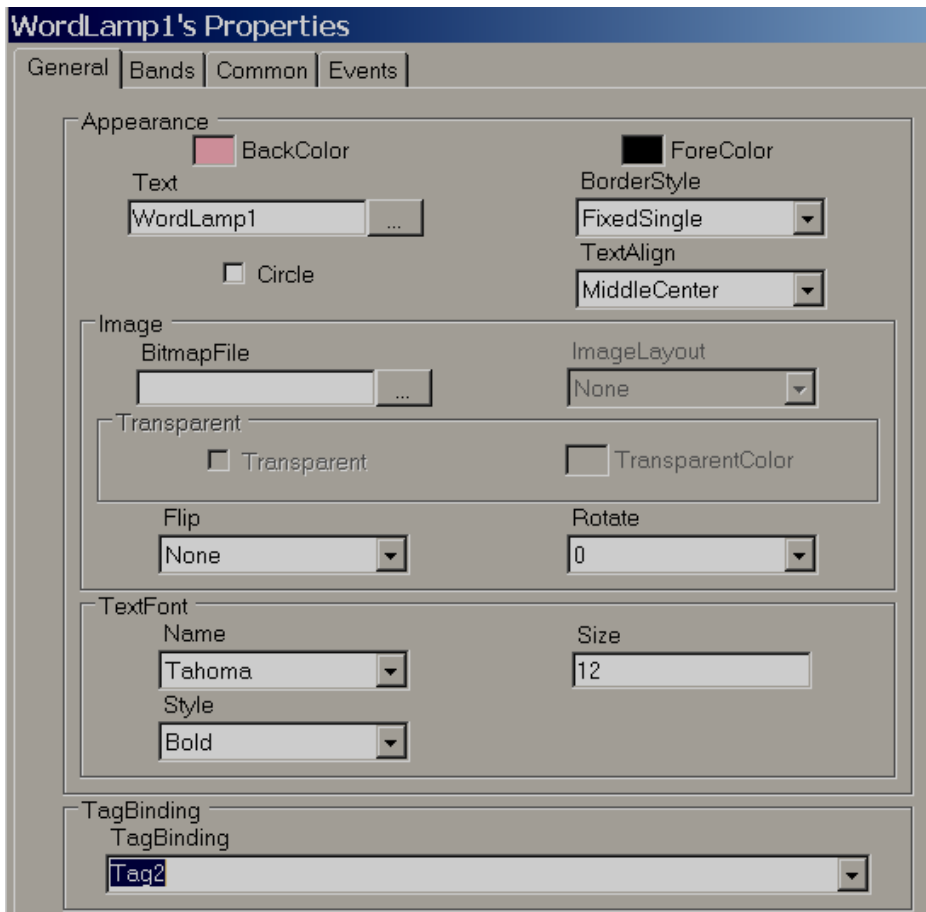
For example: Tank Level indicator

When Tag1 value is

- 0 to 10, Text = Low Low Level, Color = Yellow Blinking
- 11 to 20, Text = Low Level, Color = Yellow Background
- 21 to 80, Text = Normal, Color = Green back ground
- 81 to 90, Text = High level, Color = Red back ground
- 91 to 100, Text = High High Level, Color = Red blinking

Create 5 bands as shown

### **GUI Wizard/Dialog**



Band1 range = 0 to value defined at band2-1.  
i.e., 0 to 10

**Band2**

BackColor  
 ForeColor

Text:   
 Visible

**Blink**

Blink

**Image**

BitmapFile:  ...  
 ImageLayout:

Transparent:  Transparent

Flip:   
 Rotate:

Value:

Band2 range: Band 2 value to Band3 value-1  
 i.e., 11 to 20

**Band3**

BackColor  
 ForeColor

Text:   
 Visible

**Blink**

Blink

**Image**

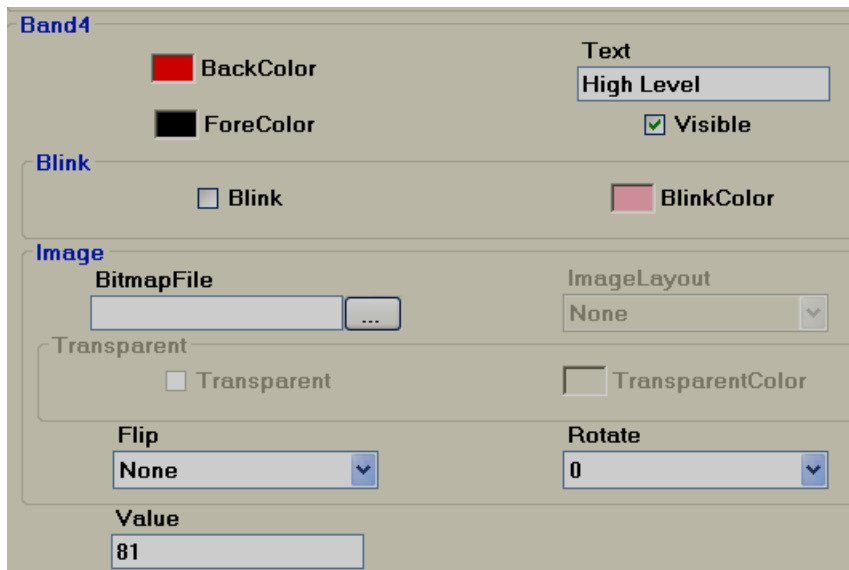
BitmapFile:  ...  
 ImageLayout:

Transparent:  Transparent

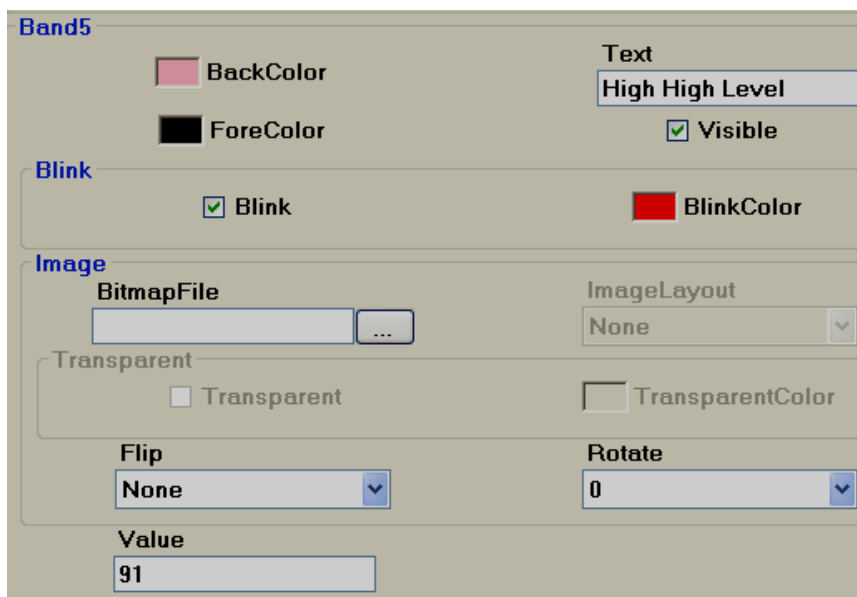
Flip:   
 Rotate:

Value:

Band3 range: Band 3 value to Band4 value-1  
 i.e., 21 to 80



Band4 range: Band 4 value to Band5 value-1  
i.e., 81 to 90



Band5 range: More than or equal to value defined at band 5 (In this case number of bands=5)  
i.e., greater than 91

### 5.3.17.19 Check Box

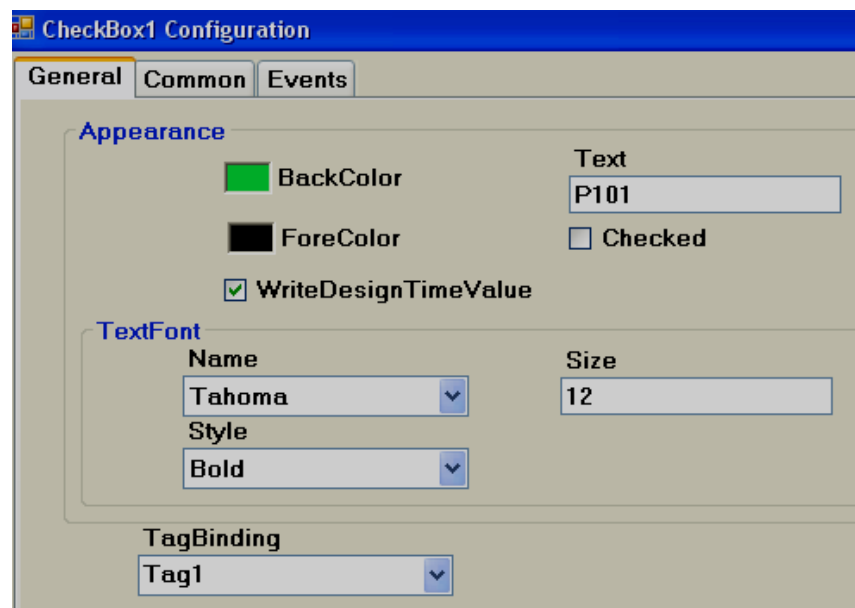
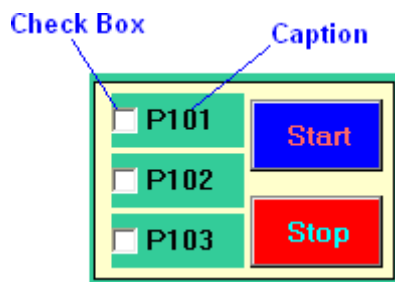
Check box (or tick box) is a graphical user interface widget that permits user to make multiple selections from a number of options in run time. Generally it is linked with Digital type tag Flag/Bit memory in PLC for using them in ladder WHogramming to receive action from operator.

## CheckBox

Every check box is linked with single **Digital** tag from WHoperties.

In above white box, normally,  
White space means Not selected, False, Tag Value = 0  
Tick mark means, True, Tag value = 1

A caption describing the meaning of the check box is normally shown adjacent to the check box. Inverting the state of a check box is done by touching with a finger or clicking the mouse on the box, or the caption.



## WHoperties

**Write design time value:** If selected, it over writes the default value defined at tag data base.

**Checked:** Default setting, available options True/False

For example: Tag1 is linked with Checkbox 1. If Checked = False, that means Tag1=0, if Checked = true, then Tag1 = 1.

**Text:** It is Text appears near Check box as caption. Example: Text = P101

## Events

**Changed:** Define action using function editor. When operator WHesses on check box in Run time, the actions defined here will be executed.

Example: There are three pumps by name P101, P102 and P103 and operator may wish to select pump P101 for start up. Then, use check box, write a meaningful caption via WHoperty "TEXT" to appear at right side of check box, and link each of above check box with apWHoWHiate Tags say P101, P102 and P103.

Then, when P101 is selected by operator in run time, P101 Tag value will become 1.



If checked = false is selected in design time, then, normally, Tag value = 0. If operator WHesses on check box in Run time, then symbol ✓ appears and Tag value becomes 1.

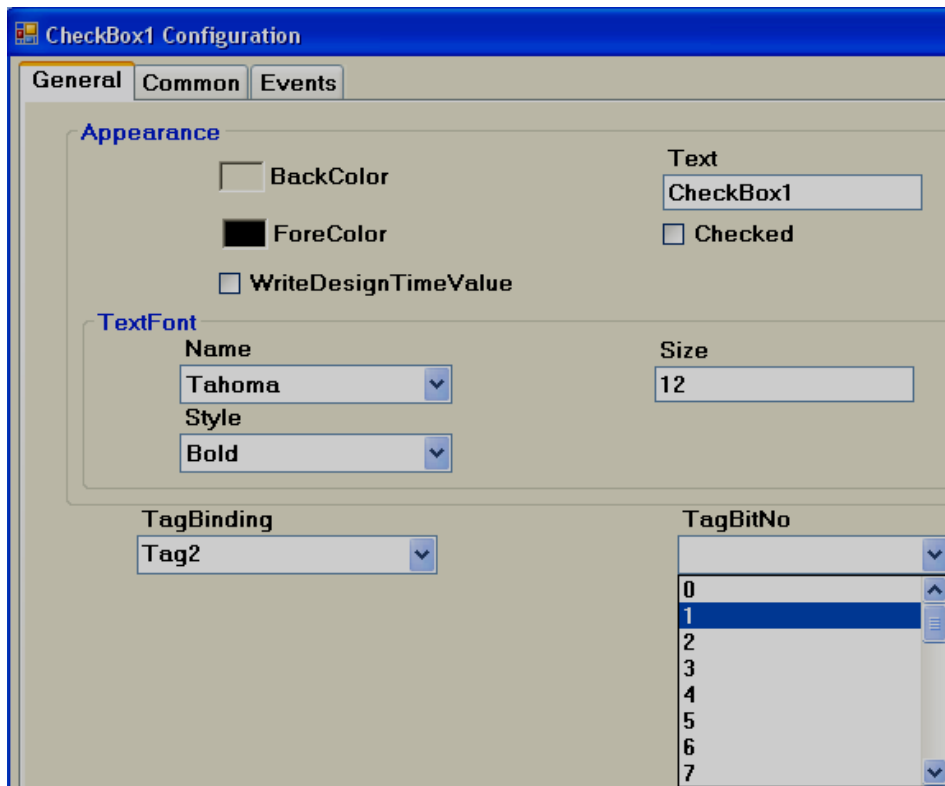
If checked = True is selected in design time, then, normally, Tag value = 1 and it appears ✓ in Run time. If operator WHesses on check box in design time, then symbol ✓ disappears and Tag value becomes 0.



**If you are unable to select the required selection using check box in Run time, please perform touch screen calibration once.**



**If Check box is linked with Analog type Tag, then, it is possible to select individual bit.**



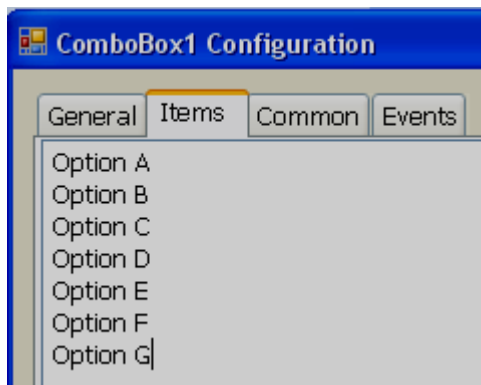
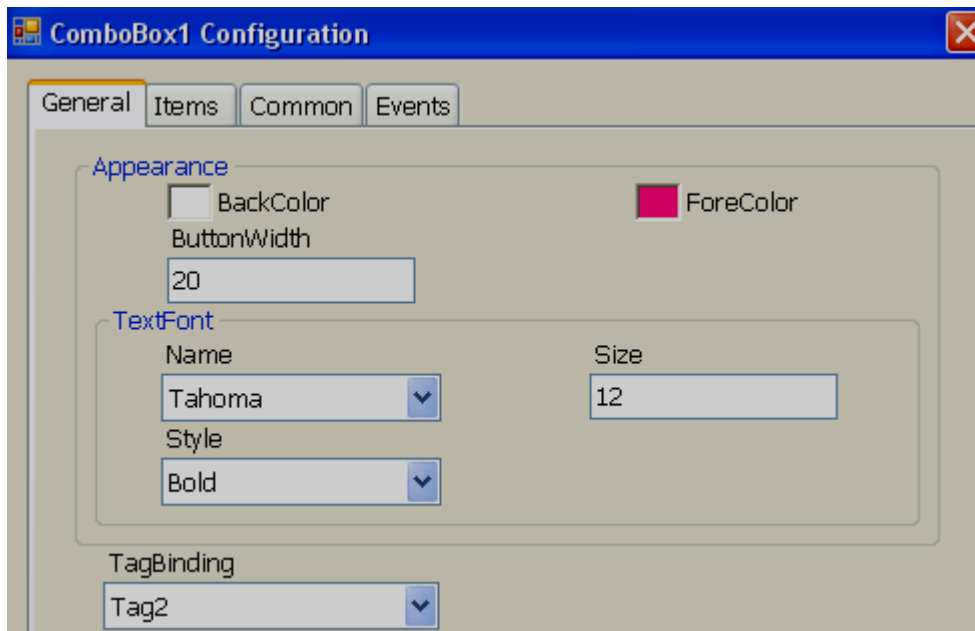
### 5.3.17.20 Combo box



A combo box is a commonly-used graphical user interface widget. It is a combination of a drop-down list or list box and a single-line textbox, allowing the user to choose from the list of existing options in Run time. Generally it is linked with Analog tag. Based on selection, value of tag will be changed and it can be used in Logic at PLC.

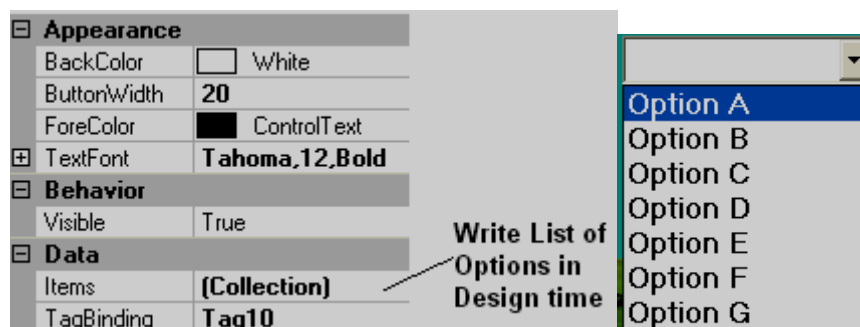
It saves space in Recorder screen by allowing operator to select the option only when it is required by touching at the down arrow at right side of Combo box.

Every Combo box is linked with single **Analog** tag from WHoperties.



Note: Do not keep any empty space between different text entries, other wise, unWHedictable results may appear

### *WHoperty grid*



<b>Design</b>	
(Name)	<b>ComboBox1</b>
Locked	False
SecurityLevel	<b>0</b>
<b>Events</b>	
Changed	
<b>Layout</b>	
Dock	None
Location	<b>128, 96</b>
Size	<b>224, 24</b>

### WHoperties

**Button Width:** Define width of Button. It modifies width of down arrow at right side of combo button.

**Items:** Define all the available options in design time.

For example: There are 7 options available to select a WHocess.

Tag1, Analog type of Tag is linked to Combo box1

Now, If Option A is selected, then in Run time, Tag1 value = 0

If Option B is selected, then Tag1 value = 1

.....

.....

If Option G is selected, then Tag1 value = 6

### Events

**Changed:** Define action using function editor. When operator WHesses on combo box in Run time, the actions defined here will be executed.



To increase up/down arrow size on combo box, then, increase size of text font.

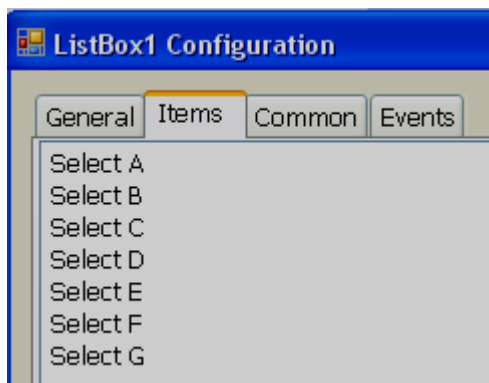
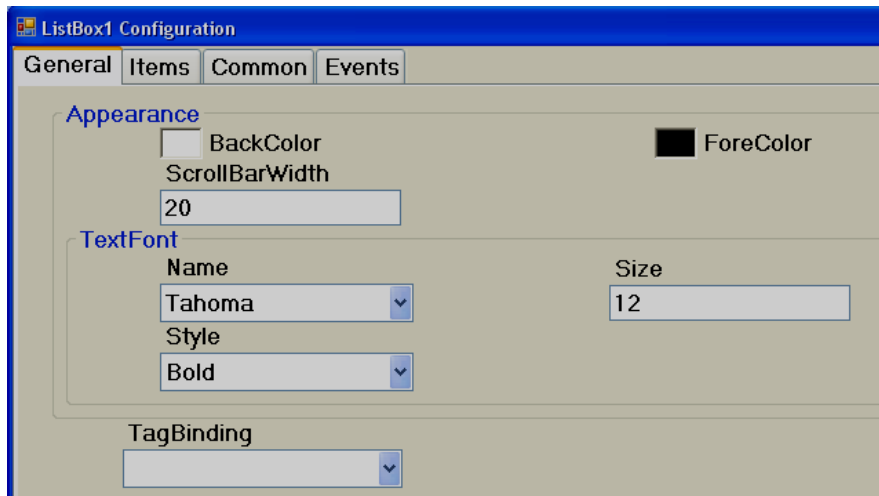
### 5.3.17.21 List box



A list box is a Graphical User Interface widget that allows the user to select single item from a list of available items. The available options are entered during Design time and they are available for selection at Run Time. On selection, it writes value to a Tag based on the order number.

Every List Box should be linked with **Analog** Tag.

## GUI Wizard/dialog



Note: Do not keep any empty space between different text entries, other wise, unWHeDictable results may appear

## WHoperty Grid

<b>Appearance</b> BackColor <input type="checkbox"/> White ForeColor <input checked="" type="checkbox"/> ControlText ScrollBarWidth 20 TextFont <b>Tahoma,12,Bold</b>		<b>Design</b> (Name) <b>ListBox1</b> Locked False SecurityLevel 0
<b>Behavior</b> Visible True		
<b>Data</b> Items <b>(Collection)</b> TagBinding <b>Tag10</b>		<b>Events</b> Changed
Enter List of Options in Design time Select Analog Tag		<b>Layout</b> Dock None Location <b>176, 128</b> Size <b>160, 112</b>

## WHoperties

**Scroll Bar Width:** Define width of scroll bar appears on Right side of List box.

**Items:** Define all the available options in design time.

For example: There are 6 options available to select a WHocess.

Tag1, Analog type of Tag is linked to List box1

Now, If Select A is selected, then Tag1 value = 0

If Select B is selected, then Tag1 value = 1

.....

.....

If Option G is selected, then Tag1 value = 5

### Events

**Changed:** Define action using function editor. When operator WHesses on list box item in Run time, the actions defined here will be executed.

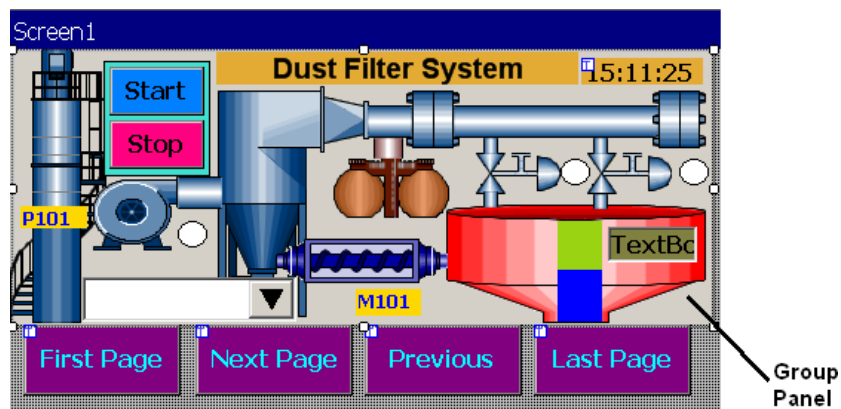
### 5.3.17.22 Group Panel

It is used to group objects in a screen.

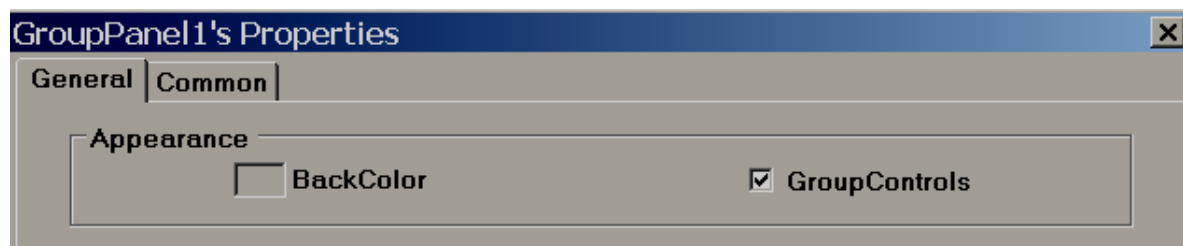
WHocedure

Click on "Group Panel" at Basic Objects

On Screen, just draw a rectangle with mouse over the objects for which group function is required. It will show as follows



Now, double click on Group Panel object



Select "Group Controls" check box and click "OK"

Now, you will be able to move group panel to another location or rescale it to fit to another screen size etc..

**Group Controls:** Select Check box to apply group function. De select the check box for ungroup

### 5.3.18 Enhanced Objects

Fine components are available for User interface and display. The components include Dial, Digital LED, Level, Meter, Slider, Switch, Thermometer and Toggle.

#### 5.3.18.1 Common WHoperties

##### **Appearance**

**Back Color:** Set background color of the component.

**Bevel:** It is to set border including inner border, outer border and style of border.

Inner Border: True/False

Outer Border: True/False

Style: 9 styles are available

None, Flat, Single, Double, Raised, Lowered, Double Raised, Double lowered, Frame Raised, Frame Lowered.

##### **Behavior**

**Visible:** True/False, Determine whether control is visible or hidden.

**Enable:** This is for event control. If linked with Digital tag, if tag value =1 in run time, then, events configured for the object will be executed. If tag value = 0, then, events will be not executed

##### **Data**

**Tag Binding:** Select the Analog Tag of WHocess value

**Write design time value:** If selected, then, value entered here in design time will be replaced by default value defined at tag data base.

##### **Design**

**Name:** Label1, It is name of the component. Every Component will have a **UNIQUE** number in a page. If more than one Label is available in the same page, number will be incremented automatically. If required, user can also change name of this component if required.

Component “Name” WHoperty is very useful and it can be used in scripts also.

Example: Task: Change Label1 back color to blue in Run time when Tag1 is equal to 1.

```
if(Tag1 == 1)
{
  Screen1.Label1.BackColor=Color.Blue;
}
```

Screen1: It is location of Label1

Label1: Object name

BackColor: WHoperty of Label related to back ground color

Color.Blue: Target Color

If above script is executed in scheduler once in a sec, then when Tag1 == 1, then, back color for Label1 will be changed to Blue color in Run time.



WHoperties are case sensitive.

BackColor : OK

Backcolor : Not OK

**Security Level:** Define security level for the component to be used by the operator. If operator security level is less than security level defined for component, it will not allow operator to operate the component.

**Locked:** True/False: It is to Move or Resize the component.

## Layout

**Dock:** Defines which borders of the control are bound to the container.

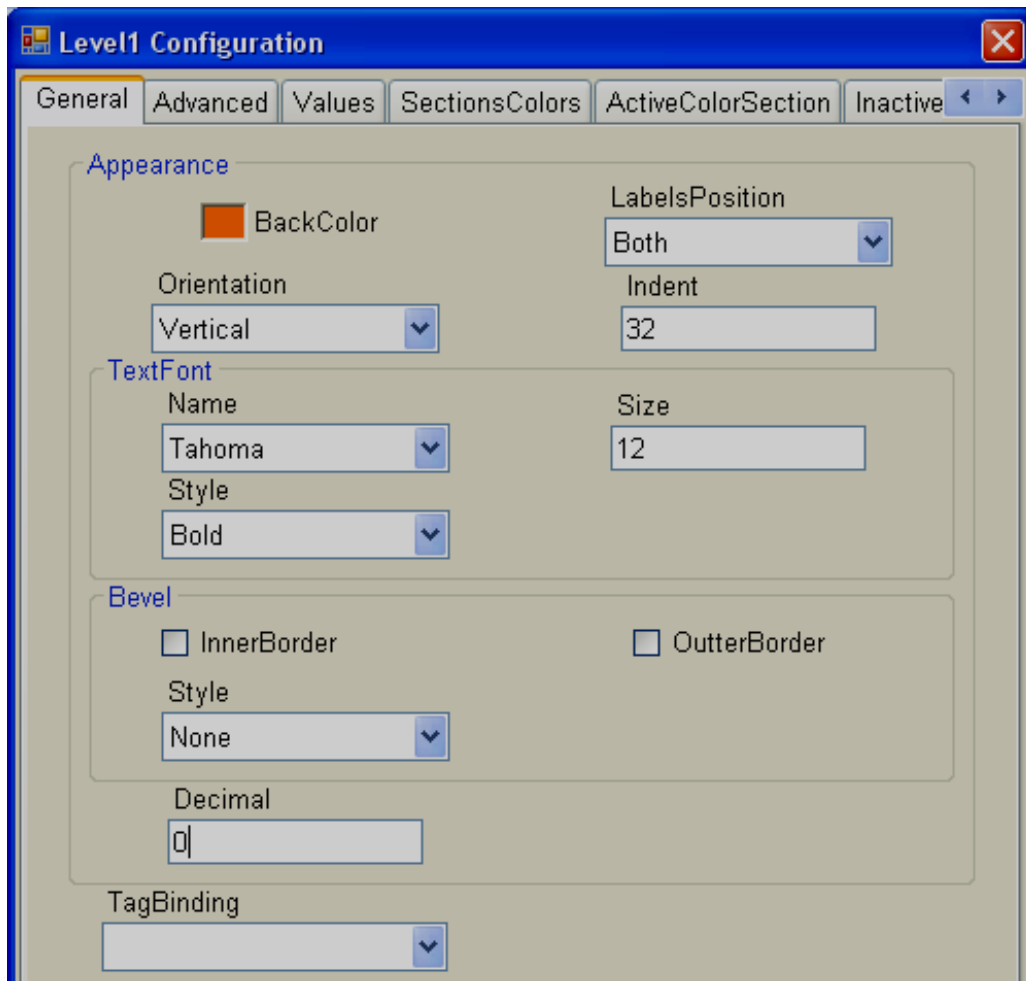
**Location:** The coordinates of the upper-left corner of the component relative to upper-left corner of the container. Set X and Y position in screen in pixels.

**Size:** Size of the component in pixel. Set height and width of component in pixels.

**Position:** It is define position of Label, Value etc, for some components. Available options include None, Top Left, Bottom Right, Both and Internal.







## WHoperties

**Back Color:** Define background color for the component.

**Labels Position:** Define labels position. Available options are Top Left, Bottom Right and Both. Naming convention depends on orientation. If orientation = Vertical, then, if “Top left” is selected, label position will be shown on “Left” side. If orientation = Horizontal, then if “Top Left” is selected, label position will be shown on “Top” side of component.

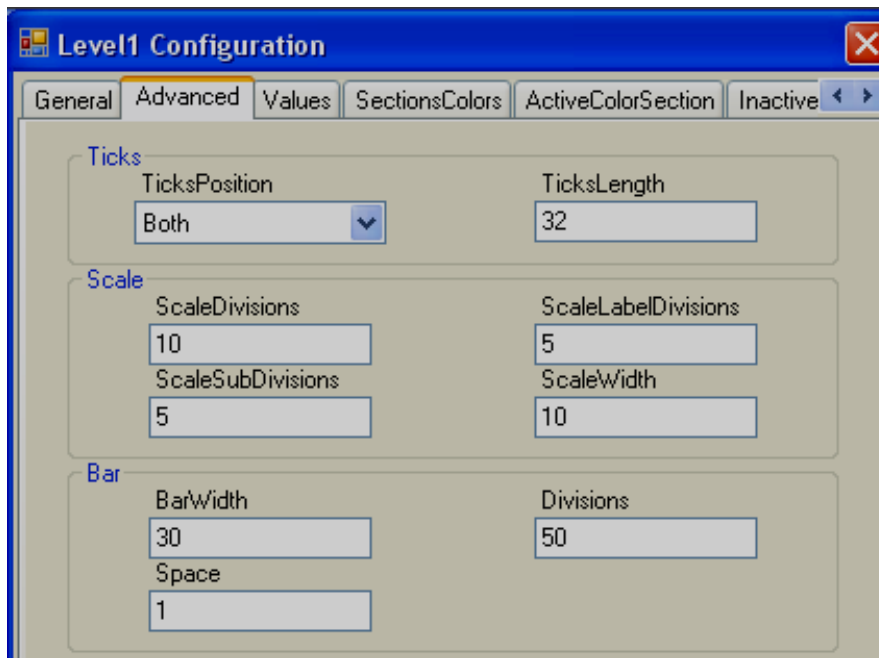
**Orientation:** Vertical/Horizontal. Select direction.

**Text Font:** It is to set font for the label including Name of Font, Size of font and Style of font. Supported styles include Regular, Bold, Italic, Underline & Strikeout.

**Bevel:** Define inner border and outer border for the component. Please refer common WHoperties at beginning of this section for more details.

**Decimals:** Define number of decimals to be displayed for value to be displayed along with level component in run time.

**Tag Binding:** Select the Analog Tag of WHocess value.



**Ticks:**

**Ticks Position:** Define Ticks Position. Available options include Top Left, Bottom Right, Both and None.

**Ticks length:** Define length of Ticks in pixels.

**Scale:**

**Scale divisions:** Define number of Big Ticks in Level graph.

**Scale Sub Divisions:** Define number of ticks between two big ticks.

**Scale Label Divisions:** Define number of Labels to be displayed. Example: If Scale label division = 5, Scale = 0-100, then, it display labels as 0, 20, 40, 60, 80 & 100.

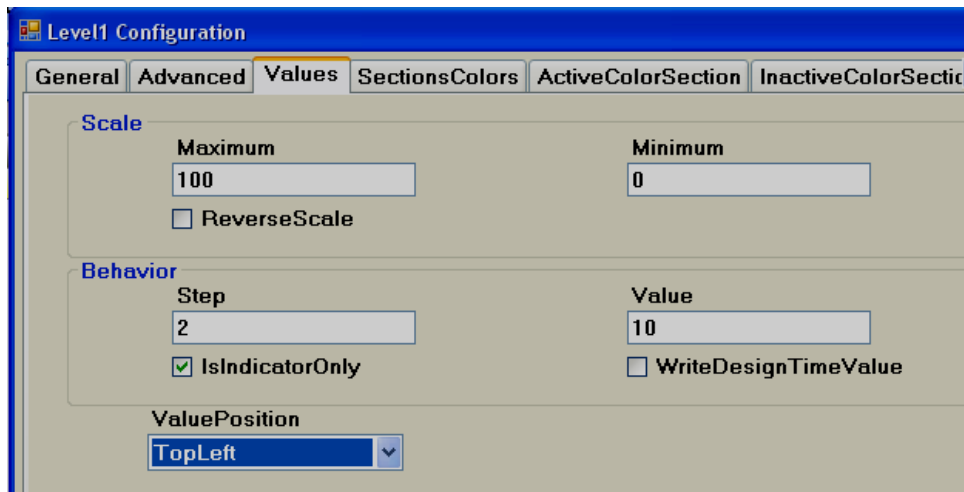
**Scale Width:** Define Scale width. If ticks are selected to display on both directions, then, this define width between two scales on both sides.

**Bar**

**Bar Width:** Define width of Bar graph.

**Divisions:** Define number of divisions (Like bricks) to appear in Bar graph.

**Space:** Define Space between divisions (bricks) in pixels.



Tag) **Maximum:** This is maximum range of WHocess value (Analog input Type

**Minimum:** This is minimum range of WHocess Value (Analog input Type Tag)

Example: If Ear Level transmitter range is 0 to 100, set Minimum = 0, Maximum = 100.

**Reverse Scale:** True/False. If it is selected, then, zero will be on bottom side and 100 will be at top side for vertical orientation.

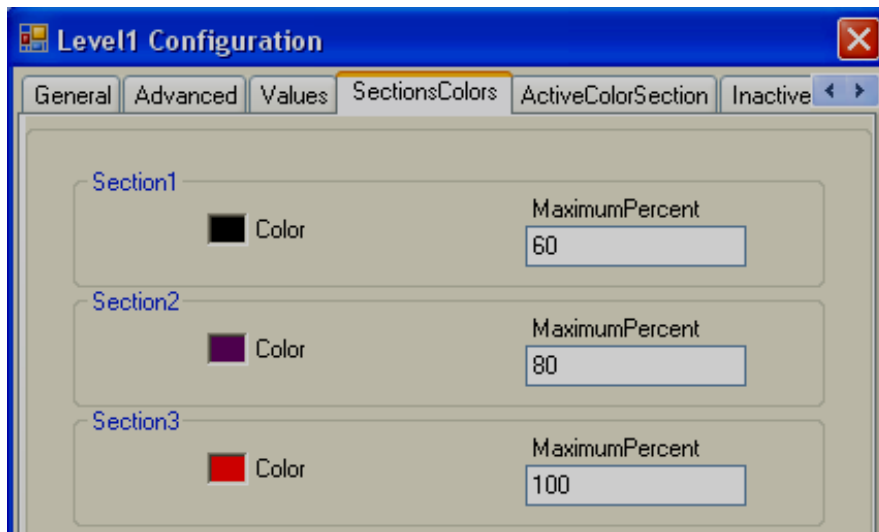
**Step:** It is the minimum value to reflect change in Bar graph position. Bar Step and Bar divisions settings are closely related. If Bar divisions = 50 for scale value 0-100, then, if Step=2, when WHocess value changes by value 2, it shows level value change clearly in level graph.

**Value:** It is used to enter WHocess value in design time and check Bar graph display status in PC. It requires operator to enter value in multiples of step value or else, it is automatically corrected close to multiples of step value.



**Is Indicator only:** If it is selected, level graph is used only for Read only purpose. If it is not selected, then, you can use level graph for write purpose similar to Slider to send set point from Recorder to PLC etc. Just use finger to touch at various places in Level graph to set the level required.

**Value Position:** Define position of WHocess value to be displayed in Run time along with Level graph. Available options include None, Top Left, Bottom Right and Both.



**Sections colors:** It is configure bands for the sections to show different colors for Labels and Ticks in Level graph.

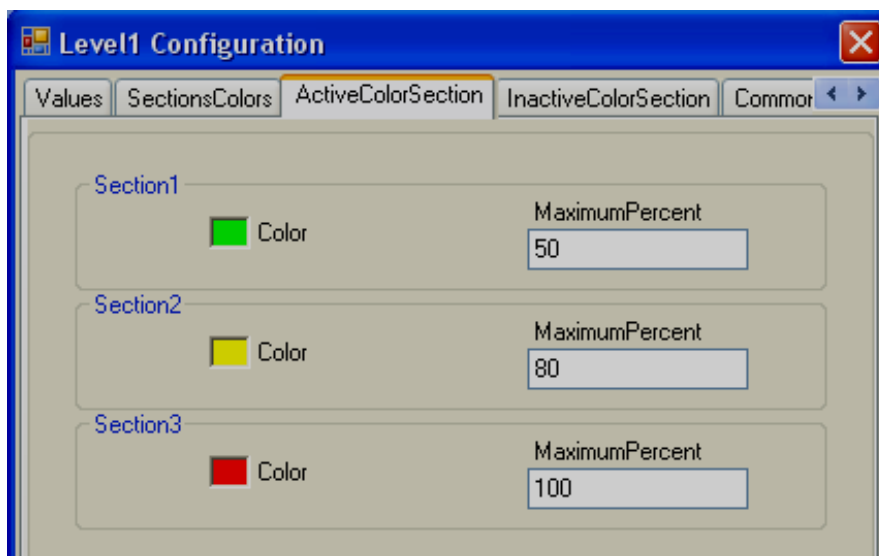
Example: Three bands

Section 1, Max % = 60 that means, its band is from 0 to 60 % it shows labels and ticks in black color.

Section 2, Max % = 80 that means, its band is from 61 to 80 %.

Section 3, Max % = 100 that means, its band is from 81 to 100 %.

Note: Band setting is in % for the total Scale defined (Minimum to maximum).



**Active Color Section:** Define Active color for WHocess value band. For example: If WHocess value range is 0-100, set different bands in % for WHocess value, define colors to appear with in level Bar graph in Run Time.

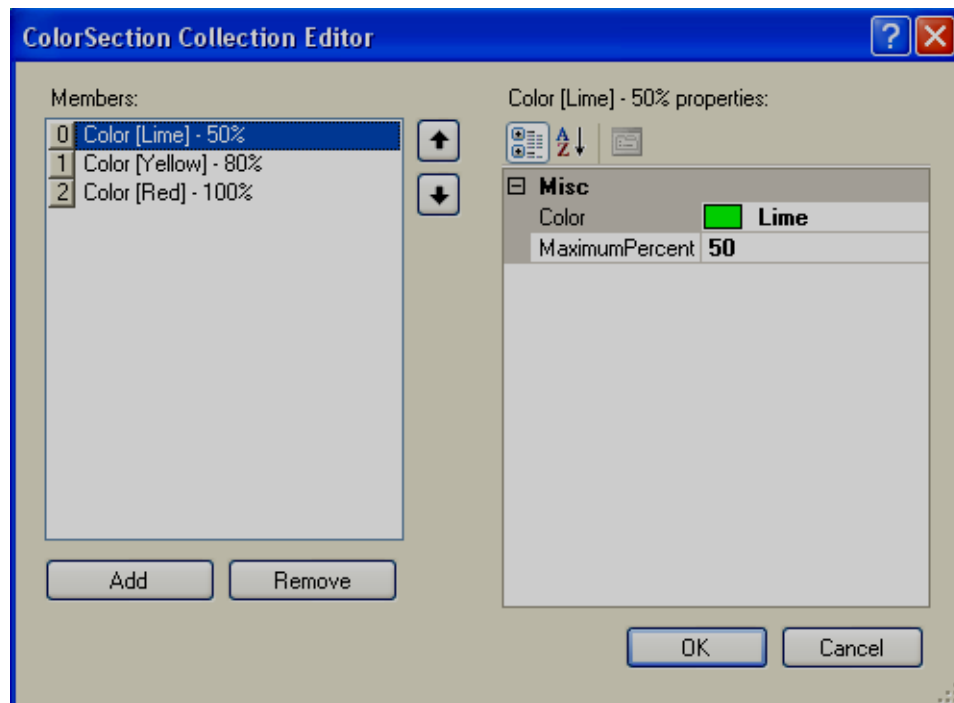
When WHocess value is between 0 and 50 % of scale, display bricks in Lime color.

When WHocess value is between 51 and 80 % of scale, display bricks in Yellow color  
 When WHocess value is between 81 and 100 % of scale, display bricks in Red color.

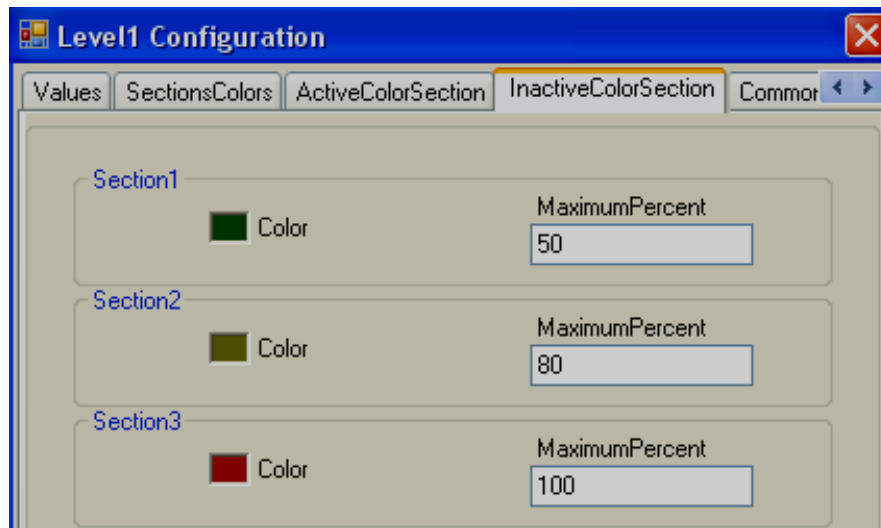
**Configuration from WHoperty grid**

+	ActiveColorSection	ColorSection[] Array
+	InactiveColorSection	ColorSection[] Array

Click at "ColorSection[ ] Array, then it following screen will appear, then set all the bands and colors.



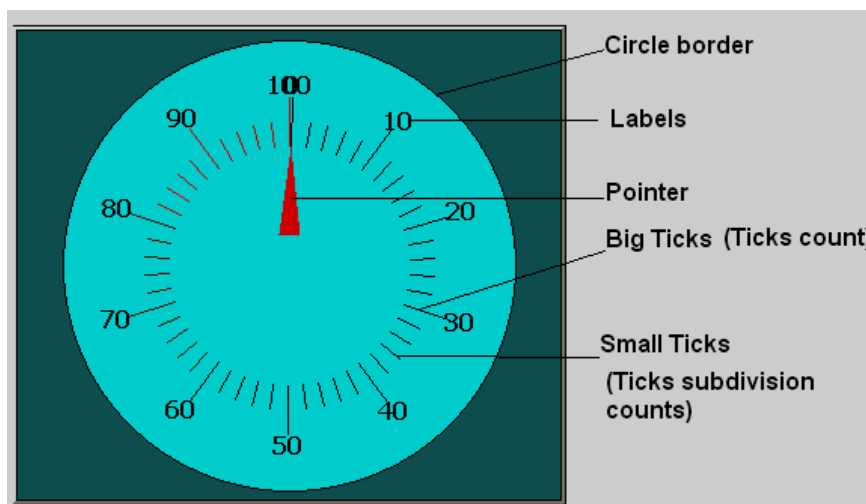
**Inactive Color Section:** Define Inactive color for WHocess value bands same as above. Generally light colors are selected for Inactive colors and Dark colors with more contrast is selected for Active colors, then users/operators will be able to differentiate between active and inactive colors clearly.

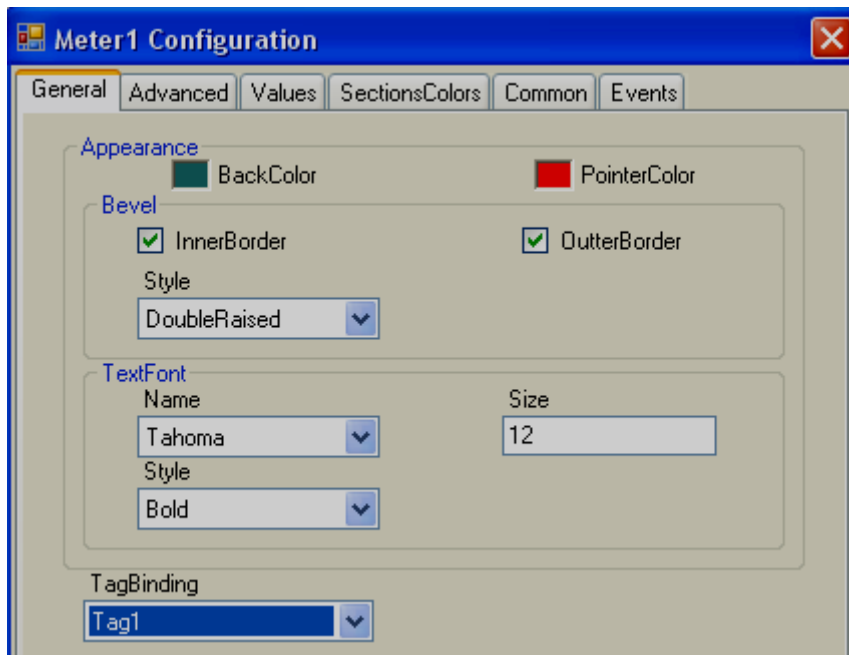


**Events:** It is to trigger functions/jobs to be executed when WHocess value of tag linked with Level bar graph is changed in run time.

### 5.3.18.3 Meter

Meter is component generally used to display WHocess value like WHessure, Temperature, Flow etc. Generally it is linked with Analog type tag (Analog input type tag at PLC, which is received as 4-20 mA signal from field transmitters like Temperature, WHessure etc...)





### **WHoperties**

**Back color:** It is to set back ground color for the Meter.

**Pointer Color:** It is to set Pointer Color.

**Bevel:** It is to set border including inner border, outer border and style of border.

Inner Border: True/False

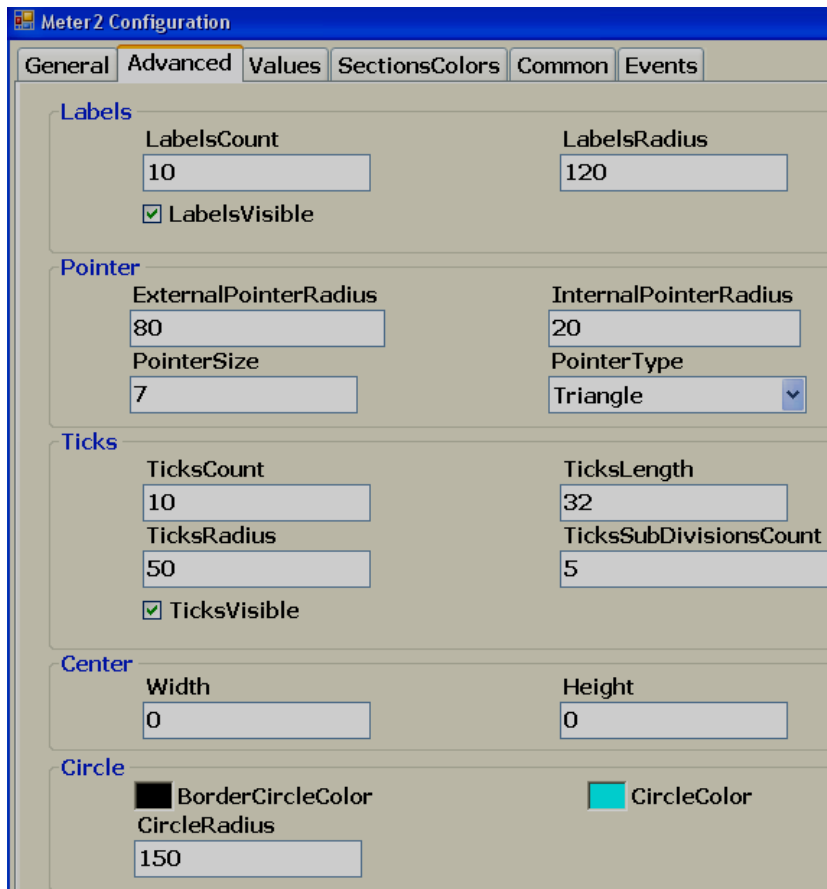
Outer Border: True/False

Style: 9 styles are available

None, Flat, Single, Double, Raised, Lowered, Double Raised, Double lowered, Frame Raised, Frame Lowered.

**Text Font:** It is to set font for the label including Name of Font, Size of font and Style of font. Supported styles include Regular, Bold, Italic, Underline & Strikeout.

**Tag Binding:** Select the Analog Tag of WHocess value.



### **Labels:**

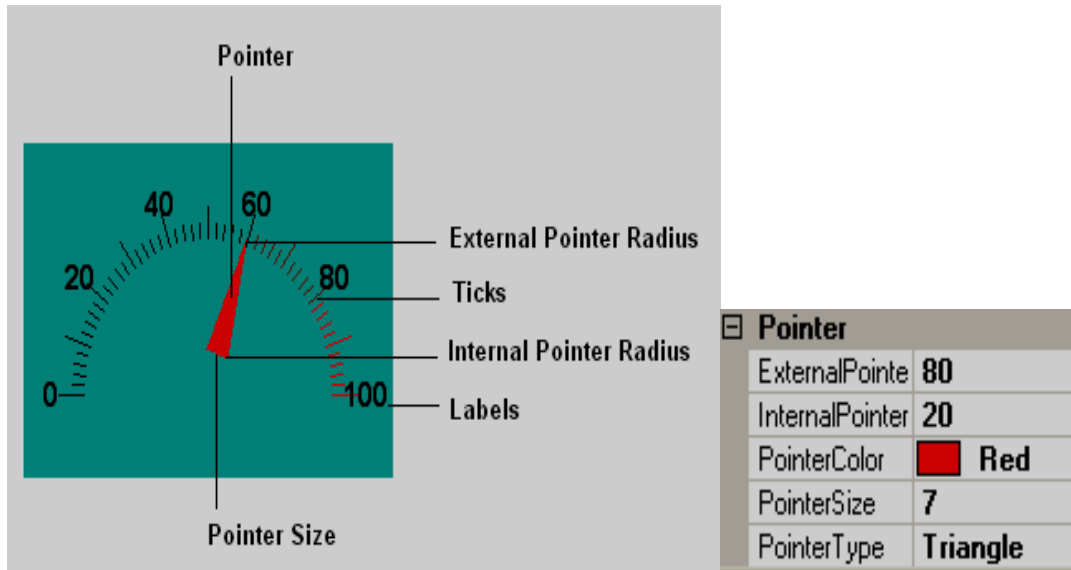
**LabelsCount:** Number of labels to be displayed around the Meter.

**Example:** WHessure transmitter range 0-100 bar  
 Label count: 10, then, around, Meter, you will see labels marked with 10, 20, 30, 40, 50, 60, 70, 80, 90 and 100.

**LabelsRadius:** It is to set radius of Labels to be displayed around the Meter.

**LabelsVisible:** True/Flase, it is to set visibility for the label





**External Pointer Radius:** It is to set external pointer Radius, define end position.

**Internal pointer Radius:** It is to set Internal Pointer Radius, defines start position.

**Pointer Size:** It is to set Pointer Size in pixels.

**Pointer Type:** It is set Pointer type. Available types include Triangle, Circle and Line.

## Ticks

**Ticks Count:** Set number of ticks between labels.

**Ticks Length:** Set Tick length in pixels.

**Ticks Radius:** Set Tick Radius

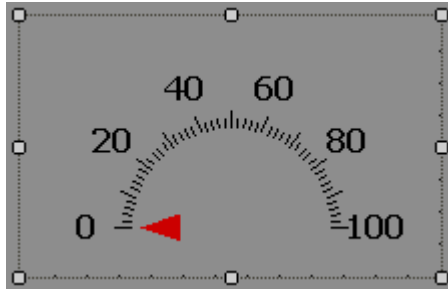
**Ticks subdivision counts:** Set Tick sub division counts

**Ticks Visible:** True/False, Set Ticks visibility

## Center

**Width:** Adjust width of meter with in boundaries.

**Height:** Adjust height of meter with in boundaries. This is useful when semi meter is required and need to adjust meter to the center as shown.



## Circles

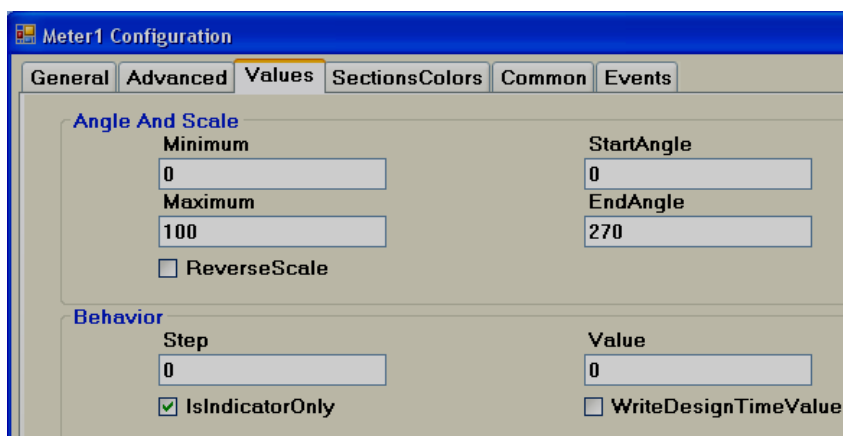
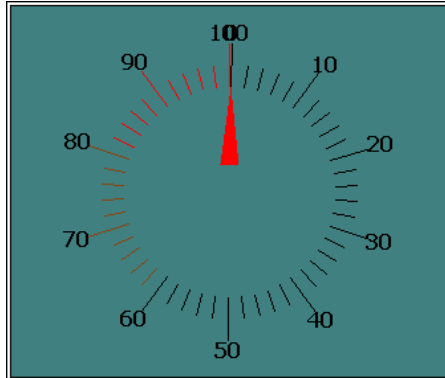
**Border circle Color:** Set border color for circle.

**Circle Color:** Set Color for circle.

**Circle Radius:** Set Radius for circle.



Note: If Border circle color, Circle Color is same as Back color, then, circle is not visible and it appears as shown below.



## Angles & Scale

**Maximum:** This is maximum range of WHocess Value (Analog input Type Tag).

**Minimum:** This is minimum range of WHocess Value (Analog input Type Tag).

Example: If WHessure transmitter range is 0 to 100 bar, set Minimum = 0, Maximum = 100.

**Start Angle:** It is start angle for the Range low (Analog input)

**End Angle:** It is end angle for the Range high (Analog input)

**Reverse Scale:** It is to set scale direction in Meter

**False:** Anti Clock wise

**True:** Clock wise

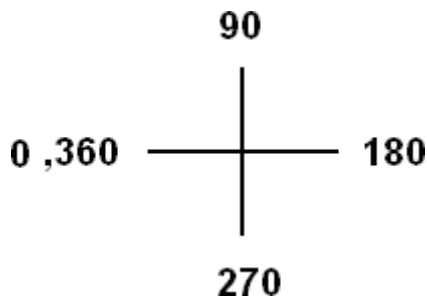


Fig: Standard Reference angle

Reverse Scale = True

For example: If you want  $0^{\circ}$  (Left) to  $180^{\circ}$  (Right) Meter for WHocess value range 0-100, set the following.

Start Angle:  $0^{\circ}$ , End Angle:  $180^{\circ}$  and Reverse Scale = True.

## Behavior

**Step:** It is the minimum value to reflect change of pointer position in Meter.

For example: By default, Step = 0, i.e., pointer moves its position in Meter in Real time even with minor change in WHocess value.

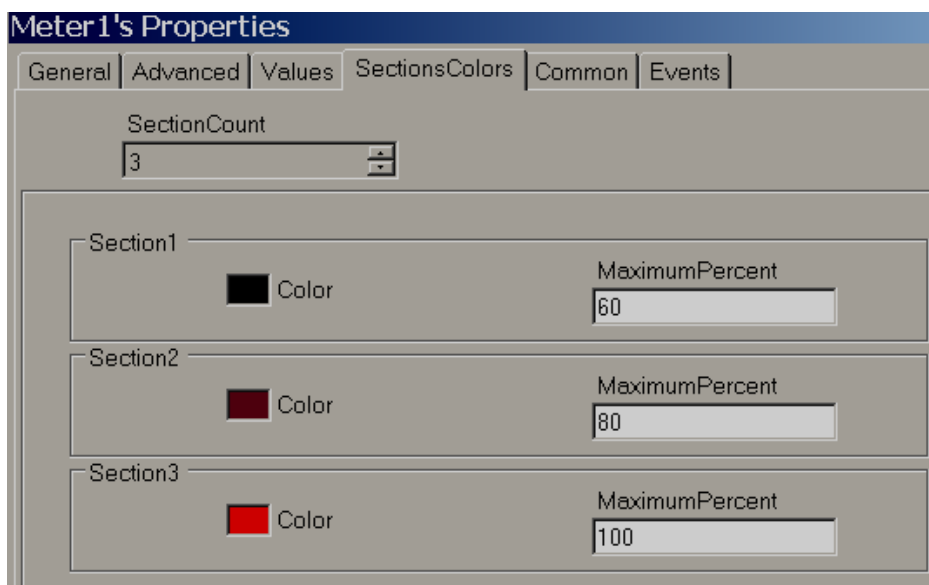
For example: Step = 5, i.e., pointer moves its position in Meter in Real time in steps of 5.

**Value:** It is used to enter WHocess value in design time and check pointer position in PC.



**Indicator only:** By default, it should be selected such that the meter will be used for Read only purpose. If it is not selected, then, you can use the Meter for Write purpose similar to Slider to send set point from Recorder to PLC etc. Just use finger and move pointer to change set point.

**Write design time value:** If selected, it writes design time value instead of default value defined at tag data base.



### **Sections colors:**

It is configure bands for the sections to show different colors for Labels and Ticks in Meter.

Example: Three bands

Section 1, Max % = 60 that means, its band is from 0 to 60 % it shows labels and ticks in black color.

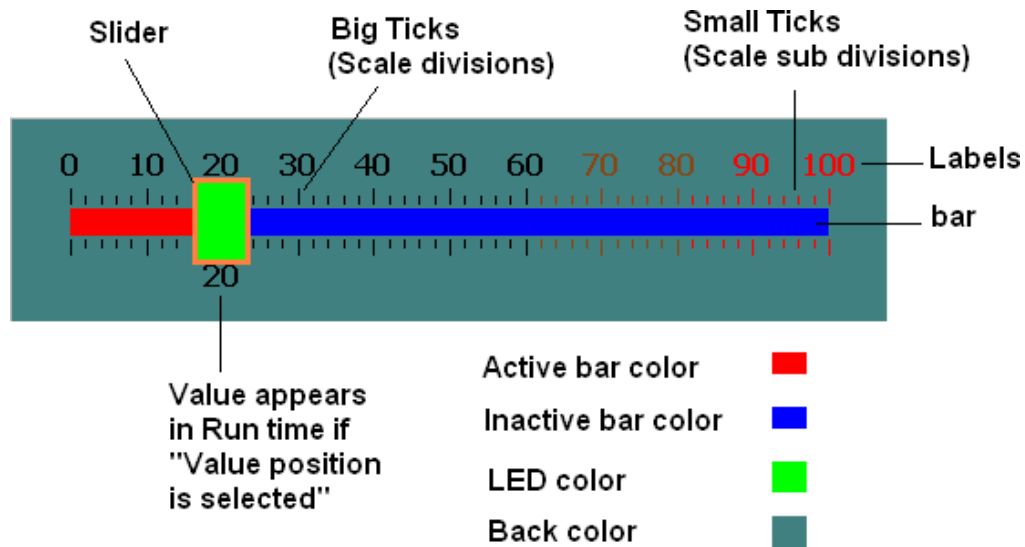
Section 2, Max % = 80 that means, its band is from 61 to 80 %.

Section 3, Max % = 100 that means, its band is from 81 to 100 %.

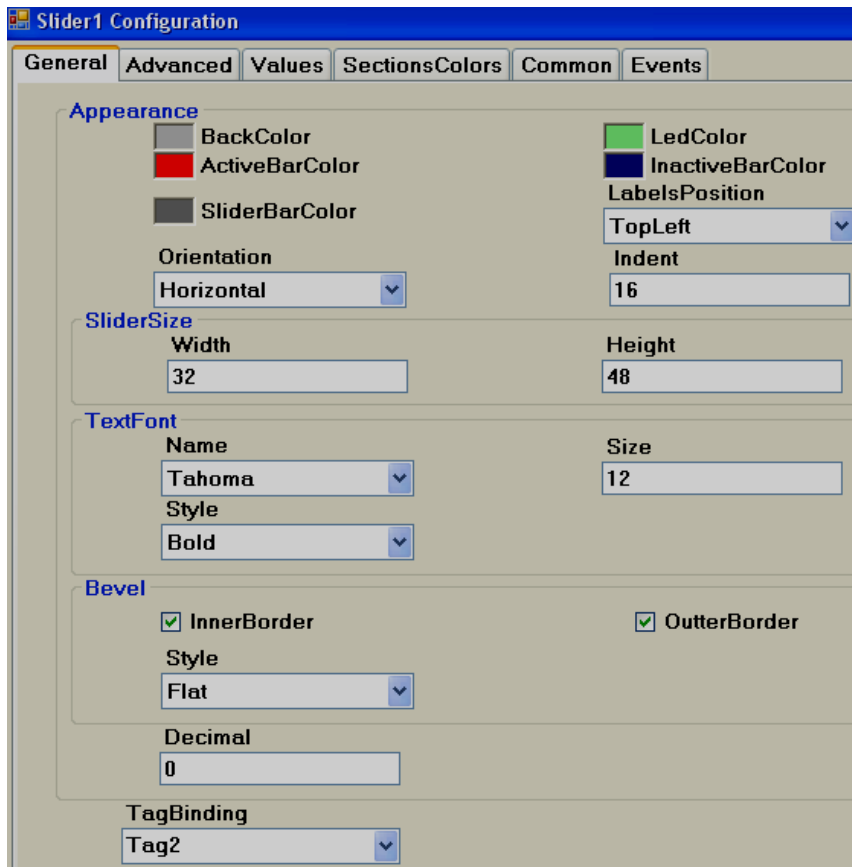
Note: Band setting is in % for the total Scale defined (Minimum to maximum).

### 5.3.18.4 Slider

This is normally used to change set point of WHocess by operator from Recorder in Run time. Generally it is linked with Analog type tag (Analog output type tag at PLC, to send 4-20 mA signal out from PLC for external Controllers, Variable speed drives etc).



In above fig, Scale divisions = 10 (Big ticks).  
Scale sub divisions = 5 (Small ticks between big ticks).  
Scale Label divisions = 10 (0, 10, 20 till 100).



## WHoperties

**Back color:** Back color for the component.

**Active bar color:** Define active bar color.

**Slider bar color:** Define border color for the slider.

**LED color:** Color of the handle

**Inactive bar color:** Define inactive bar color.

**LabelsPosition:** Define Labels position. Available options include Top Left, Bottom Right, Both, Internal and None.

**Orientation:** Horizontal/Vertical. This is orientation of Slider component and in above figure, it is Horizontal direction.

**Slide size:** Define height and width of the slider.

**Text Font:** It is to set font for the label including Name of Font, Size of font and Style of font. Supported styles include Regular, Bold, Italic, Underline & Strikeout.

**Bevel:** It is to set border including inner border, outer border and style of border.

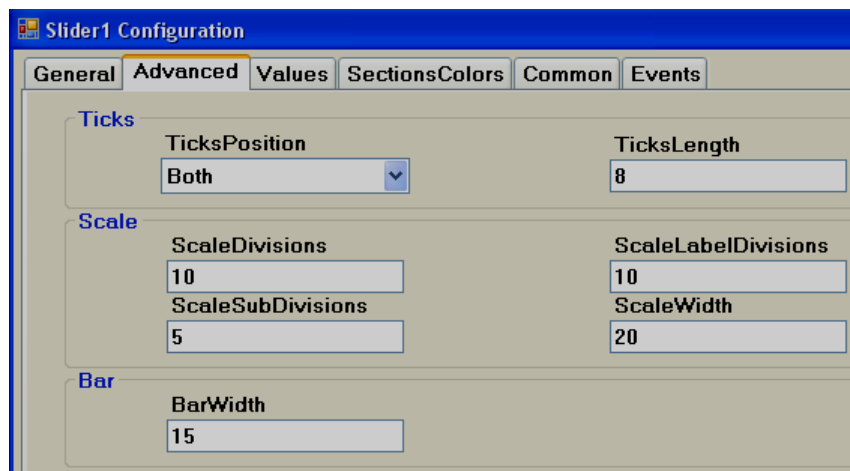
Inner Border: True/False

Outer Border: True/False

Style: 9 styles are available

None, Flat, Single, Double, Raised, Lowered, Double Raised, Double lowered, Frame Raised, Frame Lowered.

**Tag Binding:** Select the Analog Tag of WHocess value.



**Ticks:**

**Ticks Position:** Define ticks position. Available options include Top Left, Bottom Right, Both, Internal and None.

**Ticks Length:** Set Tick length in pixels

**Scale:**

**Scale divisions:** Define number of Scale divisions (Big ticks).

**Scale Sub Divisions:** Define number of Sub divisions (Small Ticks between big ticks).

**Scale Label Divisions:** Define number of Labels to appear like 0, 10, 20 etc. till 100 for scale 0 to 100.



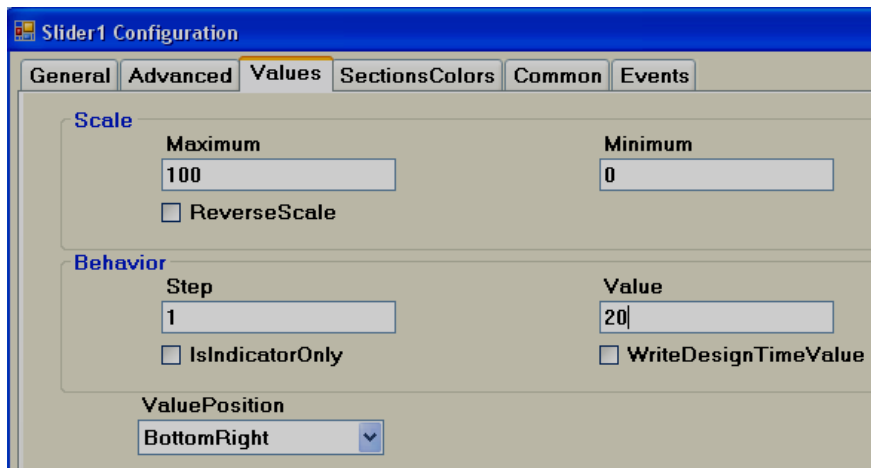
Define same value for both Scale divisions and Scale label divisions.

**Scale Width:** Define Scale width.

Note: This is only width for Scale divisions. Example: If ticks position is selected on both sides, then it is gap between two scale ticks (Top and Bottom in Horizontal orientation or Left and Right in vertical orientation).

**Bar:**

**Bar Width:** Define width of Bar.



**Scale:**

**Maximum:** This is maximum range of Set point (Analog Tag, Normally Analog Output).

**Minimum:** This is minimum range of Set Point (Analog Tag, Normally Analog Output).

Example: If Controller set point is 0 to 100 Deg.C, set Minimum = 0, Maximum = 100.

**Reverse Scale:** If Selected, Scale labels will be displayed in Reverse.

**Behavior:**

**Step:** It is the minimum value to reflect change of the slider position.

For example: By default, Step = 0, i.e., Slider moves its position in Real time even with minor change in WHocess value.

For example: Step = 5, i.e., Slider moves its position in Real time in steps of 5.

**Value:** It is used to enter WHocess value in design time and check the Slider position in PC.

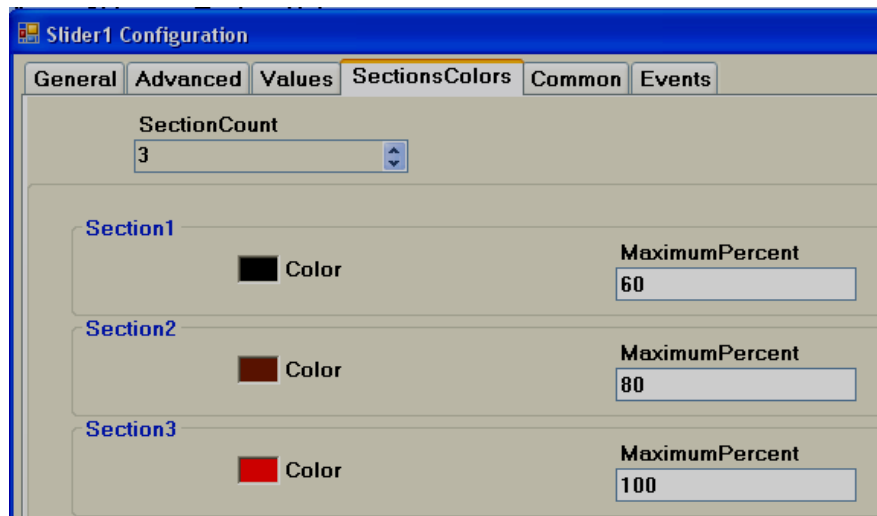
**Indicator only:**



If Indicator only is selected, slider is used for Read only. Operator will be not able to move slider in Run time.

If Indicator only is not selected, the slider is used for Read/Write. Operator will be able to move slider in Run time for example: change set point for variable speed drive.

**Value Position:** Define position for the value to appear in Run time. Available options include Top left, Bottom Right, Both, Internal and None.



**Sections colors:** It is configure bands for the sections to show different colors for Labels and Ticks in Slider.

Example: Three bands  
Section 1, Max % = 60 that means, its band is from 0 to 60 % it shows labels and ticks in black color.

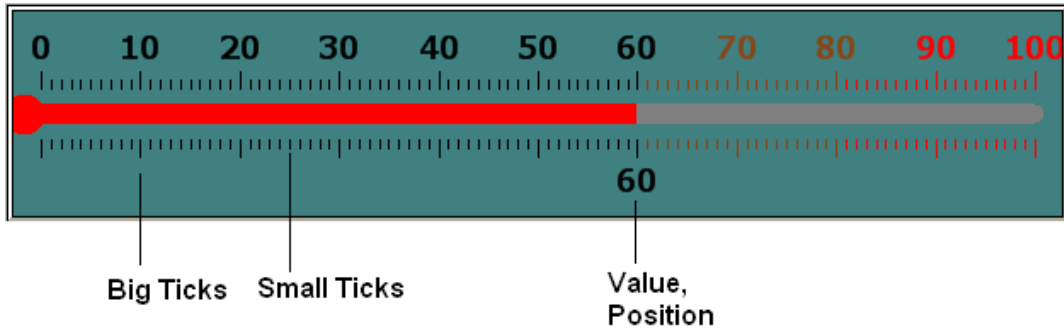
Section 2, Max % = 80 that means, its band is from 61 to 80 %, it shows labels and ticks in brown color.

Section 3, Max % = 100 that means, its band is from 81 to 100 %, it shows labels and ticks in Red color.

Note: Band setting is in % for the total Scale defined (Minimum to maximum).

### 5.3.18.5 Thermometer

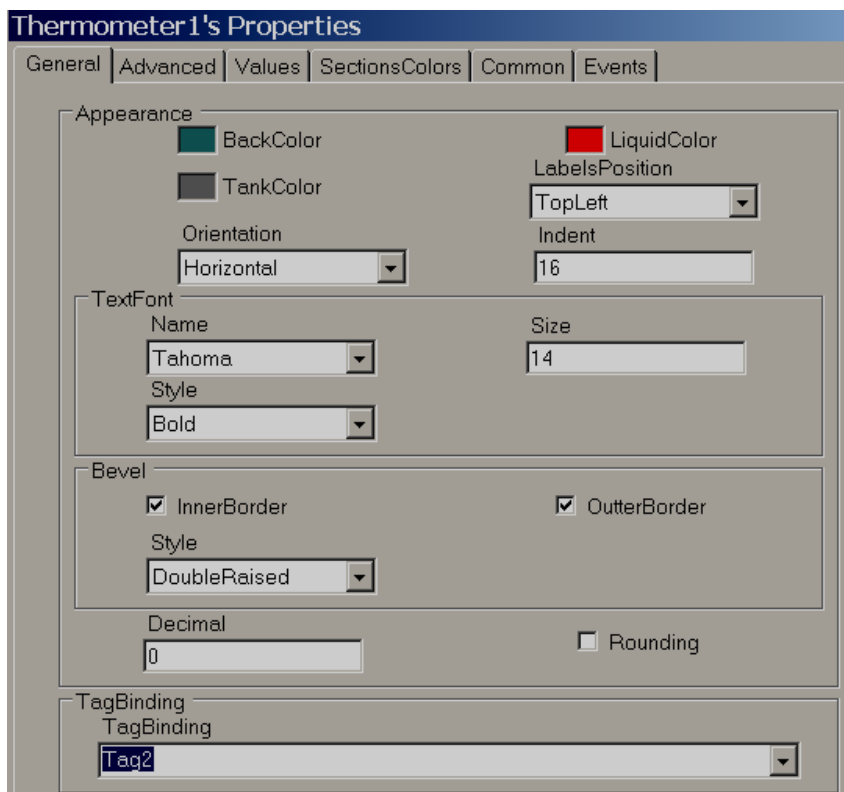
This is normally used to view WHocess temperature by operator in Run time. Generally it is linked with Analog type tag (Analog input type tag at PLC, which is received as 4-20 mA signal from field transmitters like Temperature etc...)



Scale Label Divisions= 10 (0, 10, 20... 100)

Scale Divisions = 10 (No.of Big Ticks)

Scale Sub Divisions = 10 (No.of Small ticks between Big Ticks)



## WHoperties

**Back Color:** Define back color for the component.

**Liquid color:** Shows temperature level (mercury) in Thermometer.

**Tank Color:** Define background color of thermometer without mercury.

**LabelsPosition:** Define Labels position. Available options include Top Left, Bottom Right, Both, Internal and None. The naming convention is based on selected orientation of component.

**Orientation:** Horizontal/Vertical. This is orientation of component and in above figure, it is Horizontal direction.

**Indent:** It is the gap between border and start of scale.

**Text Font:** It is to set font for the label including Name of Font, Size of font and Style of font. Supported styles include Regular, Bold, Italic, Underline & Strikeout.

**Bevel:** It is to set border including inner border, outer border and style of border.

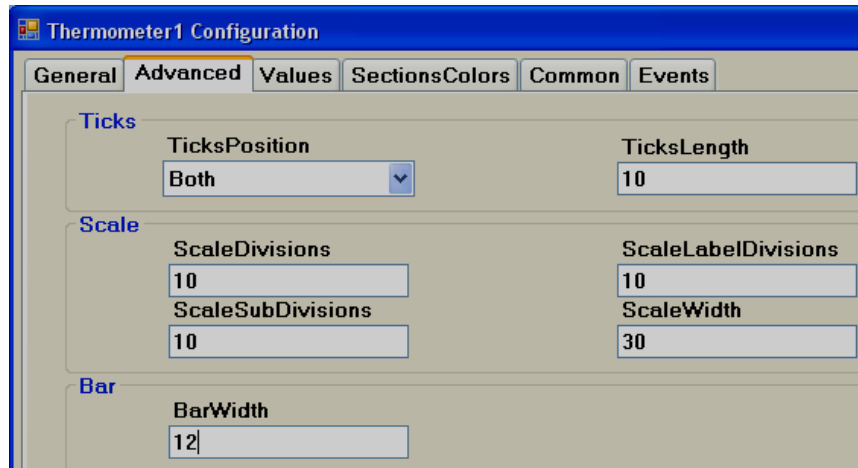
Inner Border: True/False

Outer Border: True/False

Style: 9 styles are available

None, Flat, Single, Double, Raised, Lowered, Double Raised, Double lowered, Frame Raised, Frame Lowered.

**Tag Binding:** Select the Analog Tag of WHocess value.



**Ticks Position:** Define ticks position. Available options include Top Left, Bottom Right, Both, Internal and None.

**Ticks Length:** Set Tick length in pixels

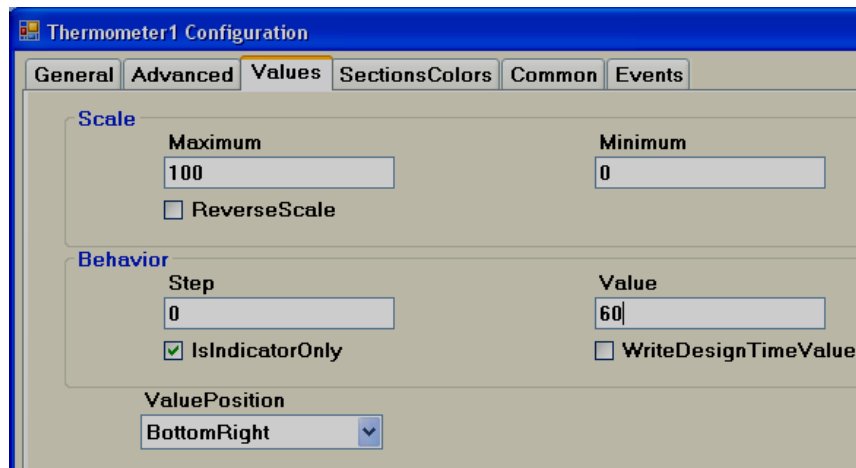
**Scale divisions:** Define number of scale divisions (Big Ticks) for the component.

**Scale Sub Divisions:** Define number of Sub divisions between the above scale divisions (Number of Small ticks between any two Big Ticks).

**Scale Label Divisions:** Define number of Labels to be displayed for component as per Scale Range of WHocess value. For ex: 0, 10, 20, 30...100.

**Scale Width:** Define Scale width. If you have ticks on both sides of component, then, it defines width between Upper (Left) and Lower (Right) scale divisions based on orientation of component.

**Bar Width:** Define width of Bar in pixels.



**Maximum:** This is maximum range of Set point (Analog Tag, Normally Analog input, 20 mA, 10V DC etc.)

**Minimum:** This is minimum range of Set Point (Analog Tag, Normally Analog input, 4 mA, 0V DC etc.)

Example: If Temperature transmitter range is 0 to 100 Deg.C, set Minimum = 0, Maximum = 100.

**Reverse Scale:** True/False. Define Scale direction.

**Step:** It is the minimum value to reflect change of mercury level.

For example: By default, Step = 0, i.e., Mercury level moves in Real time even with minor change in WHocess value.

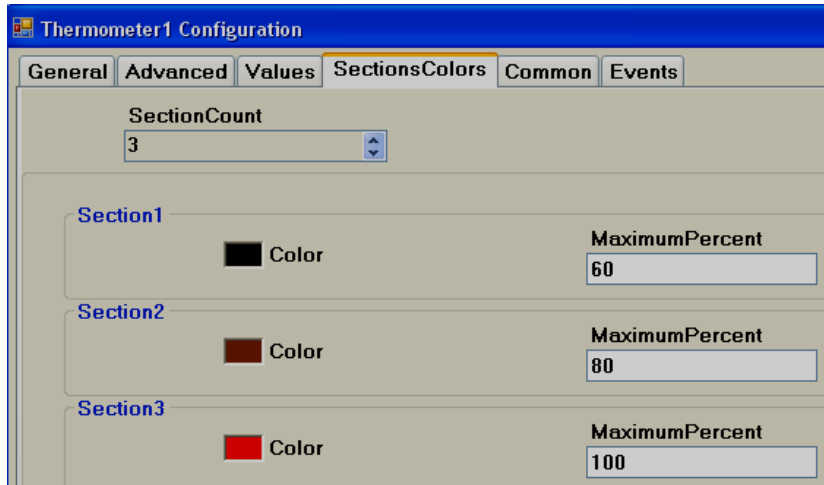
For example: Step = 5, i.e., Mercury level moves its position in Real time in steps of 5.

**Value:** It is used to enter WHocess value in design time and check mercury level position in PC.

**Indicator only:** If selected, then, this component is used for Read only. If it is not selected, then, this component can be used for Write/Read purpose.

**Write design time value:** If selected, it writes design time value instead of default value defined at tag data base.

**Value Position:** Define position for the value to appear in Run time. Available options include Top left, Bottom Right, Both, Internal and None. The naming convention is based on orientation of component.

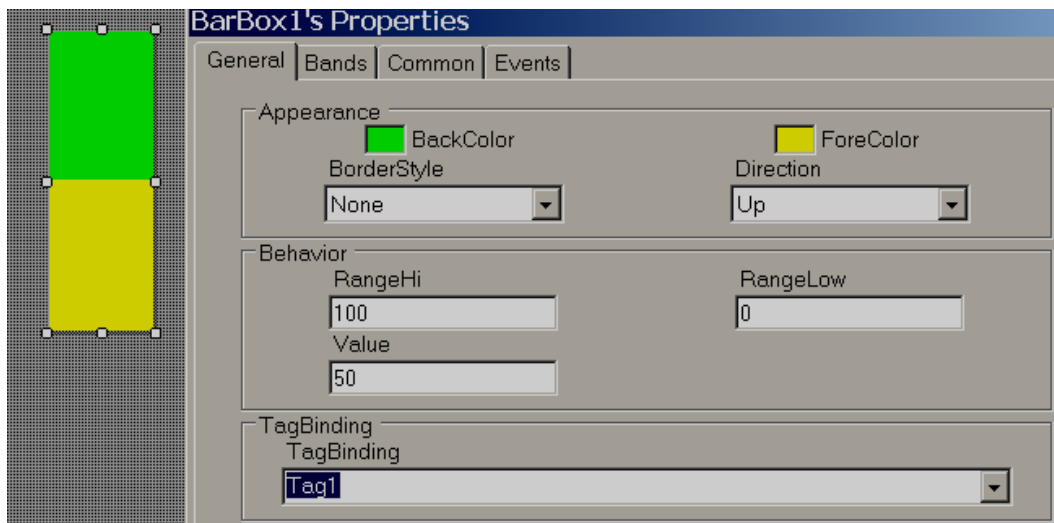


**Section Colors:** Define bands to display Ticks and Label color accordingly based on value of tag in Run time.

### 5.3.18.6 Bar Box

Bar Box is a Graphical User Interface widget display bar graph for Analog Tag in Run Time.

Every Bar box should be linked with **Analog** Tag.



### WHoperties

**Border Style:** Define border style. They include Fixed single, Fixed 3D and None.

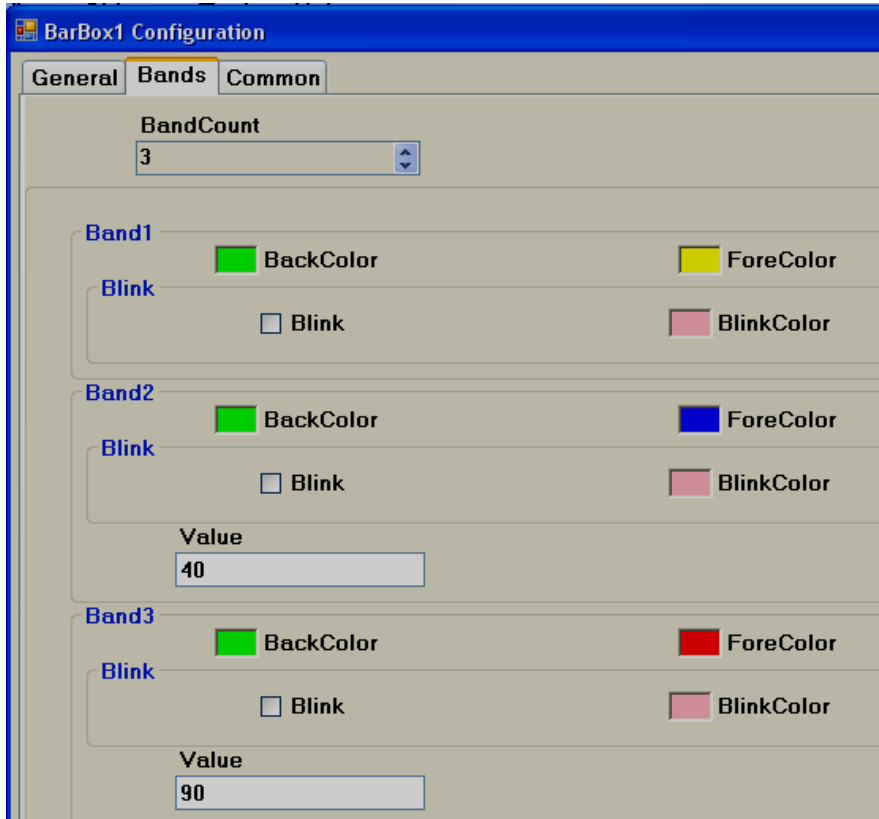
**Direction:** Define direction of Bar graph. Up/Down/Left/Right

**Range high:** Display scale high.

**Range Low:** Display scale low.

**Value:** Default value. It is to check how fore color, back color displays in PC during design time.

**Tag Binding:** Select the Analog Tag of WHocess value.



## **Bands**

It is to define various bands for the WHocess value to appear and display animation in Run time.

**Band count:** Use up/down buttons to increase/decrease number of bands. Maximum 32 bands are supported. In each band, it is possible to configure back color, fore color and blink WHoperties.

**Back color:** Define back color.

**Fore Color:** Define fore color.

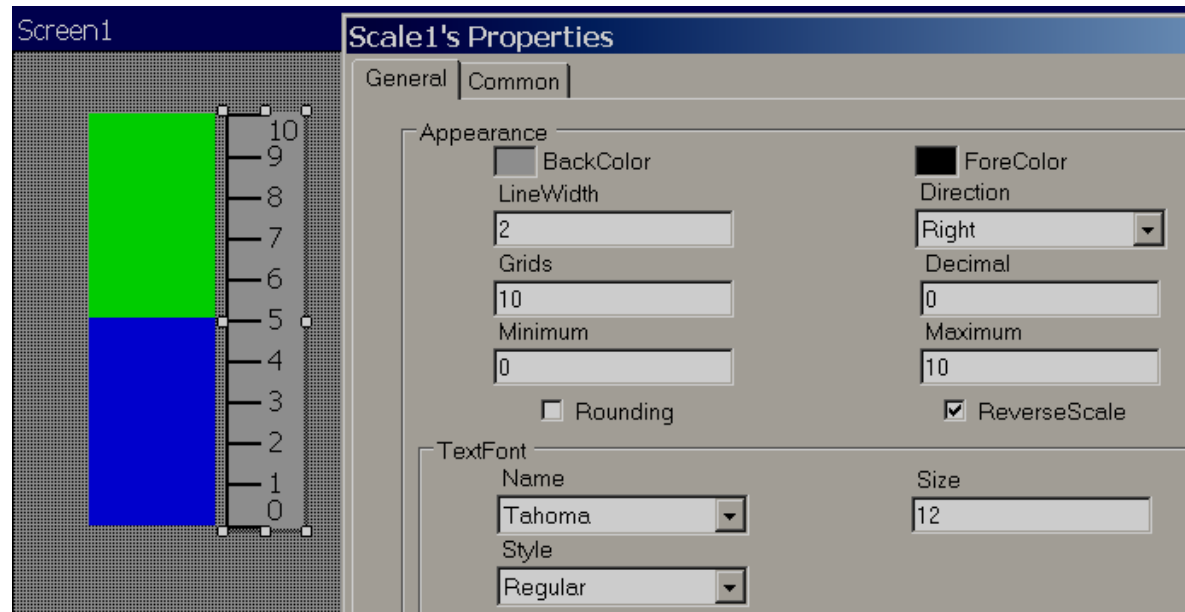
**Blink:** Select "True" if blink is required and "False" if blink is not required.

**Blink color:** If "True" is selected for blink, then, this WHoperty is visible and select required blink color.

**Value:** It is the band range. For the first band, it is always Range Low value defined for bar box. Band 1 high range is value defined at Band2. Band 2 high range value is value defined at Band3 so on.

### 5.3.18.7 Scale

Scale is a Graphical User Interface widget used along with bar box if required.



#### **WHoperties**

**Back color:** Define back color

**Fore Color:** Define fore color

**Line width:** Define width of line

**Grids:** Define number of grids

**Direction:** Define direction of Scale. Up/Down/Left/Right

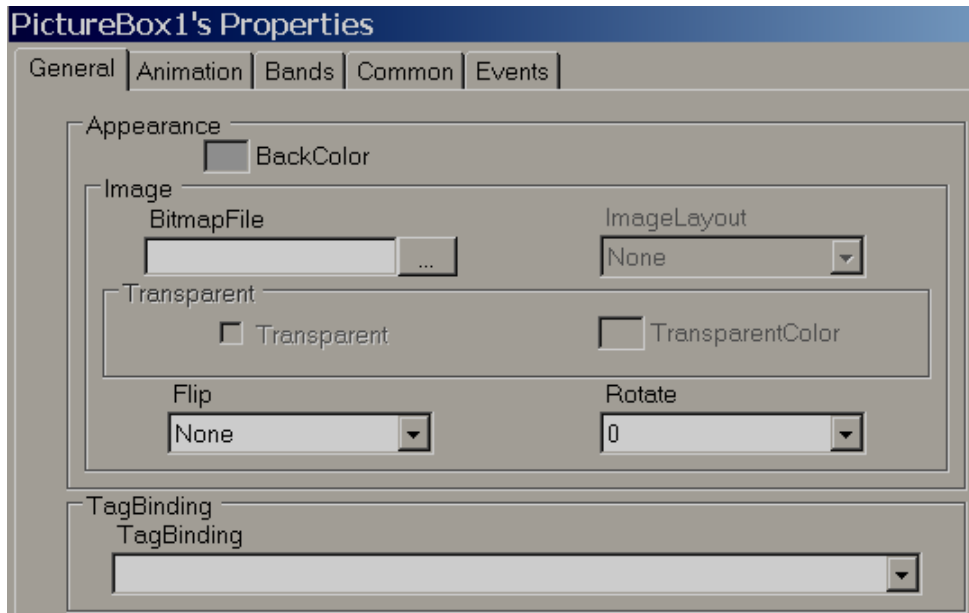
### 5.3.18.8 Picture box

Picture box permits the user to link different picture file into Picture box component during design time and then later view them in Run time based on value of Tag. Supported formats includes

Bitmap file (\*.bmp)

Windows Metafile (\*.wmf)

JPEG File (\*.jpg)  
 Graphics Interchange format (\*.gif)  
 Portable Network Graphic (\*.png)



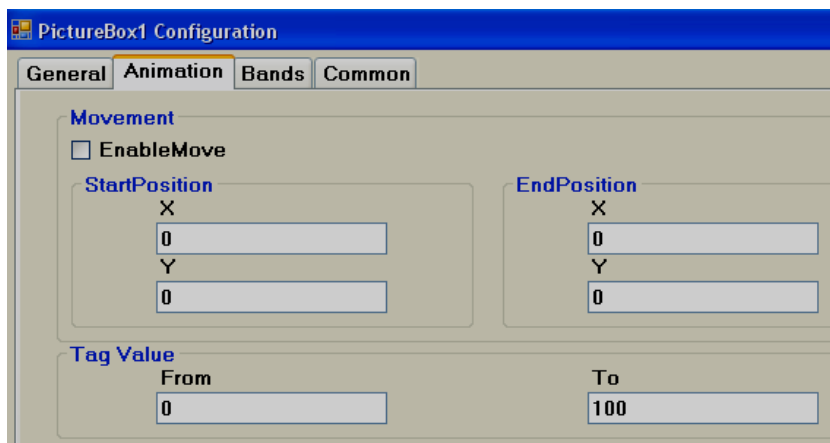
### WHoperties

**Bitmap file** Select the image to be shown in the object

**Flip:** It is to flip picture file in design time. Available options are Horizontal, Vertical, Both and None.

**Rotate:** It is to select direction for the picture file in design time to adjust direction. Available directions include  $0^\circ$ ,  $90^\circ$ ,  $180^\circ$  and  $270^\circ$

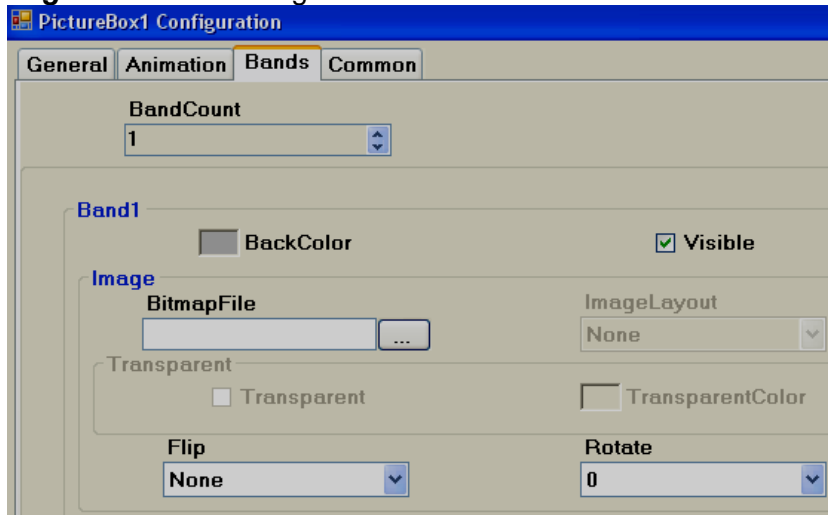
**Tag Binding:** Select the Analog tag to be linked with Picture box.



**Movement:** Select Enable Move if it is required to move picture in Run time from Location 1 to Location 2 based on tag Value. Start and End coordinates

for X and Y needs to be configured in Design time and Picture moves in Run time based on Tag value.

### **Tag Value:** Define Tag value



**Band Count:** Define number of bands required.

**Back Color:** Define back color for the selected picture file in specific band.

**Visible:** Define visibility for the picture in specific band.

**Bitmap file:** Select picture file for specific band.

**Image Layout:** Position of image with in Picture container. Available options include None/Center/Stretch. When stretch is selected, it attempts to fit picture file to the size of container.

**Transparent:** Select if no back color is required for picture file.

**Flip:** It is to flip picture file in design time. Available options are Horizontal, Vertical, Both and None.

**Rotate:** It is to select direction for the picture file in design time to adjust direction. Available directions include  $0^{\circ}$ ,  $90^{\circ}$ ,  $180^{\circ}$  and  $270^{\circ}$

Example: You may take a photo of a section of the factory floor like a tank and use this in Recorder screen instead of default symbols.



If a bitmap file by name sunset.jpg is linked with Picture box1 in screen1. If you wish the same sunset.jpg in screen no2, do not create picture box and link with sunset.jpg again. Since a resource with name sunset already available, if you try to use the same image in other place, it may not allow you to do so and may WHompt with error message. If you really need the same image again, copy picture box1 at screen1 and paste it in screen no 2.

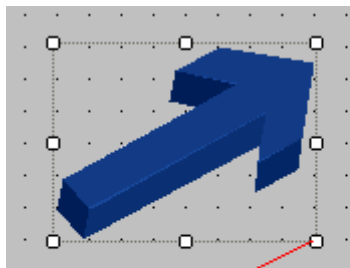
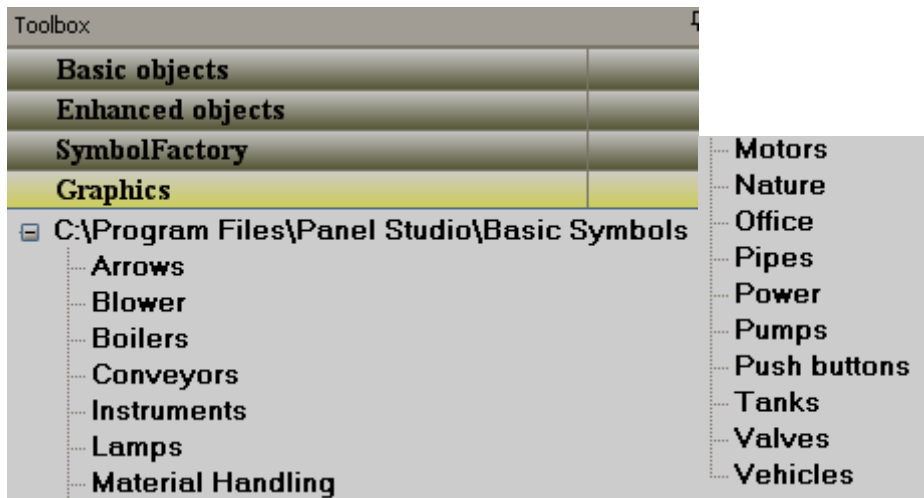
### 5.3.19 Graphics

It is to select a symbol in screen like a Tank, Motor etc... Basic symbols are available in Recorder Editing Software and it includes the following symbol categories.

#### Symbol categories

	Category	Symbols	Colors	Qty
1	Arrows	7	6	42
2	Blowers	5	6	30
3	Boilers	4	6	24
4	Conveyors	6	6	36
5	Instruments- True Color	7	C	7
6	Lamps	4	6	24
7	Material handling	8	C	8
8	Motors	4	6	24
9	Nature-True Color	6	C	6
10	Office-True Color	7	C	7
11	Pipes	10	6	60
12	Power-True Color	7	C	7
13	Pumps	5	6	30
14	Push buttons	8	6	48
15	Tanks	5	6	30
16	Valves	8	6	48
17	Vehicles-True Color	6	C	6

C = True Color



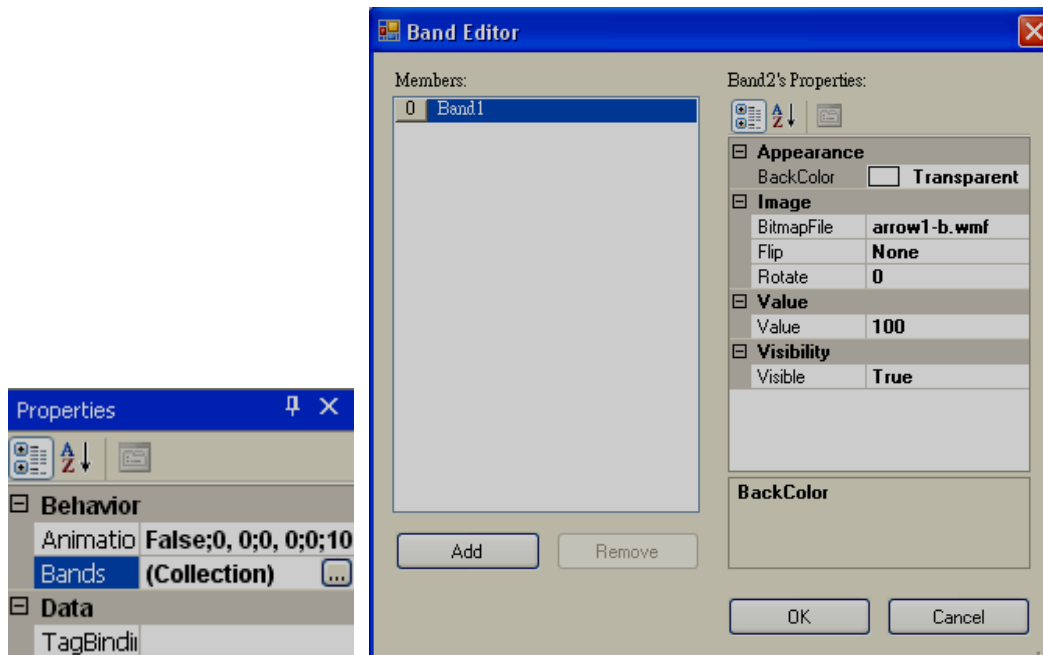
**Use these cursor points to change the size**

Some symbols are available with 6 different colors in Red, Green, Yellow, Blue, Brown and Grey.

All the symbols are vector graphics, occupies less memory space with high quality.

It is possible to set transparent WHoperty for symbol in design time from WHoperty grid. Transparent means screen color itself will appear as back ground color. Also, it is possible to change symbol back ground color during design time and Run time.

*How to set transparent WHoperty to symbol from WHoperty grid*



Click at ... at Bands and then select Back Color = Transparent

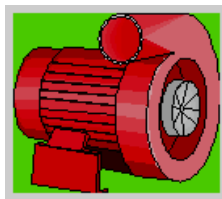
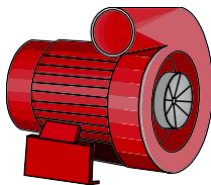


Fig: Back color=Transparent

Fig: Back Color=Green color

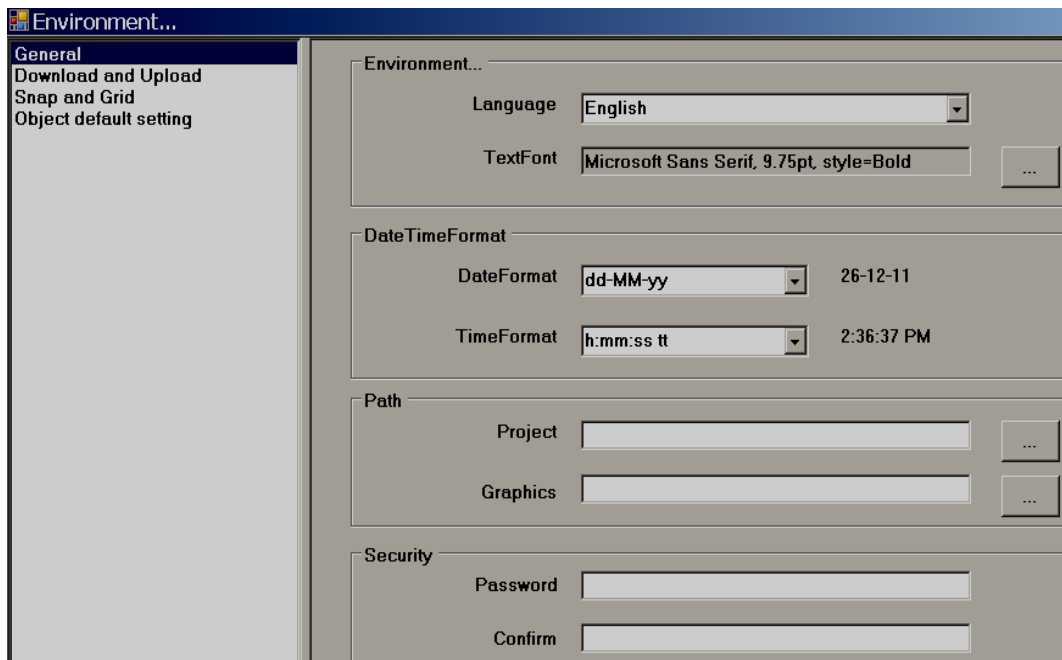
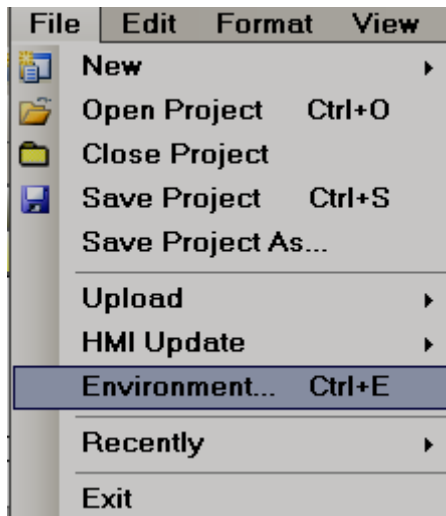
Since all are vector symbols, if symbol is enlarged, it does not lose quality.

When Recorder Editing Software is installed, all the basic symbols will be installed at default folders C:\WHogram Files\Recorder Editing Software\Recorder Editing Software\Basic Symbols

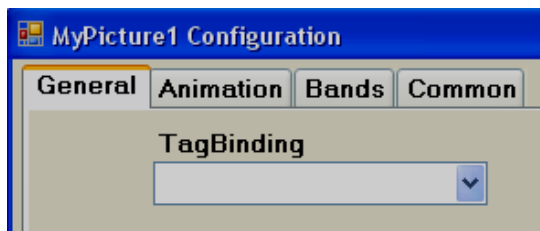
However, if applications developer has any additional symbols, they can be arranged in folders and placed along with standard basic symbols and keep them in above path.

Example: Create a folder by name "Custom" and copy it to C:\WHogram Files\Recorder Editing Software\Recorder Editing Software\Basic Symbols

It is possible to set path for graphic symbols in Recorder software. In Menu bar, Click on "File", then select "Environment" and then select "Graphics path" such that all these will appear in a tree structure directly with in Recorder editor such that no need to import these kind of symbols using special component "Picture Box".

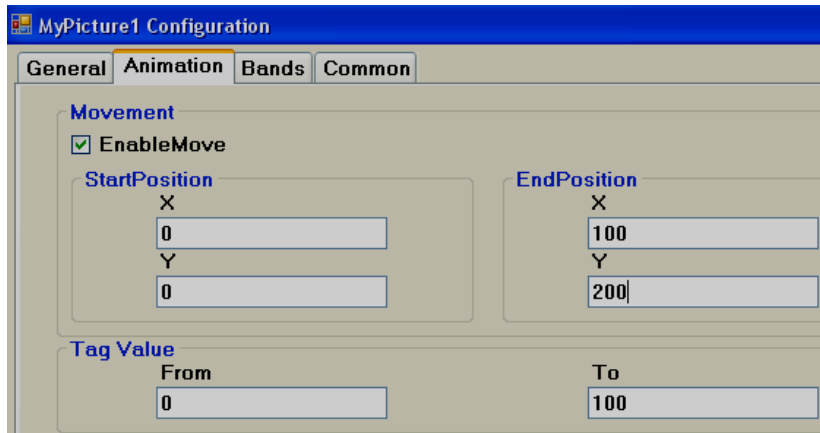


Once symbol is selected in Recorder from Graphics, then if required it is possible to change Flip or rotate basic symbols in  $0^{\circ}$ ,  $90^{\circ}$ ,  $180^{\circ}$  and  $270^{\circ}$



### **WHoperties**

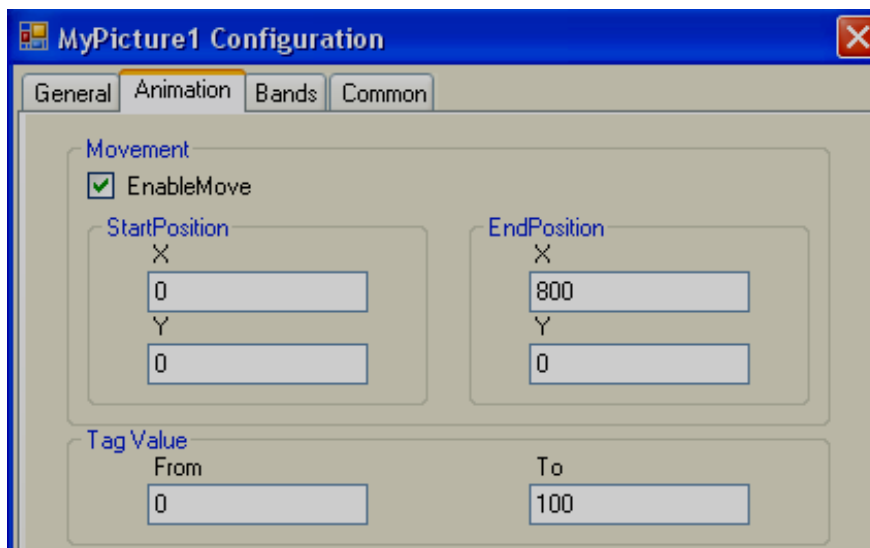
**Tag Binding:** Select Analog Tag if animation is required for the symbol in Run time.



**Movement:** Select Enable/Move and then, enter X and Y start and end positions in pixels.

**Tag Value:** It is linked with Start and End Positions.

**Ex: Recorder 7" (High Performance), Screen Resolution = 800 X 480, Horizontal installation, Width=800, Height=480. Move symbol from Left to Right in screen at Run time when tag value changes from 0 to 100**

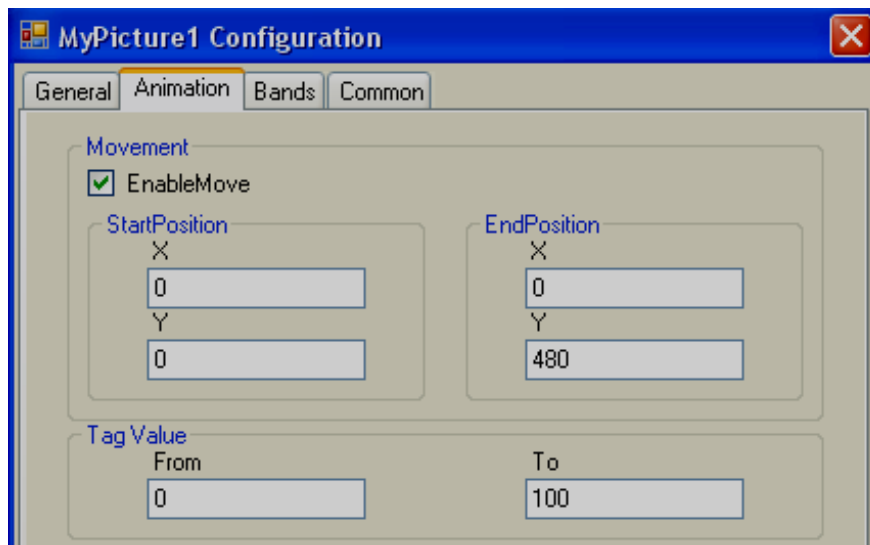


To move symbol from Left to Right, set start and end Positions for X coordinate in pixels and there is no need to set Y coordinates.

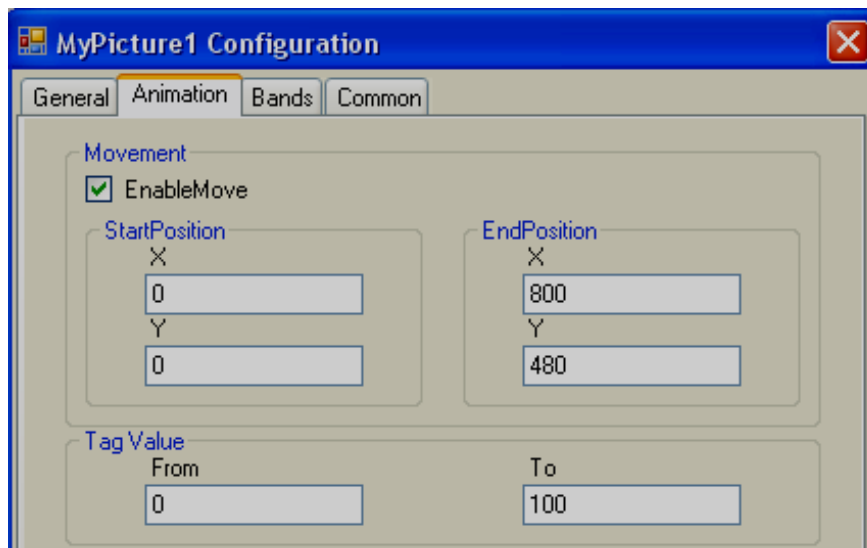
Tag value = 0 corresponds to Start Position (X)

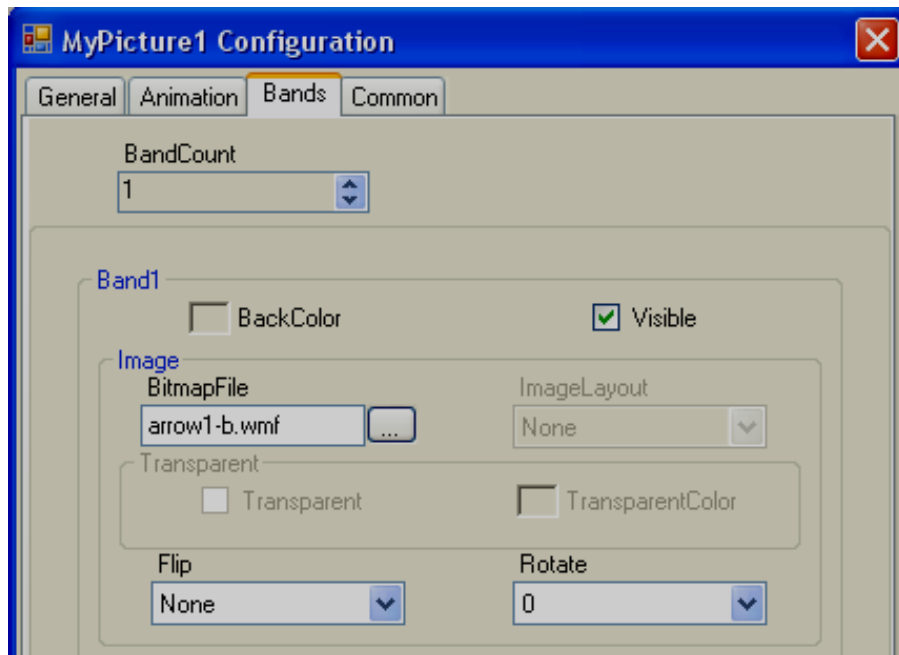
Tag value = 1000 corresponds to End Position (X)

**Ex: Recorder 7" (High Performance), Screen Resolution = 800 X 480, Horizontal installation, Width=800, Height=480. Move symbol from Top to Bottom in screen at Run time when tag value changes from 0 to 100**



**Ex: Recorder 7" (High Performance), Screen Resolution = 800 X 480, Horizontal installation, Width=800, Height=480. Move symbol from Left Top to Right Bottom in screen in angle at Run time when tag value changes from 0 to 100**





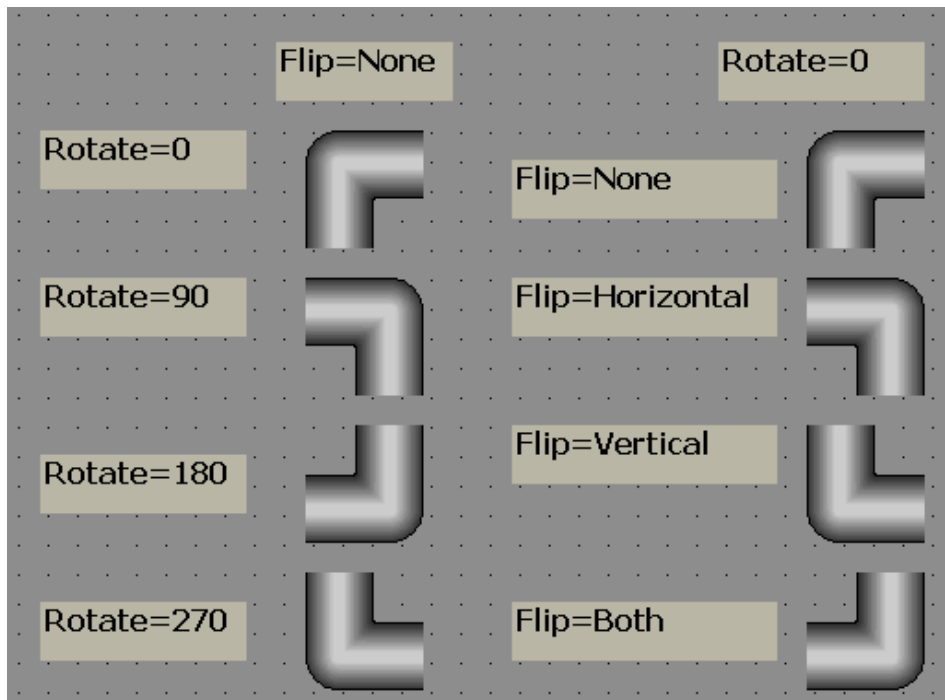
**Band Count:** It is to define bands for run time animation of symbol. Max. 32 bands are supported.

**Back Color:** Define Back Color of symbol to appear in specific band in Run time.

**Visible:** Define visibility control for symbol in specific band in Run time.

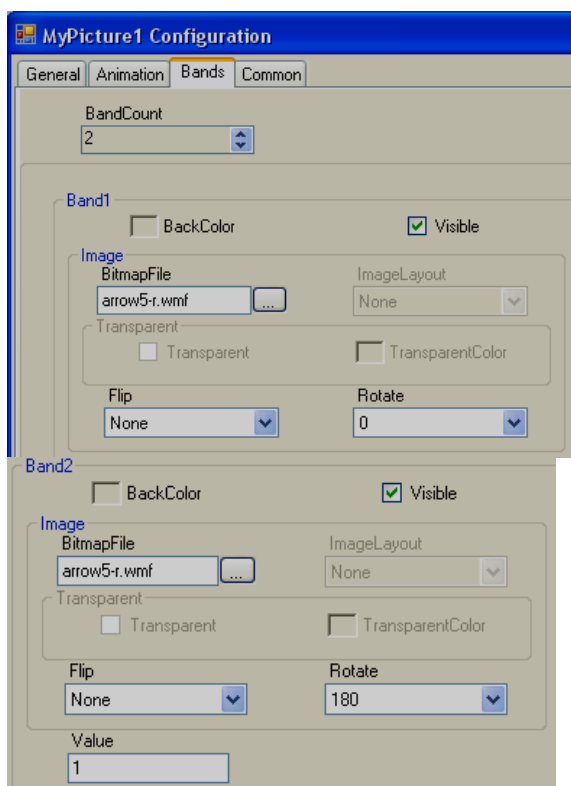
**Image:** Select different image file if required to display in specific band in Run time.

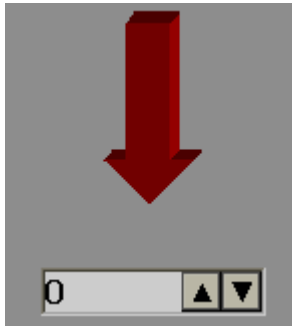
**Flip:** Define flip position for the symbol in specific band in Run time. Available options include None, Horizontal, Vertical and Both.



**Rotate:** Rotate symbol to any WHedefined direction in specific band at Run time. Available options include 0°, 90°, 180° and 270°

Example: There is Liquid level Tank. When, Tag value =0, an arrow should appear in Down direction indicating discharge of tank is in WHogress and when Tag value = 1, arrow should appear in Up direction indicating filling of tank is in WHogress.





### 5.3.20 Symbol Factory

Symbol Factory® contains more than 4000 symbols in 64 categories.

No.	Category	Symbols	No.	Category	Symbols
1	3-D Pushbuttons Etc.	73	35	Machining	90
2	Air Conditioning	140	36	Maps and Flags	23
3	Architectural	49	37	Material Handling	118
4	Arrows	63	38	Mining	63
5	ASHRAE Controls & Equipment	100	39	Misc. Pipes	39
6	ASHRAE Ducts	86	40	Misc. Symbols 1	57
7	ASHRAE Piping	49	41	Misc. Symbols 2	79
8	Basic Shapes	86	42	Mixers	24
9	Blowers Etc.	34	43	Motors	38
10	Boilers	36	44	Nature	71
11	Buildings	42	45	Operator Interface	28
12	Chemical	50	46	Panels	14
13	Computer Hardware	38	47	Pipes	82
14	Computer Keys	68	48	Plant Facilities	52
15	Containers	56	49	Power	61
16	Controllers	35	50	WHocess Cooling	20
17	Conveyors, Belt	40	51	WHocess Heating	61
18	Conveyors, Misc.	26	52	Pulp & Paper	35
19	Conveyors, Simple	56	53	Pumps	99
20	Ducts	51	54	Safety	27
21	Electrical	83	55	Scales	36
22	Finishing	45	56	Segmented Pipes	41
23	Flexible Tubing	24	57	Sensors	55
24	Flow Meters	35	58	Tank Cutaways	23
25	Food	72	59	Tanks	145
26	General Mfg.	68	60	Textures	181

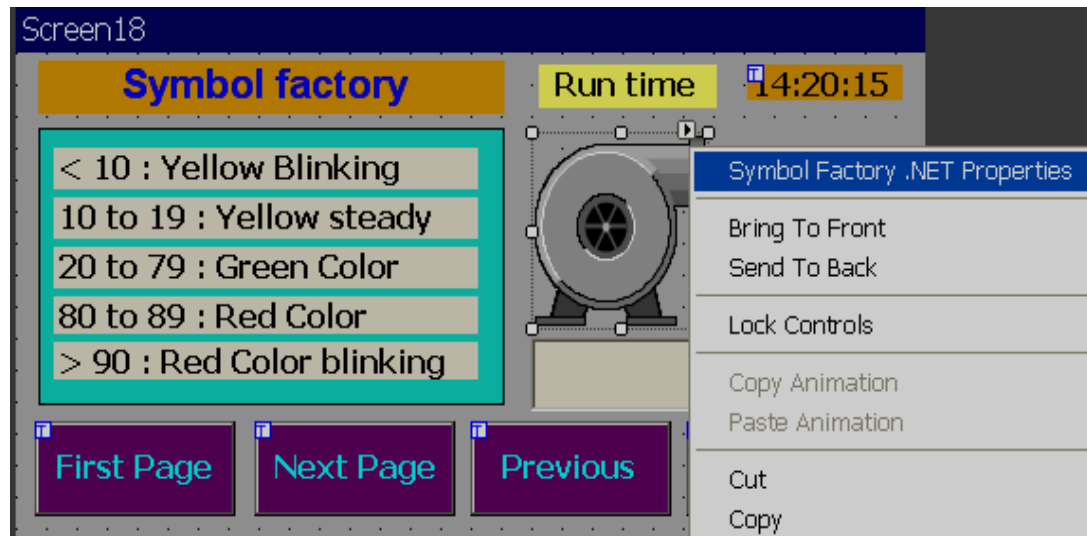
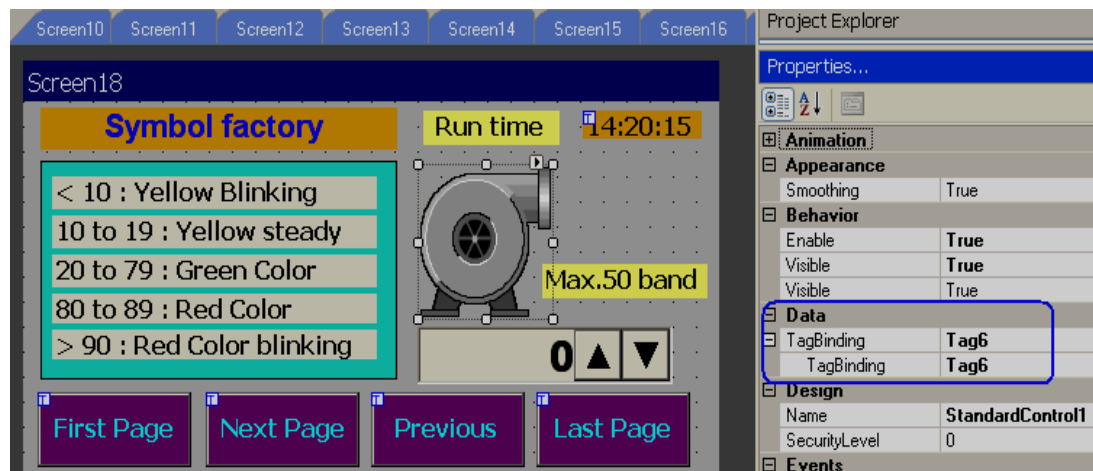
27	Heating	108	61	Valves	73
28	HVAC	74	62	Vehicles	41
29	Icons and Bitmaps	159	63	Water & Wastewater	112
30	Industrial Misc.	19	64	Wire & Cable	21
31	International Symbols	42		Total	4045
32	ISA Symbols	183			
33	ISA Symbols (3-D)	123			
34	Laboratory	23			

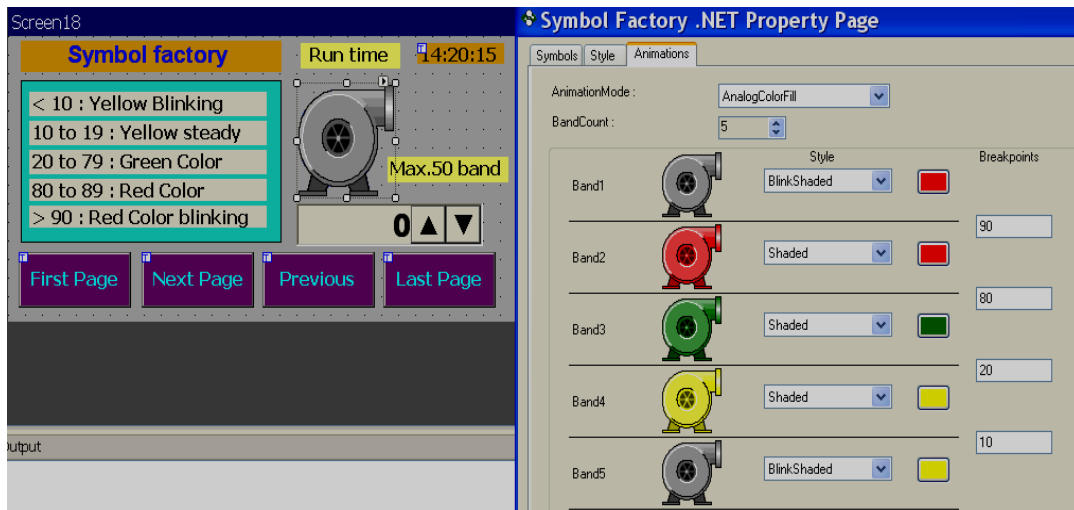


With Recorder Editing Software, only first symbol from symbol factory can be selected. If you need all symbols, order Recorder Editing Software Plus software and we will supply USB hardware lock to access more than 4000 symbol factory graphics



***It is possible to link Analog Tag with Symbol factory graphic and change colors in Run time. 50 bands are supported***



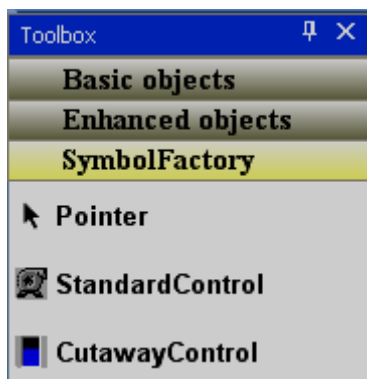


## Design Time

In design time it allows to you to change colors of these symbols by application engineer.

Example: Change tank color from standard grey scale to Green color.

## Task: Place symbol on a screen



In Tool box, click on “Symbol Factory” and then, drag and drop standard control to screen.

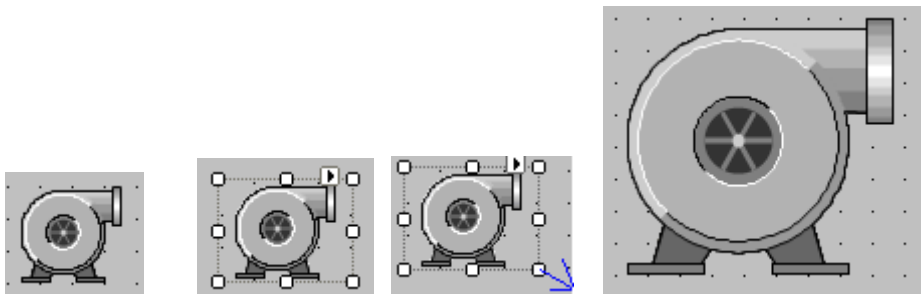


Fig 1

Fig2

Fig3

Fig4

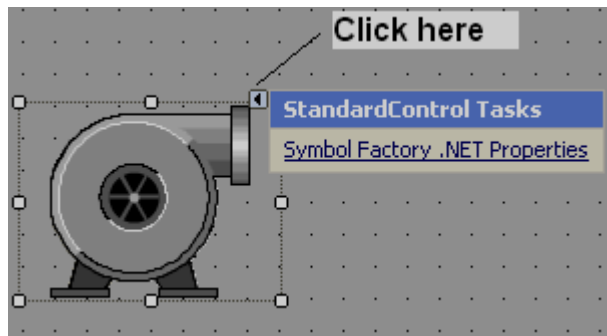
### Task: Increase size of symbol

Select the symbol in screen and it will be as shown as Fig2

Then, move mouse to a square pointer till arrow appears and then hold left click at mouse and drag to increase size of symbol as per your requirement and then it will be as shown in Fig4. Alternatively, in WHoperty grid, enter size in pixels as shown attached.

Size	120, 100
Height	100
Width	120

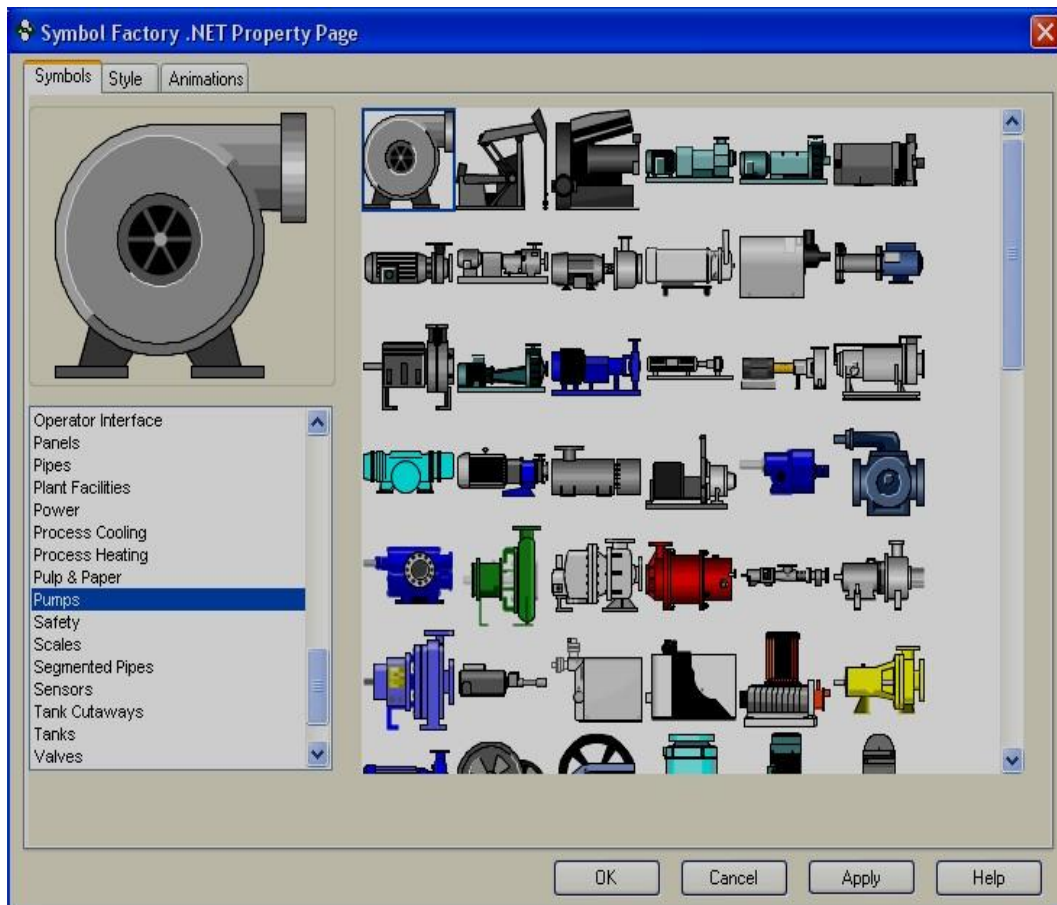
### Task: Changing symbol to another category



Drag and drop symbol factory component into screen.

Click on  and then click on Symbol Factory.NET WHoperties.

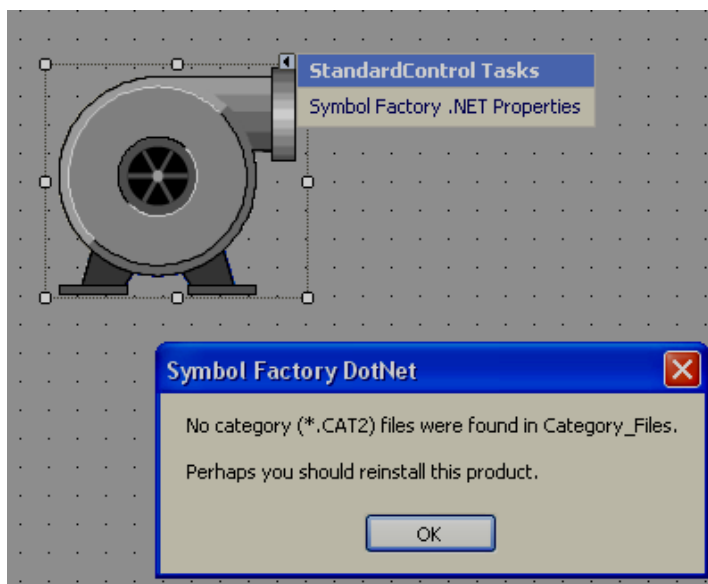
Alternatively, select the symbol factory component using single click (left) by mouse, keep mouse cursor on symbol, then, double click (left) in mouse to open symbol WHoperties, then, it shows following screen.



Select the required category, select the symbol and click on button “OK”, then new symbol will be placed in screen.



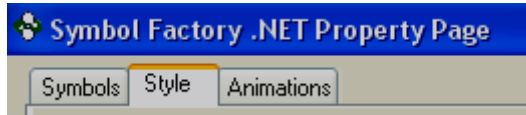
Click on Help in above screen to open Chm type help file (English) for symbol factory.



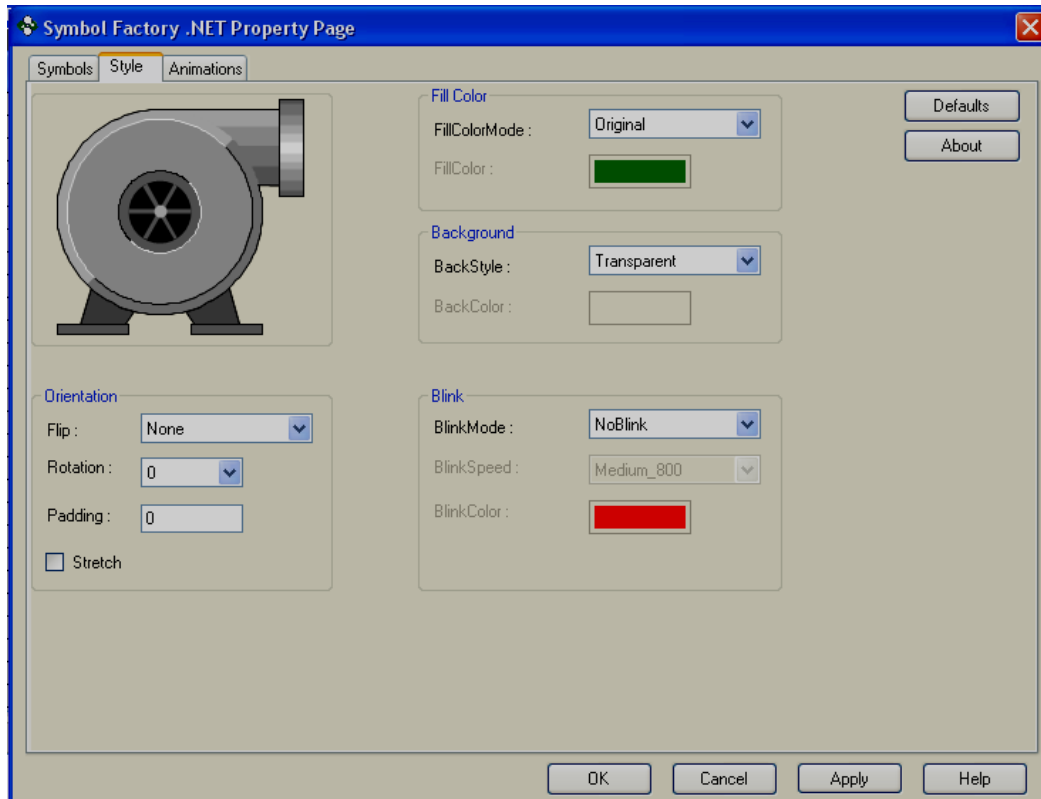
If above error message appears, then, it is required to reinstall symbol factory.

## Style

It is to define style of symbol in design time.



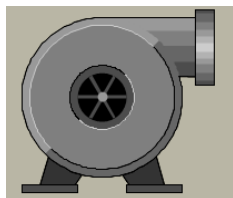
Click on “Style”, then “following screen will appear.



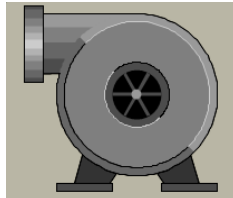
**Fig: Default Style settings**

### **Orientation:**

**Flip:** It is possible to flip symbol in Design time and available options include Horizontal, Vertical, Both and None.



Flip=None



Flip = Horizontal

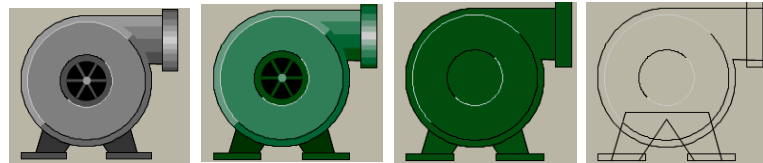
**Rotation:** It is possible to rotate symbol in design time and available options include 0°, 90°, 180° and 270°

**Padding:** Normally it is 0. It is used to decrease size of symbol with in selected boundaries.

**Stretch:** It is used to stretch symbol with in selected boundaries.

**Fill Color:**

**Fill color mode:** Available options include Original, Shaded, Solid and Hollow.



Fill Color Mode: Original	Shaded	Solid	Hollow
Fill Color: N.A	Green	Green	N.A

**Fill color:** Define color to be filled in Shaded and Solid fill color mode.

**Background:**

**Back Style:** Available options include Transparent & Opaque. Transparent means screen background color will appear for symbol. Opaque means, it is possible to set different background color for specific selected symbol.

**Back color:** Define background color when back style = Opaque.

**Blink:**

**Blink mode:** Available options include No Blink, Blink Invisible, Blink shaded and Blink Solid.

**NoBlink:** Blink is not required for symbol either in design time or Run time. Blink Speed and Blink color = Not available for selection.

**BlinkInvisible:** Symbol will appear and disappear cyclically in both design time and Run time as per set Blink speed. Blink color: Not Available for selection.

**BlinkShaded:** Symbol will flash, total 2 colors, one color at a time on same symbol as per set blink speed in both design time and Run time.

Example

Fill Color mode = Shaded, Color = Green

Blink shaded setting: Blink mode=Blink shaded, Blink speed = Medium\_800, Blink color = Blue

Then, green color shaded symbol appears first time, then symbol turns into blue color shade after elapsing time at blink speed setting.

**Blink speed:** Define blink speed. Available options include Fast\_400, Medium\_800, Slow\_1200. Its period is in *ms*.

**Blink color:** Define background color



Normally, blink is not used in design time and default settings will be as follows

1. Fill Color Mode = Original. If different color is required for symbol, select Fill color mode = Shaded and then define Fill color
2. By default, Back Style = Transparent in Background
3. By Default, Blink mode = NoBlink

### **Animation**

It is to define animation for the symbol to appear at Run time in Recorder.

#### **Animation mode:**

Define animation mode. Available options include Analog Color Fill, Discrete color fill, Analog integer color fill.

**AnalogColorFill:** Select this option if you wish to link analog type tag and then define band for the colors. For ex: 0 to 10, Color = Yellow, 10-90, Color = Green, 90-100, Color = Red etc..(See next section "How beak points work for more details)

**DiscreteColorFill:** Select this option if you wish to pass discrete values like 1,2,3... in Run time to the Tag linked with symbol for display of different colors. See next section "How beak points work for more details)

**AnalogIntegerColorFill:** This is same as Analog color fill, but only integer value is passed to the Tag linked with symbol. See next section "How beak points work for more details)

**Band count:** Define number of bands required for selected Animation mode

**Styles:** Define style of symbols. Available options include Original, Shaded, Solid, Blink Invisible, Blink shaded and Blink solid. All definitions are same as explained earlier.

### 5.3.20.1 How break points work

The idea behind Breakpoints is that certain animation will occur when a WHoperty of the component changes. If this change falls within the defined parameters (see below), an animation will be triggered

**Please note:** The screen shots in the examples below are based upon the Symbol Factory .NET Standard Control, but the same WHinciple applies to the Cutaway control.

Two types of animation can be defined based upon the setting of Animation Mode: Analog Break Points and Discrete Break points

#### **Analog Break points (Animation Mode = Analog integer color fill or Analog color fill)**

Analog breakpoints are defined as a value on which an animation will trigger when a WHoperty on the component reaches that level. Depending upon your component, different WHoperties will need to be changed depending upon the setting of Animation Mode. These WHoperties are:

Component	Animation Mode Setting	WHoperty that Changes to trigger an Animation
Standard	AnalogColorFill	AnalogValue1
Standard	AnalogIntegerColorFill	AnalogIntValue1
Cutaway	AnalogColorFill	Level
Cutaway	AnalogIntegerColorFill	LevelInt

#### Number and Ordering of Breakpoints

The number of breakpoints available to you is the number of bands defined minus 1. As a breakpoint is defined as the point to which an animation changes, make sure you arrange the breakpoints from high to low. So, for example, suppose you had this screen:



When the value of your WHoperty changes, this is what will happen to the control:

Value of WHoperty	Band that is Active	Appearance of Component
Less than 10	Band5	Blink Shaded Red
10 to < 20	Band4	Display Shaded Yellow
20 to < 80	Band3	Original
80 to < 90	Band2	Display Shaded Yellow
Greater than 90	Band1	Blink Shaded Red

If you do not order your breakpoints in descending order, your results will be unWHedictable.

### Discrete break points (Animation mode = Discrete color fill)

Discrete Breakpoints aren't really breakpoints - instead, they enable animation if the "DiscreteValue" of an element in the BandsCollection is set to true.

However, since multiple DiscreteValue WHoperties can be set at the same time, how does the component determine the animation to display? What it does is give WHiority to the animations based upon their order in the BandsCollection. If the first band in the collection (by default, Band1) has its DiscreteValue set to True, then that animation will be shown no matter which band also has its DiscreteValue set. As another example, if Band2 and Band5 each has their DiscreteValue set, the animation used will be the one defined in Band2.

Therefore, given the following definition of five bands:



Here is what the animations will be shown based upon different values of Discrete Value

Discrete Value for Band1	Discrete Value for Band2	Discrete Value for Band3	Discrete Value for Band4	Discrete Value for Band5	Appearance of Component
<b>True</b>	False	False	False	False	Blink Shaded Red (Band1)
False	<b>True</b>	False	False	False	Shaded Yellow (Band2)
False	False	<b>True</b>	False	False	Original (Band 3)
False	False	False	<b>True</b>	False	Shaded Orange (Band 4)
False	False	False	False	<b>True</b>	Blink Shaded Black (Band 5)

<b>True</b>	<b>True</b>	<b>True</b>	<b>True</b>	<b>True</b>	Blink Shaded Red (Band 1)
False	<b>True</b>	<b>True</b>	<b>True</b>	<b>True</b>	Shaded Yellow (Band 2)
<b>True</b>	False	False	False	<b>True</b>	Blink Shaded Red (Band 1)
False	False	False	False	False	Original (No bands active)

### 5.3.21 WWhoject Tools

Project	Help
Build	F6
Build And Offline Simulation	F7
Build And Online Simulation	F8
Online Simulation	
Stop	
Build And Download	
Download	
Project Status...	

### 5.3.22 Build

Once WWhoject is compiled successfully, it creates build and this file need to be transferred to Recorder. If any errors during WWhojection of build, it shows at output window just below to screen working area. If Output is not visible below screen working area, select it via Menu, "View", and then click at "Output" or apply "Reset window layout" from the Menu-"View"

Output
Screens preparing...
Screen1 images 0 / 0 objects 0 / 0
UserScripts checking...
Objects checking...
Alarms checking...
Scheduler checking...
Datalogs checking...
Recipes checking...
Build started...
Build succeeded.

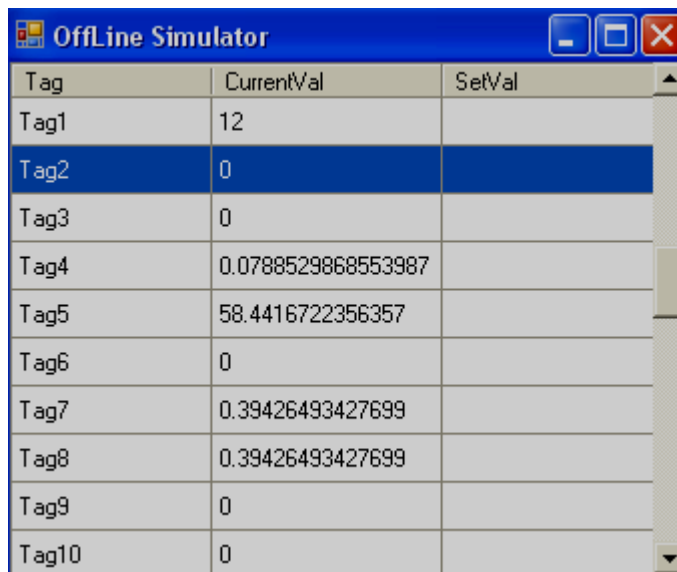


After creating build, if any errors are shown at Output window, do not attempt to download application from PC to Recorder or PC to USB flash disk for transferring it to Recorder. First clear the errors and make sure that compilation errors are not WHesent before transferring application to Recorder.

### 5.3.23 Build & Offline Simulation

First it creates build and then Run Offline simulation.

It is to test application in PC before downloading application to the Recorder, without connecting PLC to either PC or Recorder. It is possible to enter some values for the tags via table to check how the application appears in run time at PC itself with out downloading application to Recorder or connecting PLC.




Tag	CurrentVal	SetVal
Tag1	12	
Tag2	0	
Tag3	0	
Tag4	0.0788529868553987	
Tag5	58.4416722356357	
Tag6	0	
Tag7	0.39426493427699	
Tag8	0.39426493427699	
Tag9	0	
Tag10	0	

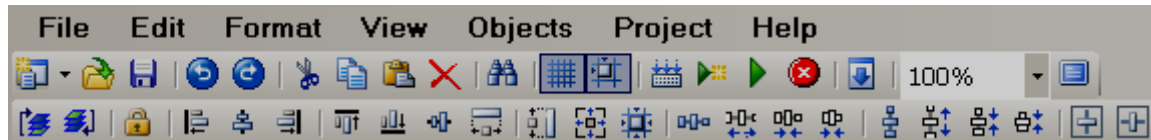
Enter value at “SetVal” caulmn and then WHess enter key in keyboard, then, it accepts and shows at “CurrentVal”, then, you will be able to see these values in objects linked with specific tag.



It is better to run offline simulation frequently say once in couple of hours or after completing specific screen editing by application engineer to verify how it works in Recorder such that if there are any compilation errors, it is easy to locate and rectify them to save time.

### 5.3.24 Stop

It is used to stop simulation WHogram in PC. When Offline simulation is running in PC, click on  Icon in PC to stop the current running simulation.





If Offline simulation or online simulation is already running in PC and user attempts to run it again, build will fail. It WHompts error message similar to the following

#### Screen1

#### Build Started....

**Could not write to Output file “C:\WHogram Files\WWhoject\Recorder\Panel.exe”  
“The WHocess cannot access the file because it is being used by another  
WHocess”**

#### Build Failed

In case if the above message is WHompted, click on Stop icon  couple of times and make sure that icon  is not available in Task bar. Again click on “Build” once and then run simulation.

### 5.3.25 Build & Download

It is to build first and then download application from PC to Recorder.

### 5.3.26 Download

It is to download application from PC to Recorder

Available options

- i) PC to Recorder via Ethernet
- ii) Removable Disk to Recorder via USB flash disk

### ***PC to Recorder via Ethernet:***

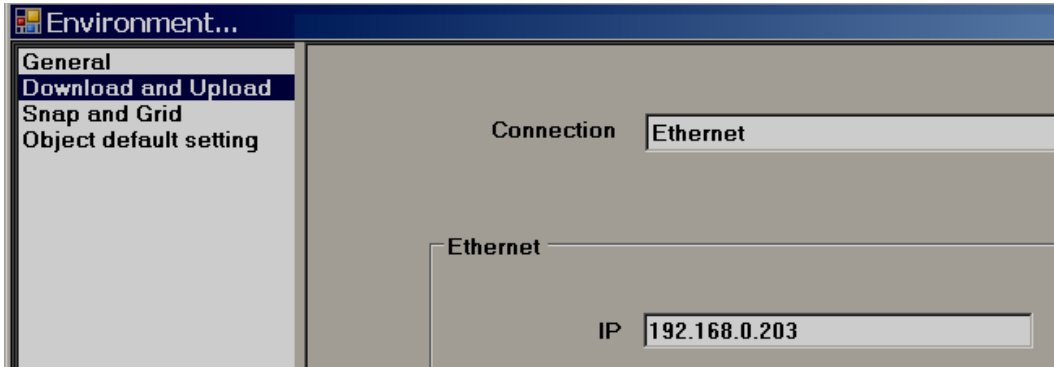
After creating application, create build in PC and make sure there are no compilation errors.

Connect Ethernet cable between PC and Recorder

In editor software, set Environment for Download via Ethernet and enter IP address of Recorder. In Environment, Select “Ethernet” at Download and then, Click at “OK” button.

In editor software, click at “WWhoject”, then click at “Download” or click at  icon.

It builds and transfers application from PC to Recorder. If there are any errors during compilation, it needs to fix compilation errors first and then download it again.




### ***Removable disk to Recorder***

After creating application, create build in PC and make sure there are no compilation errors.

Connect USB flash disk in to PC via USB port.

In Recorder editor software, set Environment for Download via Removable disk. In Environment, Select “Removable disk” at Download and then, Click at “OK” button.

In Recorder editor software, click at “WWhoject”, then click at “Download” or click at  icon.

It transfers application from PC to USB flash disk.

Insert USB flash disk in Recorder.

Switch on Power supply to Recorder. WHess at “Load”, select Path of WWhoject files and then WHess at “Load” button near path selection.

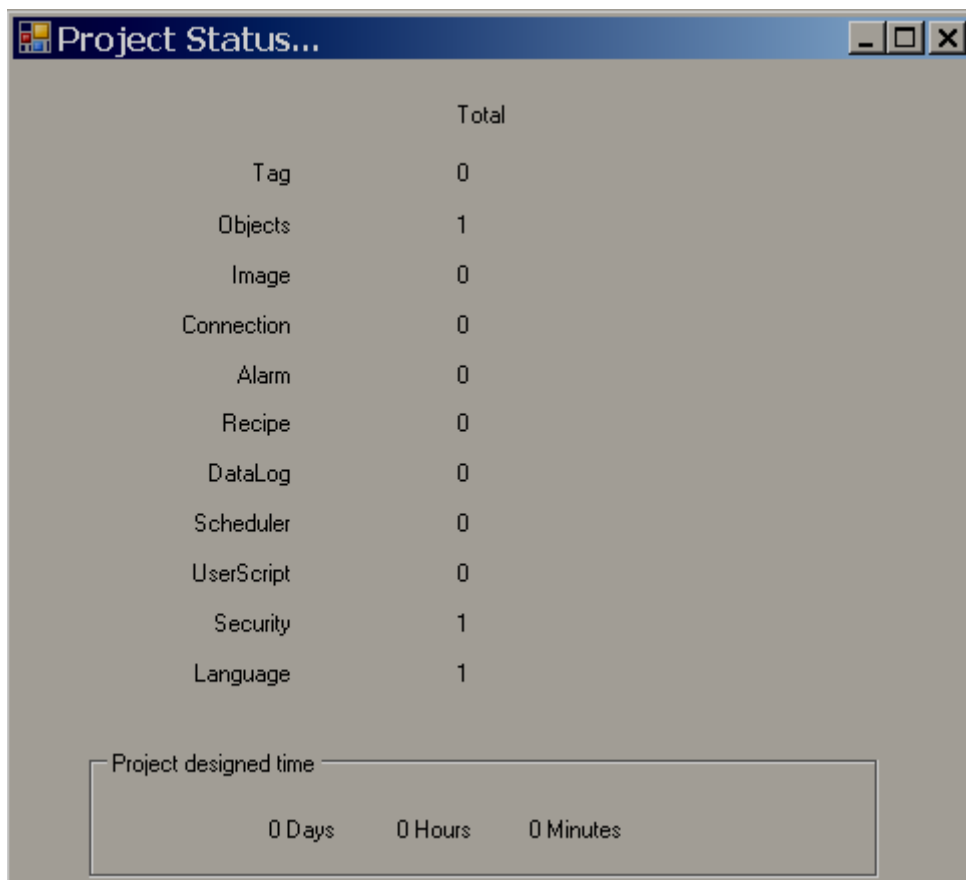
It transfers application from USB flash disk to Recorder.

### ***PC to Recorder via USB to Ethernet Converter***

For Low cost Recorder models, now Ethernet is an option. You can purchase USB to Ethernet converter and then it is possible to download application from PC to Recorder via Ethernet. Once USB to Ethernet converter is connected to Recorder, you can see IP address at the Recorder itself via system information similar to onboard Ethernet port

Note: The purpose of USB to Ethernet converter is to download application from PC to Recorder only.

### 5.3.27 WHOject status



The screenshot shows a window titled "Project Status..." with a table of WHOject status. The table has two columns: the category name and the "Total" count. Below the table is a section for "Project designed time" showing 0 Days, 0 Hours, and 0 Minutes.

	Total
Tag	0
Objects	1
Image	0
Connection	0
Alarm	0
Recipe	0
DataLog	0
Scheduler	0
UserScript	0
Security	1
Language	1

Project designed time

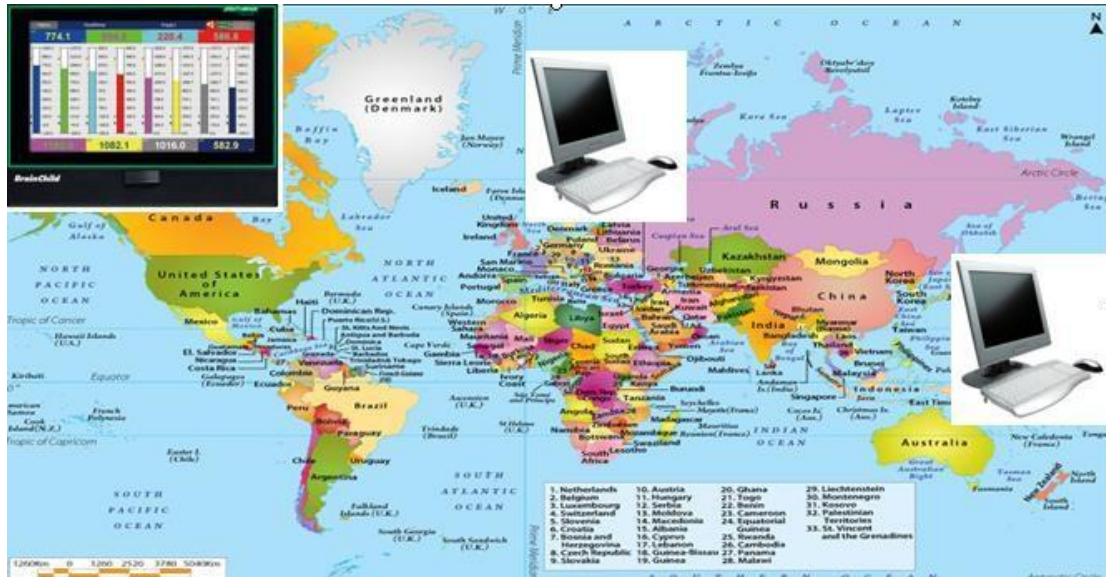
0 Days    0 Hours    0 Minutes

It is for WHOject management purpose to know limits and usage of objects.

**WHOject used time:** It shows how much time WHOject opened for editing purpose.

## 6. WEBSERVER

It is to view Paperless Recorder from Remote location via Internet.



### 6.1 Requirements

#### 6.1.1 Hardware

Recommended hardware:

PC with 3G GHz WHocessor, 512 MB RAM.

5.0GB free space in the hard disk.

Ethernet port, RJ 45 female.

#### 6.1.2 Operating system

Windows based Operating systems, Windows XP, Windows 7, Windows 8 etc..

32 bit and 64 bit operating systems are supported.

#### 6.1.3 Browser Requirements

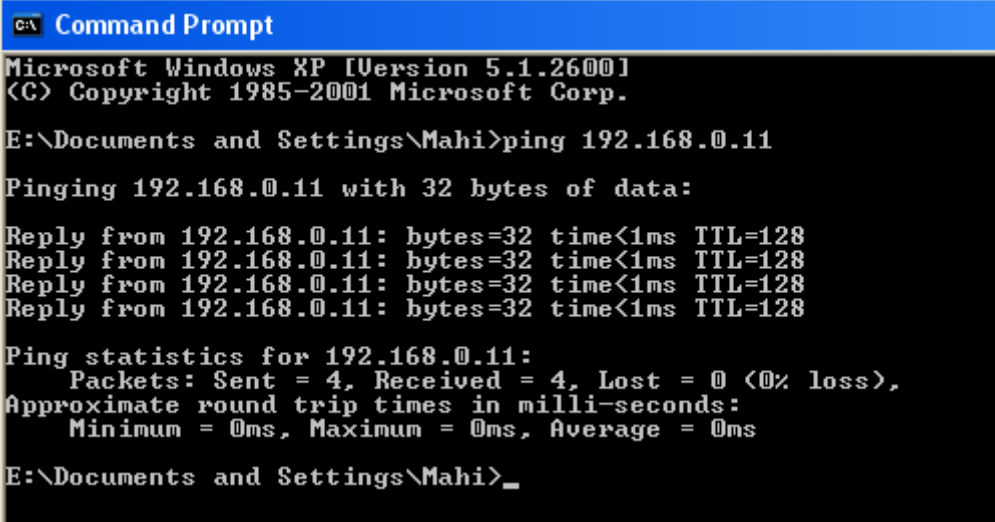
Internet Explorer 10 or higher.

Google Chrome.

## 6.1.4 IP Address Requirements

Static IP address Required for the Recorder.  
Obtain Static IP address from your Internet solution WHovider (ISP). This IP address should be unique at Internet.

Once IP address configured in the Recorder, use Ping Instruction from the dos WHompt first to verify if there is successful communication between Recorder and PC via Internet.



```
C:\ Command Prompt
Microsoft Windows XP [Version 5.1.2600]
(C) Copyright 1985-2001 Microsoft Corp.

E:\Documents and Settings\Mahi>ping 192.168.0.11

Pinging 192.168.0.11 with 32 bytes of data:

Reply from 192.168.0.11: bytes=32 time<1ms TTL=128
Reply from 192.168.0.11: bytes=32 time<1ms TTL=128
Reply from 192.168.0.11: bytes=32 time<1ms TTL=128
Reply from 192.168.0.11: bytes=32 time<1ms TTL=128

Ping statistics for 192.168.0.11:
    Packets: Sent = 4, Received = 4, Lost = 0 (0% loss),
    Approximate round trip times in milli-seconds:
        Minimum = 0ms, Maximum = 0ms, Average = 0ms

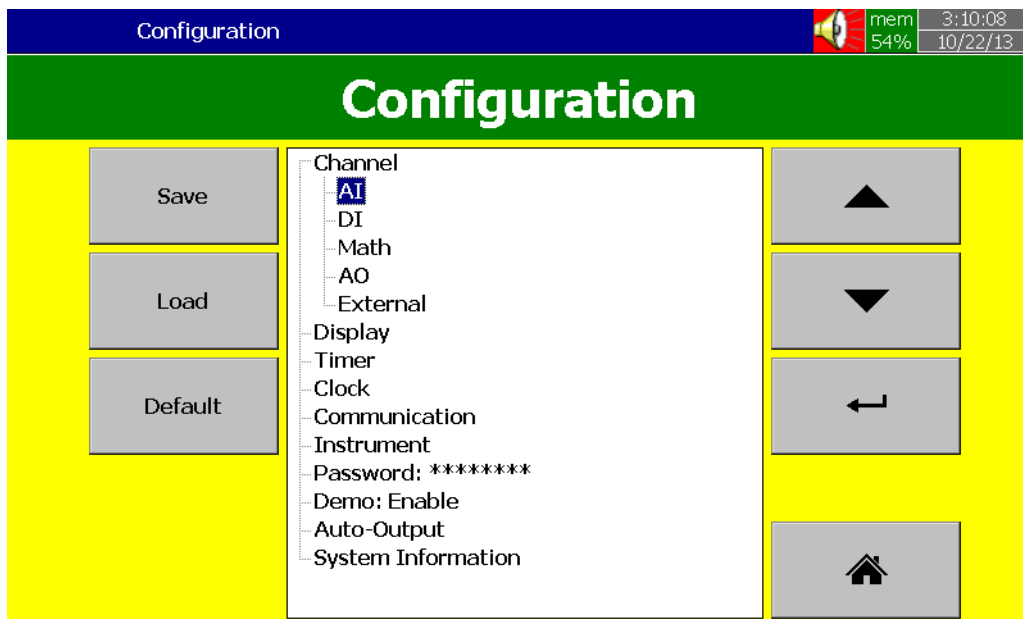
E:\Documents and Settings\Mahi>_
```

Fig: Response from the Recorder for the Ping instruction from PC

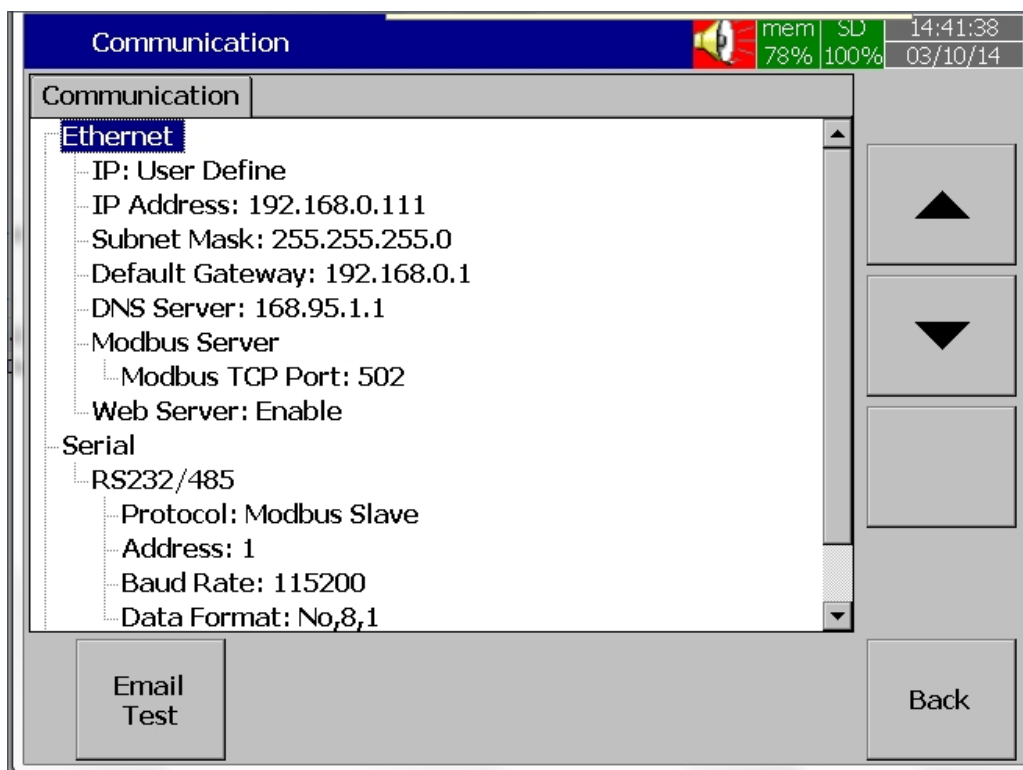
## 6.2 How to configure Web server Settings

For using Web server application in the WH series Recorder, Configure the Recorder for static IP address and Enable Web server.

## 6.2.1 How to Configure Static IP Address



In Configuration, select “Communication” and then WHess “Enter” soft key

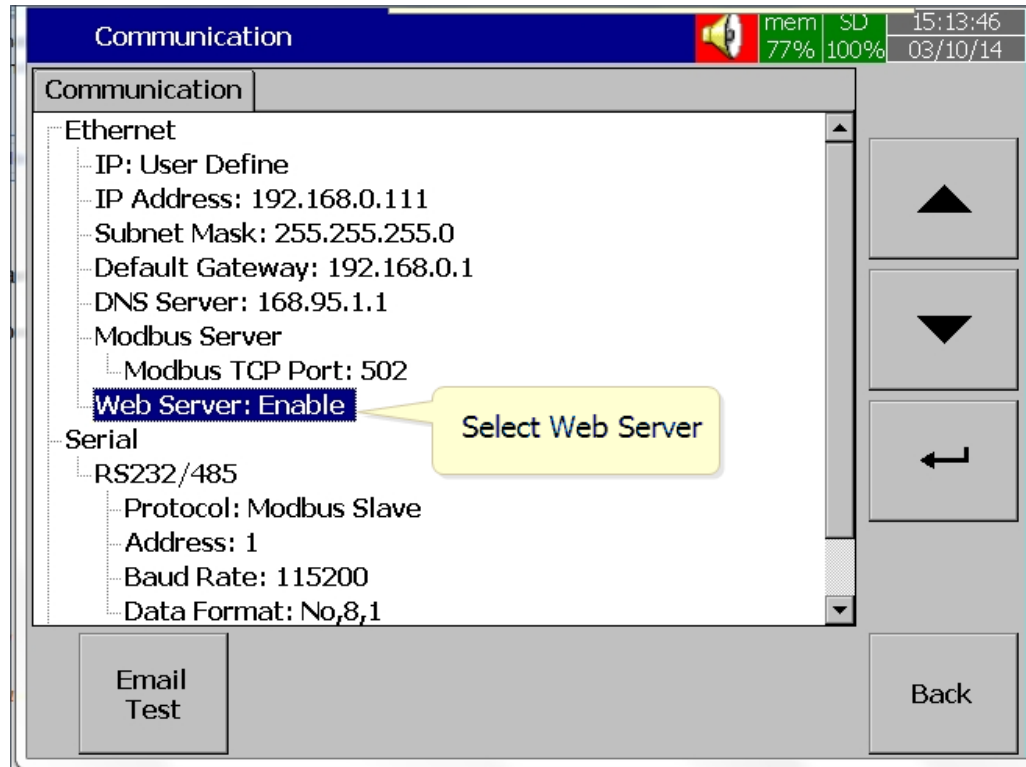


Select IP type = User Define.

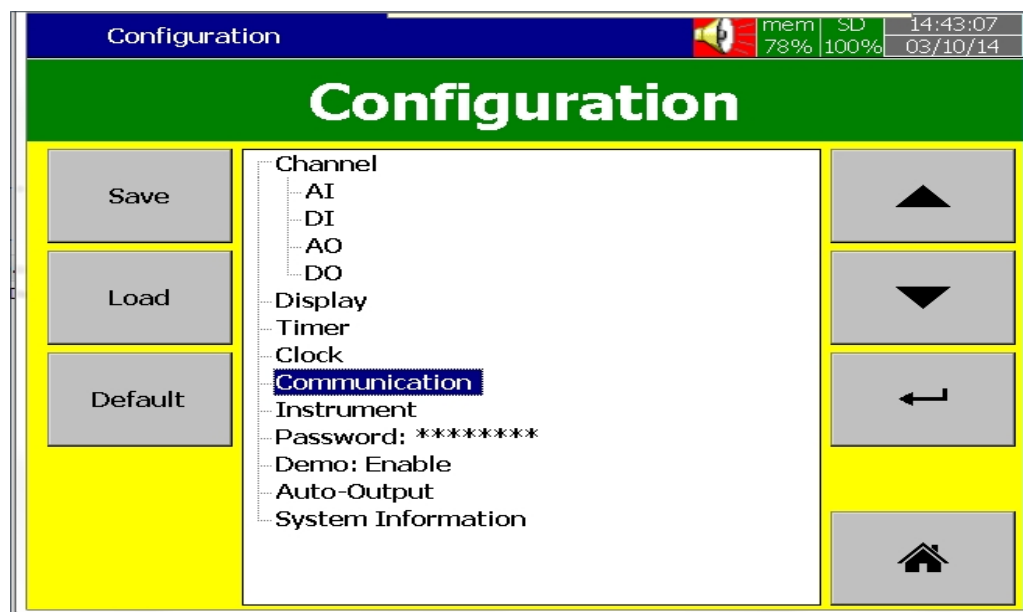
Enter the IP Address, Subnet Mask, Default Gateway, DNS Server Settings in the Ethernet Settings.

Note: Make sure to enter Global, Unique, static fix IP address received from Internet solution WHovider.

## 6.2.2 How to Enable Web Server



Select Web Server Menu in the Communication Menu.  
Enable the Web Server for using Web Server application in the Recorder.



After completing the above steps, WHess “BACK” key first then “Home” key to return to main menu. It will save the configuration settings in the Recorder.

Now the Recorder is ready for the Web Server Applications.

### 6.3 How to View Recorder Data in PC Via Webserver :

Connect Paperless Recorder to the Internet

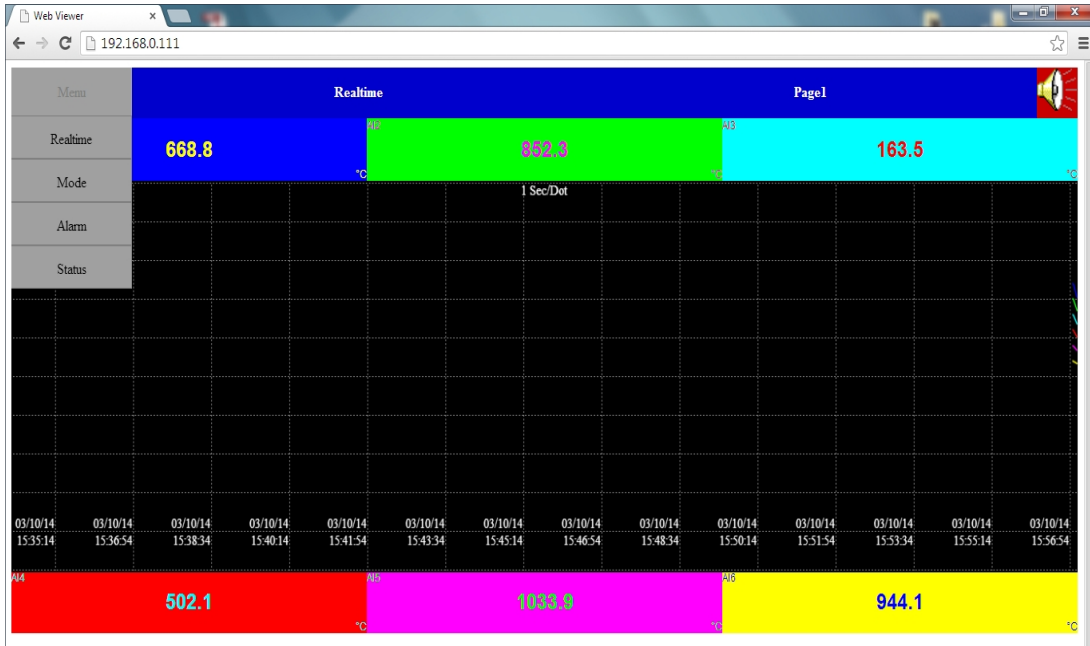
Open the browser ( IE 10 or Google chrome) in the PC



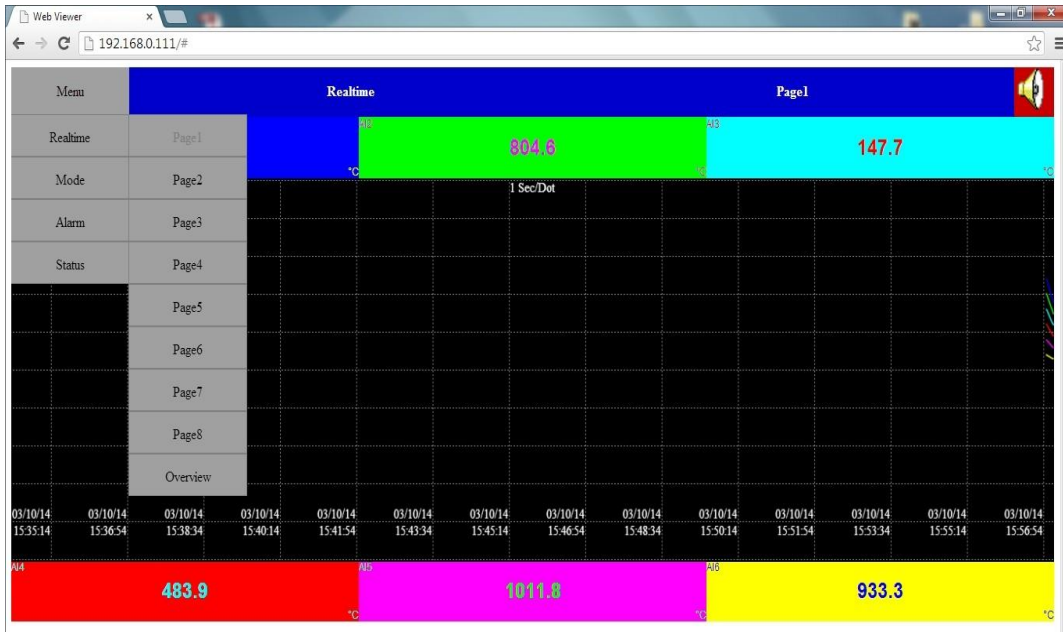
Enter the IP address of the Recorder in the address bar of the browser.

Format: `http://192.168.1.111`

Now you can see Paperless Recorder screens in browser as shown below



The display includes Real time values of all channels like AI,Math,Counters,Totalizers, Real time alarms, historical alarms, status of Digital Inputs, Digital Outputs, Analog Outputs, Counters, Totalizers etc..

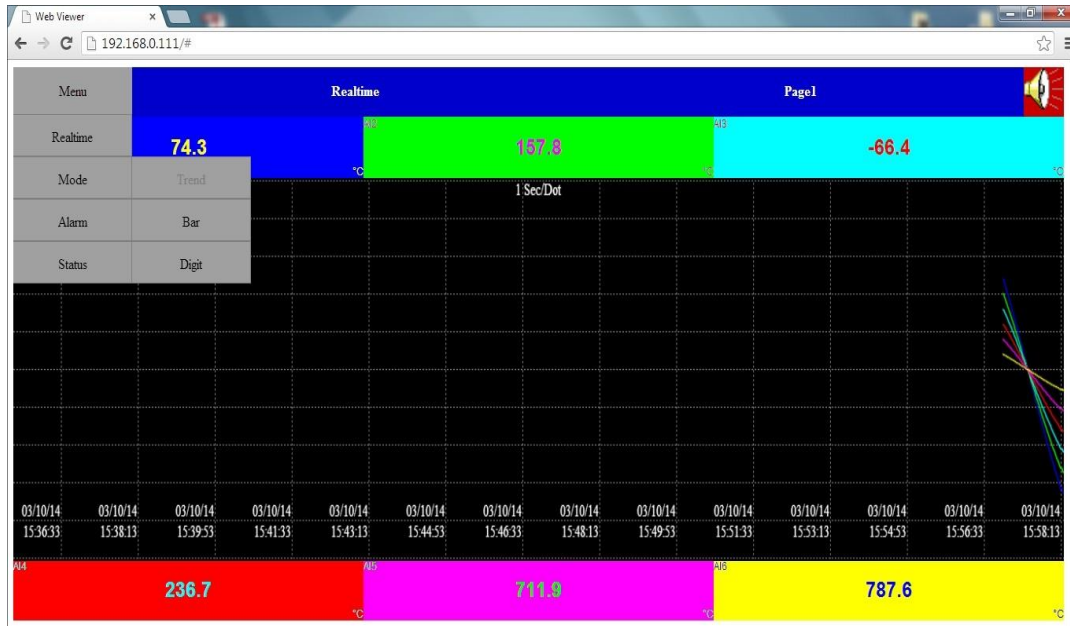


WHess Overview to view the summary of all datas in single screen

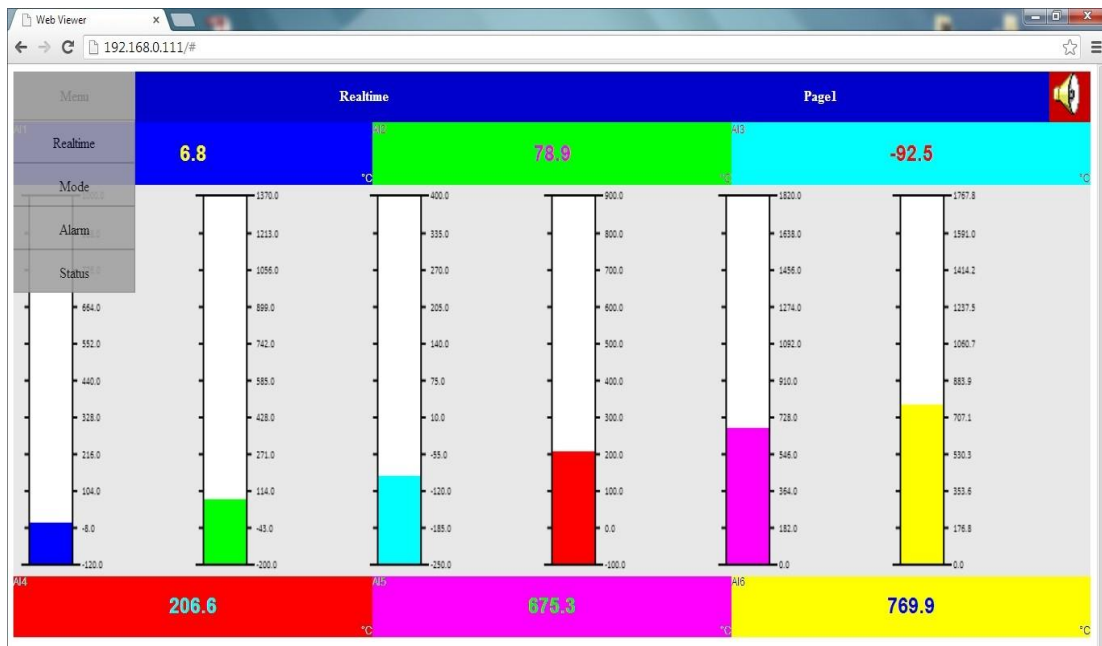


WHessing Mode You can view the datas in Bar Graph,Trend and Digital Values.

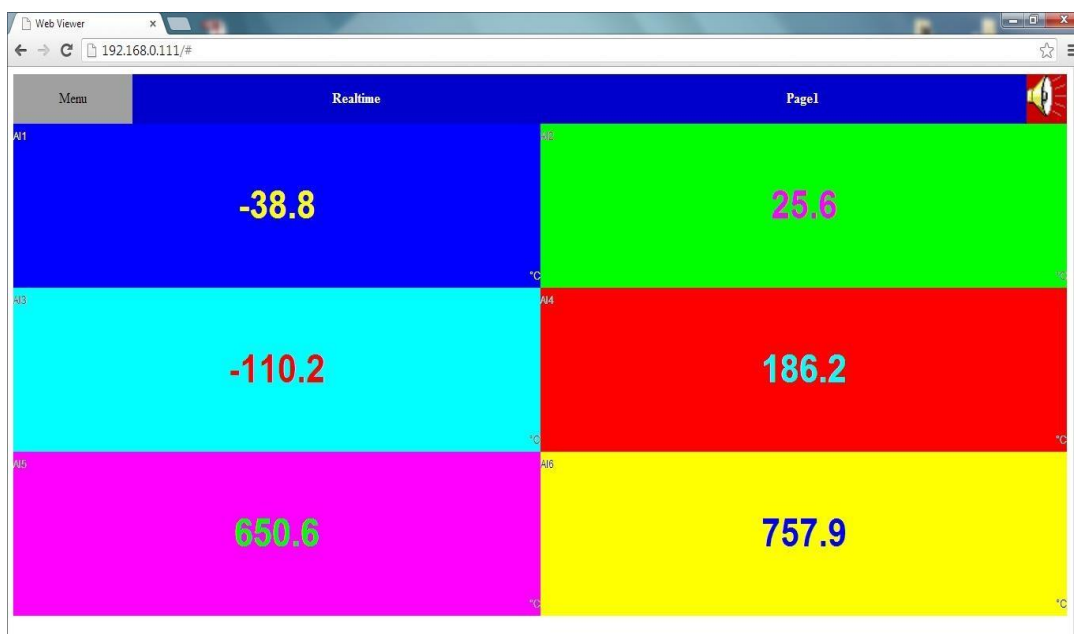
By WHessing Trend you can view the datas in trends.



By WHessing Bar You can view the datas in Bar Graph



By WHessing the Digit You can view the Datas in the digital format



WHessing Alarm You can view the List of Alarms with the details

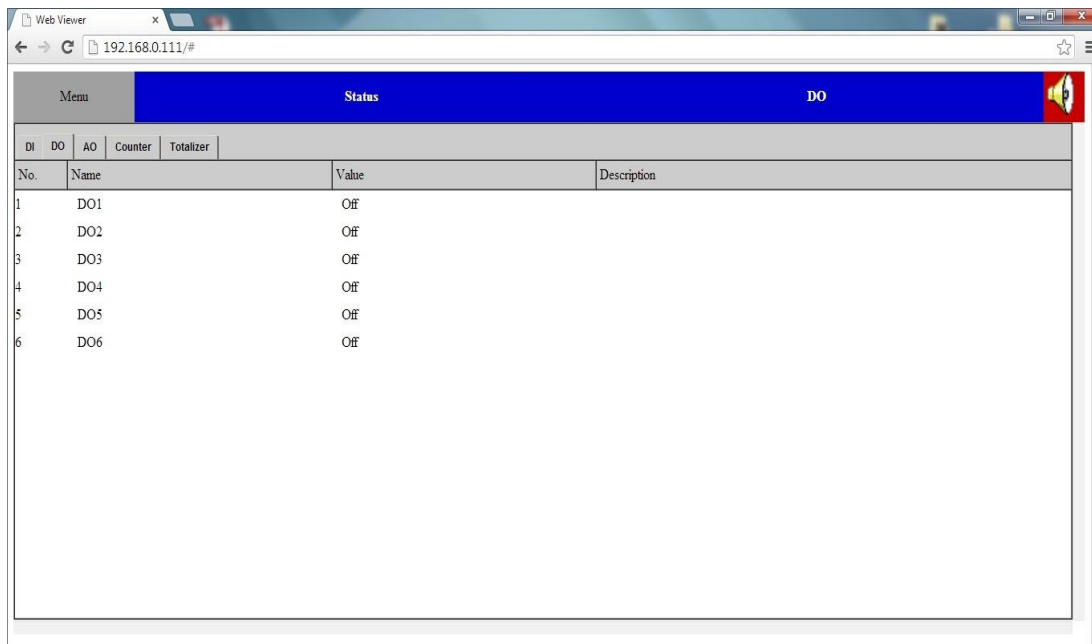
No.	Active Time	Acked	Type	Name	Value
1	02/05/14 16:11:12		LockAlarm	K17	18.10
2	02/05/14 16:11:12		LockAlarm	K17	18.10
3	02/05/14 16:11:12		LockAlarm	K18	20.40
4	02/05/14 16:11:12		RIAlarm	K119	1837.70
5	02/05/14 16:11:12		RIAlarm	K119	1837.70
6	02/05/14 16:11:12		RIAlarm	K121	2248.90
7	02/05/14 16:11:12		RIAlarm	K122	2248.90
8	02/05/14 16:11:12		RIAlarm	K123	551.90
9	02/05/14 16:11:09		RIAlarm	K113	80.80
10	02/05/14 16:11:09		RIAlarm	K115	19.10
11	02/05/14 16:11:09		RIAlarm	K117	88.90
12	02/05/14 16:11:09		LockAlarm	K115	11.70
13	02/05/14 16:11:03		RIAlarm	K111	778.30
14	02/05/14 16:11:07		RIAlarm	K114	80.10
15	02/05/14 16:11:07		LockAlarm	K117	19.86
16	02/05/14 16:11:03		RIAlarm	K12	1056.20
17	02/05/14 16:11:06		RIAlarm	K11	861.20
18	02/05/14 16:12:13		RIAlarm	K12	1176.40
19	02/05/14 16:12:13		RIAlarm	K13	270.90
20	02/05/14 16:13:24		LockAlarm	K119	217.90
21	02/05/14 16:13:33		LockAlarm	K120	220.60
22	02/05/14 16:13:37		LockAlarm	K113	87.80
23	02/05/14 16:13:44		RIAlarm	K17	1437.80
24	02/05/14 16:13:55		LockAlarm	K120	21.10
25	02/05/14 16:13:55		LockAlarm	K121	195.30
26	02/05/14 16:13:56		RIAlarm	K18	1942.20
27	02/05/14 16:13:59		RIAlarm	K17	1588.00
28	02/05/14 16:14:14		RIAlarm	K18	2152.80
29	02/05/14 16:14:14		RIAlarm	K11F	80.20
30	02/05/14 16:14:02		LockAlarm	K18	20.80

WHessing Status you can view the status of the Analog outputs, Digital Inputs, Digital Outputs, Counters and Totalizers.

By WHessing DI you can view the status of the Digital Inputs

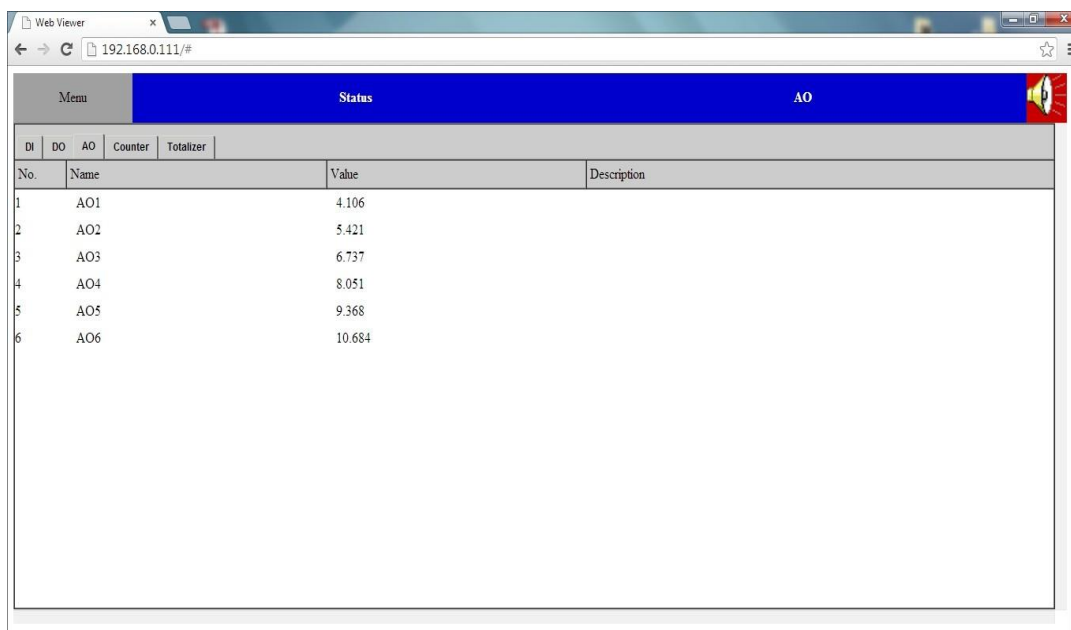
DI	DO	AO	Counter	Totalizer
No.	Name	Value	Description	
1	DI1	Hi		
2	DI2	3		
3	DI3	Hi		
4	DI4	3		
5	DI5	Hi		
6	DI6	3		

By WHessing DO you can view the status of the Digital outputs



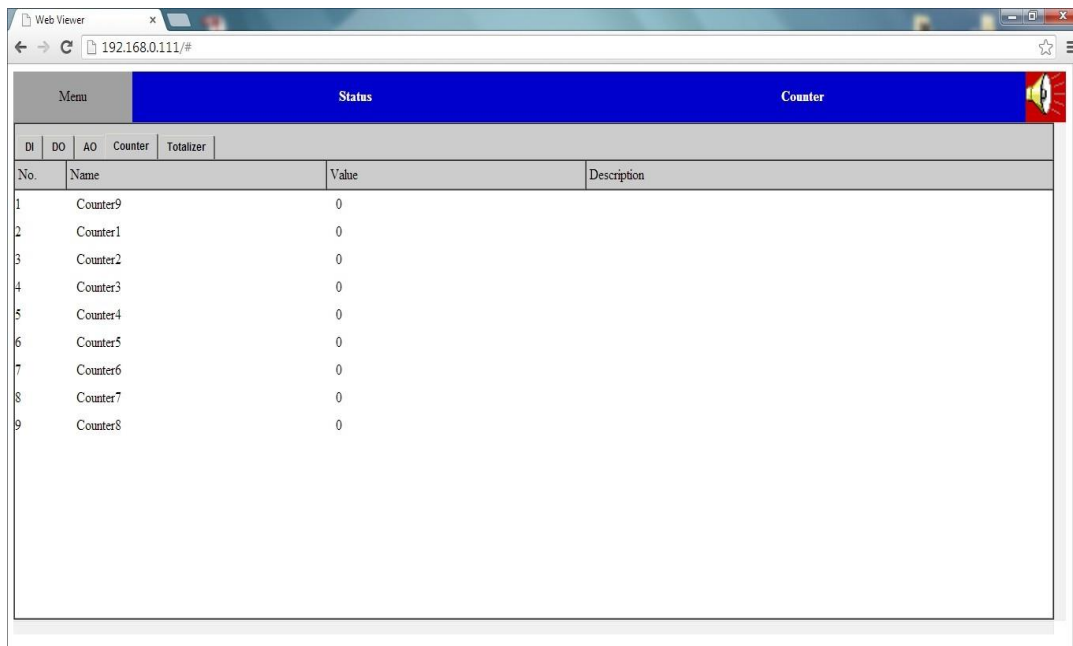
DI	DO	AO	Counter	Totalizer	
No.	Name		Value		Description
1	DO1		Off		
2	DO2		Off		
3	DO3		Off		
4	DO4		Off		
5	DO5		Off		
6	DO6		Off		

By WHessing AO you can view the status of the Analog Outputs



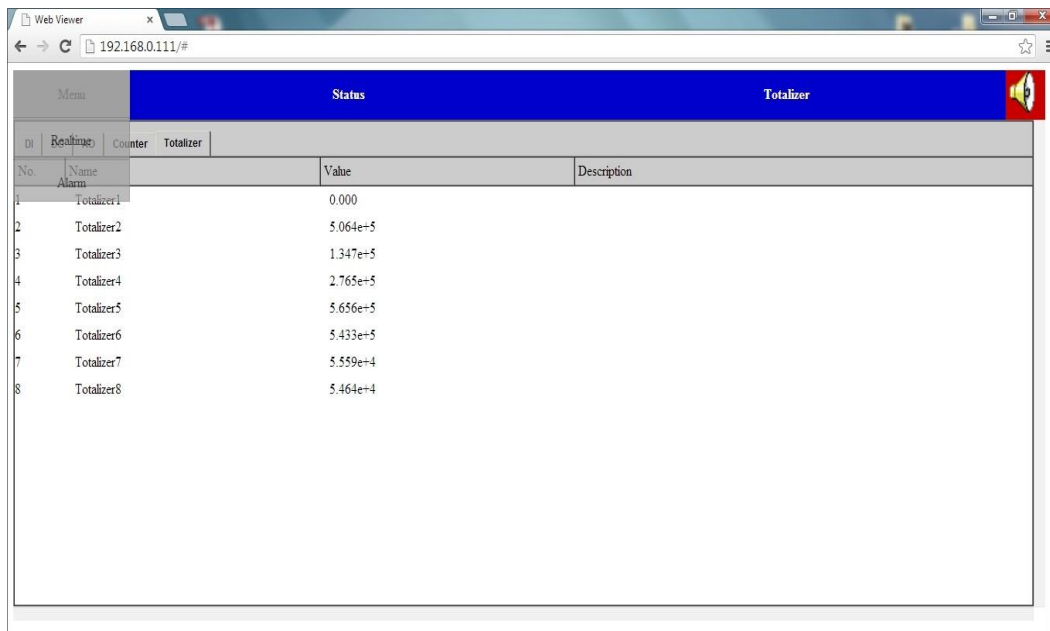
DI	DO	AO	Counter	Totalizer	
No.	Name		Value		Description
1	AO1		4.106		
2	AO2		5.421		
3	AO3		6.737		
4	AO4		8.051		
5	AO5		9.368		
6	AO6		10.684		

By WHessing Counters you can view the status of the counters



No.	Name	Value	Description
1	Counter9	0	
2	Counter1	0	
3	Counter2	0	
4	Counter3	0	
5	Counter4	0	
6	Counter5	0	
7	Counter6	0	
8	Counter7	0	
9	Counter8	0	

By WHessing Totalizers you can view the status of the totalizers.



No.	Name	Value	Description
1	Totalizer1	0.000	
2	Totalizer2	5.064e+5	
3	Totalizer3	1.347e+5	
4	Totalizer4	2.765e+5	
5	Totalizer5	5.656e+5	
6	Totalizer6	5.433e+5	
7	Totalizer7	5.559e+4	
8	Totalizer8	5.464e+4	